



# Application Note: SY21603

## High Efficiency H-Bridge Motor Driver IC

### General Description

The SY21603 is a dual H-bridge motor driver solution for toys, printers, and other mechatronic applications. The SY21603 operates with a power-supply voltage range from 2.5V to 16V, and 1.5A RMS maximum output current.

The device can drive two DC brush motors, a bipolar stepper motor, solenoids, or other inductive loads. The highly integrated H-bridge driver block consists of two H-bridges with internal logic control, gate drive, over current protection and charge pump circuit. Each H-bridge includes circuitry to regulate or limit the winding current.

The SY21603 provides internal shutdown functions with a fault output pin are provided for over current protection, short circuit protection, under voltage lockout and thermal shutdown. A low-power sleep mode is also provided. The device is packaged in two different types: a 16-pin TSSOP, a 16-pin QFN package.

### Features

- Dual H-bridge Motor Driver
- Maximum Drive Current of 1.5A RMS Current for Each H-bridge
- Power Supply Voltage Range from 2.5V to 16V
- PWM (IN/IN) Interface
- PWM Winding Current Regulation/Limit
- Internal OCP/SCP/UVL and thermal shutdown
- Multiple Packages Choice: TSSOP-16E/QFN4x4-16

### Applications

- POS Printers
- DSLR Lenses
- Video Security Cameras
- Toys
- Robotics
- Game Machines
- Office Automation Machines

### Ordering Information

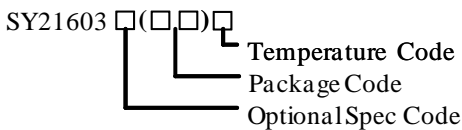

Ordering Number	Package type	Note
SY21603HFC	TSSOP-16E	
SY21603QIC	QFN4x4-16	

### Typical Applications

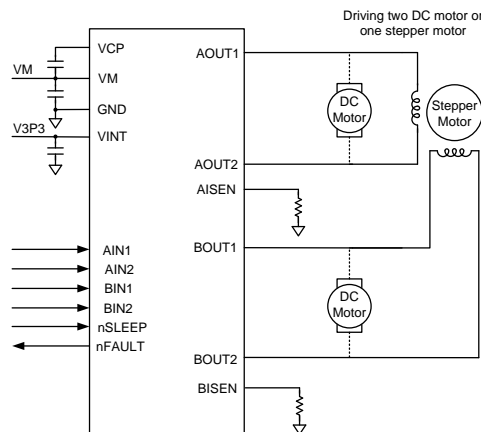
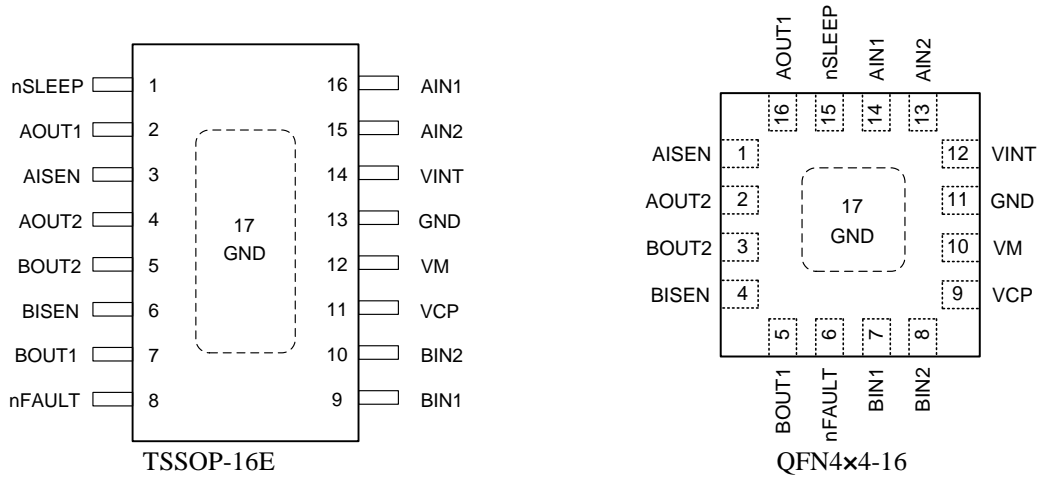

Figure1. Schematic Diagram

## Pinout (top view)



Part Number	Package type	Top Mark <sup>①</sup>
SY21603HFC	TSSOP-16E	AZRxyz
SY21603QIC	QFN4x4-16	BGSxyz

Note ①: x=year code, y=week code, z= lot number code.

Name	Number		Description
	TSSOP-16E	QFN4x4-16	
nSLEEP	1	15	Sleep mode pin. Logic low puts device in low-power sleep mode, this pin has a internal pull-down resistor
AOUT1	2	16	Bridge A output 1 pin. Connect this pin to motor winding.
AISEN	3	1	Bridge A current sense pin. Connect a resistor between this pin and GND for current control, or connect to GND if current control is not needed.
AOUT2	4	2	Bridge A output 2 pin. Connect this pin to motor winding.
BOUT2	5	3	Bridge B output 2 pin. Connect this pin to motor winding.
BISEN	6	4	Bridge B current sense pin. Connect a resistor between this pin and GND for current control, or connect to GND if current control is not needed
BOUT1	7	5	Bridge B output 1 pin. Connect this pin to motor winding.
nFAULT	8	6	Fault state output pin. Logic low if fault is detected.
BIN1	9	7	Bridge B input 1 pin. Control the state of bridge B, this pin has an internal pull-down resistor.
BIN2	10	8	Bridge B input 2 pin. Control the state of bridge B, this pin has an internal pull-down resistor
VCP	11	9	Internal charge pump voltage for high side gate driver. Connect a ceramic capacitor to VM.
VM	12	10	Motor power supply pin. Decouple this pin to GND pin with 10uF ceramic cap.
GND	13	11	Device ground pin.
VINT	14	12	Internal logic and driver supply. Connect this pin with a ceramic capacitor to GND.
AIN2	15	13	Bridge a input 2 pin. Control the state of bridge A, this pin has an internal pull-down resistor.
AIN1	16	14	Bridge A input 1 pin. Control the state of bridge A, this pin has an internal pull-down resistor.
GND	17	17	Ground pin for thermal dissipation.

## Block Diagram

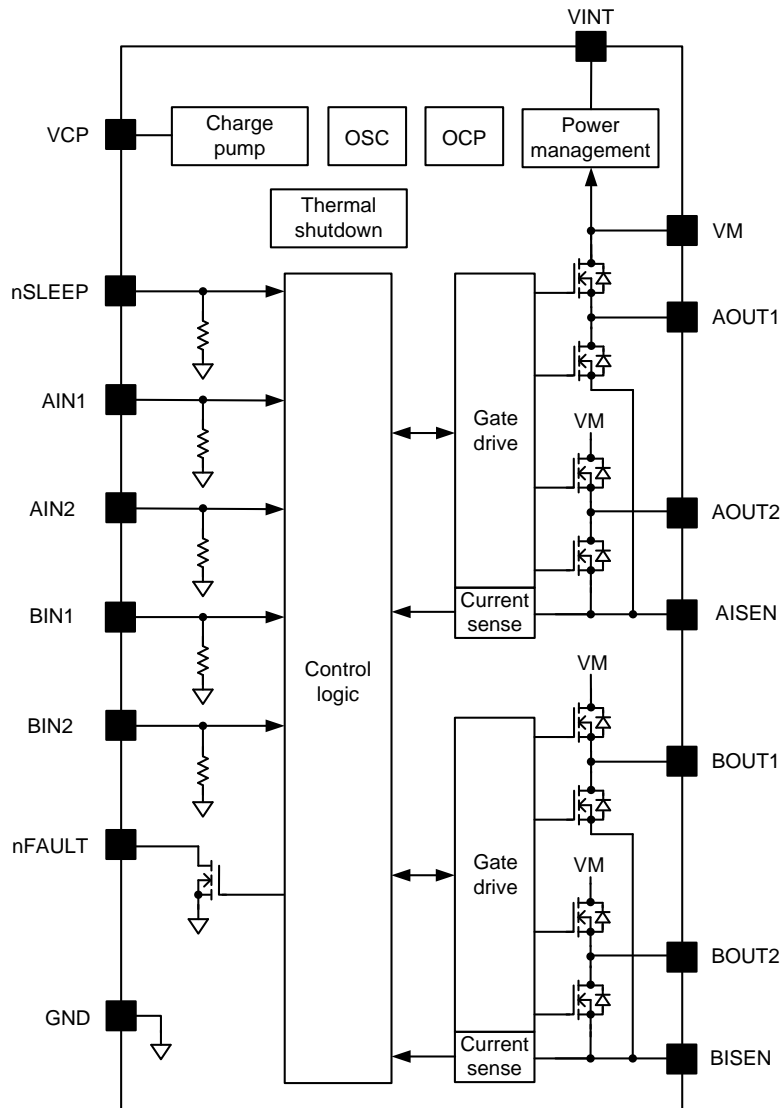

Figure2. Block Diagram



## Absolute Maximum Ratings (Note 1)

VM, OUT1, OUT2, nFAULT, nSLEEP	-----	16V
VCP	-----	VM+3.3V
xIN1, xIN2	-----	-0.3V to 6V
xISEN	-----	-0.3V to 0.5V
Junction Temperature (T <sub>J</sub> )	-----	-40 °C to +150 °C
Storage Temperature	-----	-65 °C to +150 °C
Package Thermal Resistance		
θ <sub>JA</sub> (Note 2), TSSOP-16E/QFN4x4-16	-----	41/38 °C/W
θ <sub>JC_TOP</sub> , TSSOP-16E/QFN4x4-16	-----	33/35 °C/W

## Recommended Operating Conditions

VM, nSLEEP	-----	2.5V to 12V
xIN1, xIN2	-----	-0.1V to 5V
H-Bridge Output RMS Current (Note3) (Package TSSOP-16E/QFN4x4-16)	-----	0A to 1.5A
Junction Temperature Range	-----	-40 °C to 125 °C
Ambient Temperature Range	-----	-40 °C to 85 °C

## Electrical Characteristics

(T<sub>A</sub> = 25 °C, VM=5V, unless otherwise specified)

Parameter	Symbol	Test Conditions	Min	Typ	Max	Unit
<b>Power Supplies</b>						
VM Operating Supply Current	I <sub>VM</sub>	VM=5V, xIN=0V, xIN2=0V		0.65	1.2	mA
VM Sleep Mode Current	I <sub>VMS</sub>	nSLEEP=0V, VM=5V		1.8	2.5	μA
VM UVL Voltage	V <sub>UVLO_RISE</sub>	VM Rising		2.0		V
	V <sub>UVLO_FALL</sub>	VM Falling		1.9		V
VINT	V <sub>INT</sub>	nSLEEP=3V, VM=5V	3	3.3		V
<b>Logic Level Input</b>						
Input Low Voltage	V <sub>IL</sub>	nSLEEP			0.4	V
		All other pins			0.7	
Input High Voltage	V <sub>IH</sub>	nSLEEP	2.5			V
		All other pins	2.2			
Input Low Current	I <sub>IL</sub>	V <sub>IN</sub> =0V			1	μA
Input High Current	I <sub>IH</sub>	V <sub>IN</sub> =3.3V, nSLEEP		5.3	12	μA
		V <sub>IN</sub> =3.3V, all except nSLEEP		18	30	
Input Deglitch Time	t <sub>DEG</sub>	(Note 4)		450		ns
<b>nFAULT Output (Open-Drain Output)</b>						
Output Low Voltage	V <sub>OL</sub>	I <sub>O</sub> =5mA			0.2	V
Output High Leakage Current	I <sub>OH</sub>	V <sub>O</sub> =3.3V			1	μA
<b>H-Bridge MOSFETs</b>						
High Side MOSFETs On Resistance	R <sub>dson</sub>	V <sub>M</sub> =5V, I <sub>O</sub> =500mA, T <sub>J</sub> =25 °C		260		mΩ
Low Side MOSFETs On Resistance		V <sub>M</sub> =5V, I <sub>O</sub> =500mA, T <sub>J</sub> =25 °C		220		
Off-State Leakage Current	I <sub>OFF</sub>	V <sub>M</sub> =5V, V <sub>OUT</sub> =0V, T <sub>J</sub> =25 °C			±1	μA
<b>Motor Driver</b>						
Current Control PWM Frequency	f <sub>PWM</sub>	Internal PWM Frequency		50		kHz
Rise Time	t <sub>R</sub>	V <sub>M</sub> =5V, 16Ω to GND, 10% to 90% V <sub>M</sub> , Note4		60		ns
Fall Time	t <sub>F</sub>			50		ns
Propagation Delay IN <sub>x</sub> to OUT <sub>x</sub>	t <sub>PROP</sub>	V <sub>M</sub> =5V, Note4		0.35		μs
Dead Time	t <sub>DEAD</sub>	V <sub>M</sub> =5V, Note4		100		ns

<b>Protection</b>						
Output Over Current Limit	$I_{OCP}$		1.8	3		A
Over Current Retry Time	$t_{OCPR}$			1.5		ms
OCP Deglitch Time	$t_{DEG}$	Note 4		180		ns
Thermal Shutdown Temperature	$T_{SD}$			160		°C
Thermal Shutdown hysteresis	$T_{HYS}$			20		°C
<b>Current Control</b>						
xISEN Trip Voltage	$V_{TRIP}$		160	200	240	mV
Current Sense Blanking Time	$t_{BLANK}$			3.0		µs

**Note 1:** Stresses beyond the “Absolute Maximum Ratings” may cause permanent damage to the device. These are for stress ratings only. Functional operation of the device at these or any other conditions beyond those indicated in the operational sections of the specifications is not implied. Exposure to absolute maximum rating conditions for extended periods may affect device reliability.

**Note 2:**  $\theta_{JA}$  is measured in the natural convection at  $T_A = 25\text{ °C}$  on a low effective single layer thermal conductivity test board of JEDEC 51-3 thermal measurement standard.

**Note 3:** Power dissipation and thermal limits must be observed.

**Note 4:** Guaranteed by design.

## Typical performance characteristics

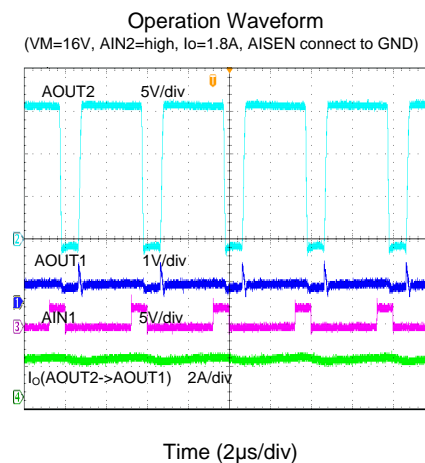
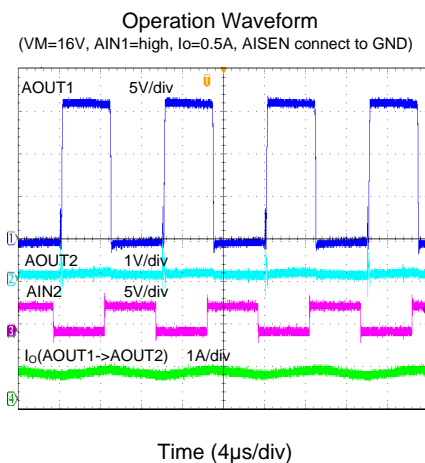
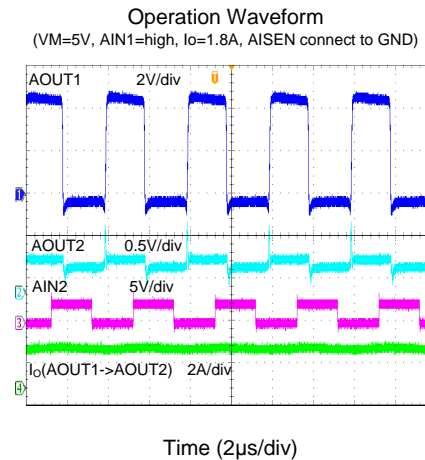
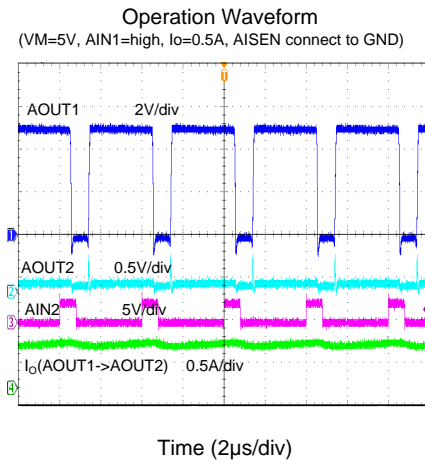
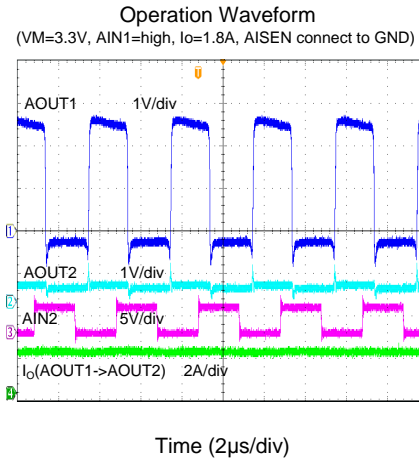
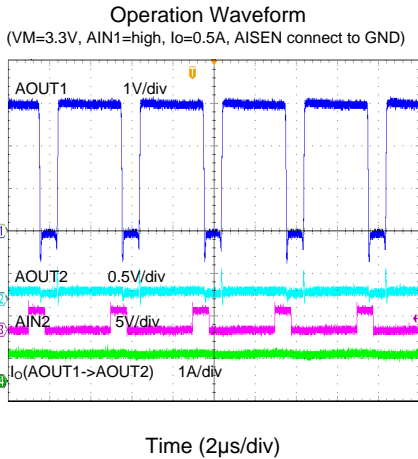

### Operation Waveform

(VM=5V, AIN2=AIN1, I<sub>o</sub>=0.5A, AISEN connect to GND)

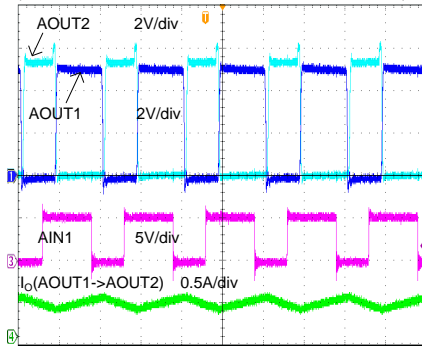

Time (2μs/div)

### Operation Waveform

(VM=5V, AIN2=0, I<sub>o</sub>=0.5A, AISEN connect to GND)

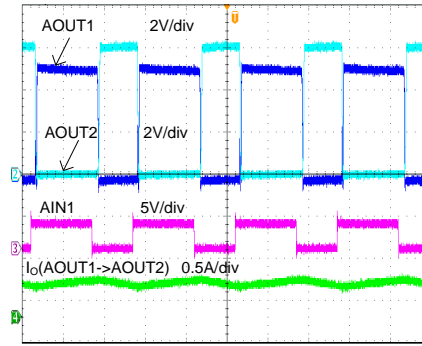

Time (4μs/div)

### Current Regulation

(VM=5V, AIN1=1, AIN2=0, R<sub>sense</sub>=0.35Ω)

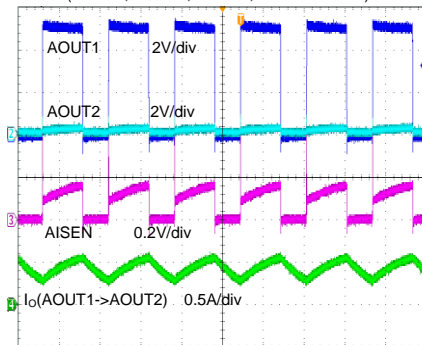

Time (10μs/div)

## Functional Description

### PWM Motor Drivers

SY21603 contains two identical H-bridge motor drivers with current-control PWM circuitry. A block diagram of the circuitry is shown below:

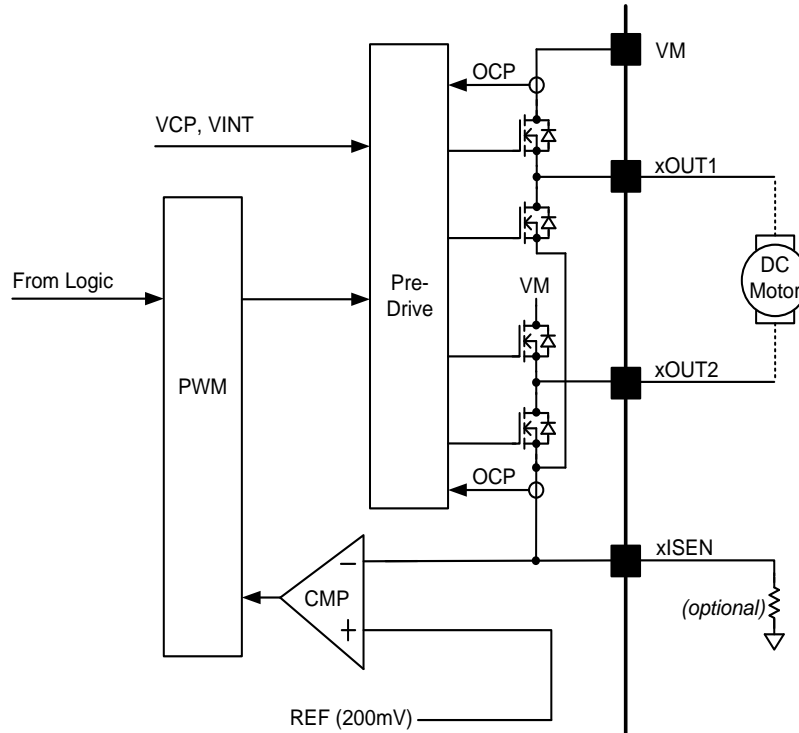

Figure3. Motor Control Circuitry

### H-Bridge Driving Control

The Bridge is controlled by a PWM input interface, also called IN/IN interface. The following table shows the control logic of the device:

Table 1 H-Bridge Logic

xIN1	xIN2	xOUT1	xOUT2	Function
0	0	Z	Z	Coast/Fast Decay
0	1	L	H	Reverse
1	0	H	L	Forward
1	1	L	L	Brake/Slow Decay

The inputs can also be used for PWM control of the motor speed. When controlling a winding with PWM and the drive current is interrupted, the inductive nature of the motor requires that the current must continue to flow. This is called recirculation current. To handle this recirculation current, the H-bridge can operate in two different states, fast decay or slow decay. In fast decay mode, the H-bridge is disabled and recirculation current flows through the body diodes; in slow decay, the motor winding is shorted.

For PWM using fast decay, the PWM signal is applied to one xIN pin while the other is held low; to use slow decay, one xIN pin is held high.



Table 2 PWM Control of Motor Speed

xIN1	xIN2	Function
PWM	0	Forward PWM, Fast Decay
1	PWM	Forward PWM, Slow Decay
0	PWM	Reverse PWM, Fast Decay
PWM	1	Reverse PWM, Slow Decay

Figure 4 shows the current paths in different drive and decay modes.

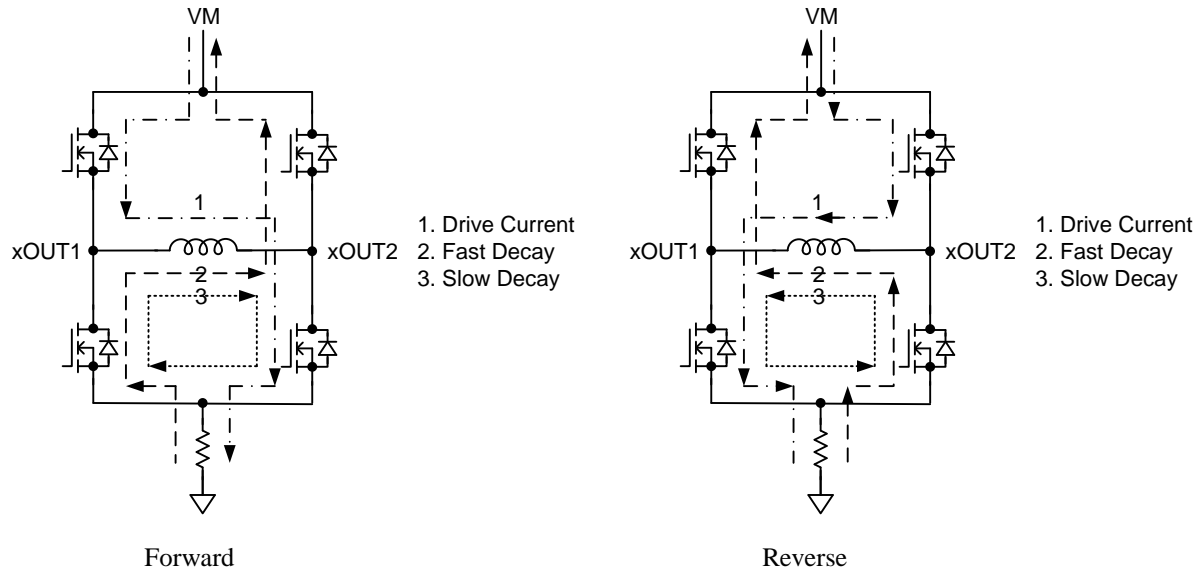

Figure 4. Decay Mode

## Current Control

The current through the motor windings may be limited, or controlled, by a fixed-frequency PWM current regulation, or current chopping. For DC motors, current control is used for limiting the start-up and stalling current of the motor. For stepper motors, current control is used frequently at all times.

When an H-bridge is enabled, current rises through the winding at a rate dependent on the DC voltage and inductance of the winding. If the current reaches the current chopping threshold, the bridge will disable the current until the beginning of the next PWM cycle. Note that immediately after the current is enabled, the voltage on the xISEN pin is ignored for a fixed period of time before enabling the current sense circuitry. This blanking time is fixed at about 3.1μs. This blanking time also sets the minimum on time of the PWM when operating in current chopping mode.

The PWM chopping current is set by a comparator which compares the voltage across a current sense resistor connected to the xISEN pins with a reference voltage. The reference voltage is fixed at 200 mV.

The chopping current is calculated in Equation 1.

$$I_{CHOP} = \frac{200mV}{R_{SENSE}} \quad (1)$$

Example:

If a 1Ω sense resistor is used, the chopping current will be 200 mV/1 Ω = 200 mA.

Once the chopping current threshold is reached, the H-bridge will switch to slow decay mode. Winding current is re-circulated by enabling both of the low-side FETs in the bridge. This state is held until the beginning of the next fixed-frequency PWM cycle.

Note that if current control is not needed, the xISEN pins should be connected directly to ground.

## Sleep Mode

Driving nSLEEP low will put the device into a low power sleep state. In this state, the H-bridges are disabled, the gate drive charge pump is stopped, all internal logic is reset, and all internal clocks are stopped. All inputs are ignored until nSLEEP returns inactive high. When returning from sleep mode, some time needs to pass before the motor driver becomes fully operational. To make the board design simple, the nSLEEP can be pulled up to the supply (VM).

## Over Current Protection (OCP)

An analog current limit circuit on each FET limits the current through the FET by limiting the gate drive. If this analog current limit persists for longer than the OCP deglitch time, all FETs in the H-bridge will be disabled and the nFAULT pin will be driven low. The driver will be re-enabled after the OCP retry period ( $t_{OCP}$ ) has passed. nFAULT becomes high again at this time. If the fault condition is still present, the cycle repeats. If the fault is no longer present, normal operation resumes. Please note that only the H-bridge in which the OCP is detected will be disabled while the other bridge will function normally.

Over current conditions are detected independently on both high and low side devices; i.e., a short to ground, supply, or across the motor winding will all result in an over current shutdown. Over current protection does not use the current sense circuitry for PWM current control, it works even without presence of the xISEN resistors.

## Thermal Shutdown (TSD)

If the die temperature exceeds safe limits, all MOSFETs in the H-bridge will be disabled. Once the die temperature has fallen to a safe level, operation automatically resumes.

## Under Voltage Lockout (UVLO)

If at any time the voltage on the VM pin falls below the under voltage lockout threshold voltage, all circuitry in the device will be disabled, and all internal logic will be reset. Operation will resume when VM rises above the UVLO threshold. nFAULT is driven low in the event of an under voltage condition.

## Maximum Output Current

In actual operation, the maximum output current achievable with a motor driver is a function of die temperature. This in turn is greatly affected by ambient temperature and PCB design. Basically, the maximum motor current will be the amount of current that results in a power dissipation level that, along with the thermal resistance of the package and PCB, keeps the die at a low enough temperature to stay out of thermal shutdown.

The dissipation ratings given in the datasheet can be used as a guide to calculate the approximate maximum power dissipation that can be expected to be possible without entering thermal shutdown for several different PCB constructions. However, for accurate data, the actual PCB design must be analyzed via measurement or thermal simulation.

**TSSOP16E Package Outline Drawing**

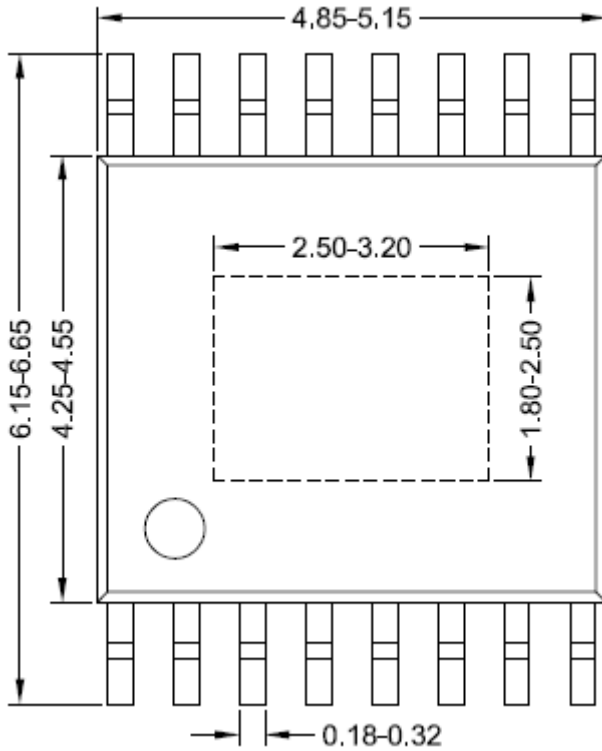

**Top view**

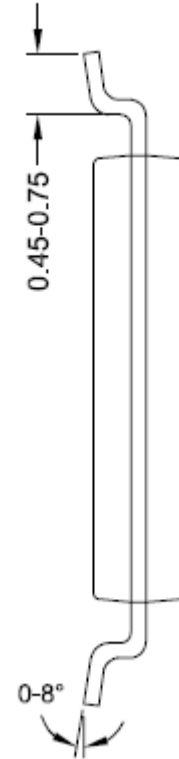

**Side view A**

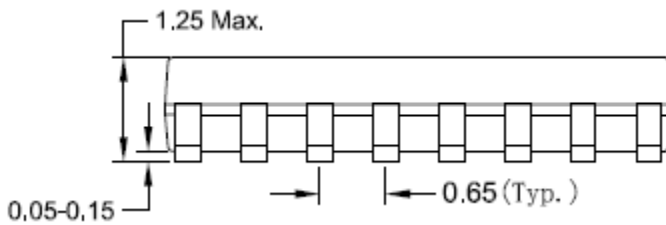

**Side view B**

**Notes: All dimension in millimeter and exclude mold flash & metal burr.**

**QFN4×4-16 Package Outline Drawing**

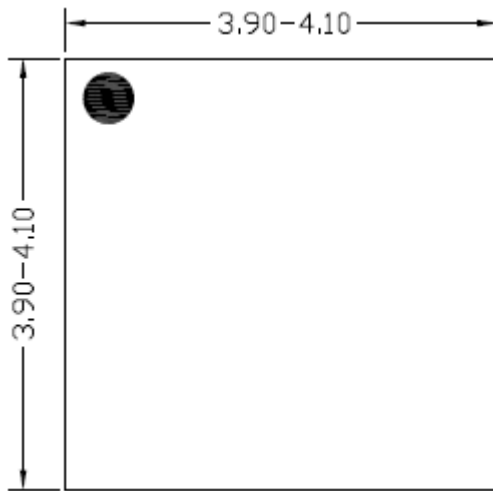

**Top View**



**Side View**

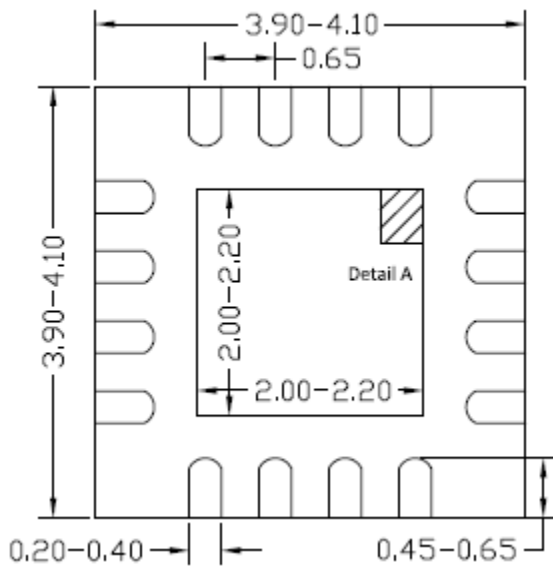

**Bottom View**

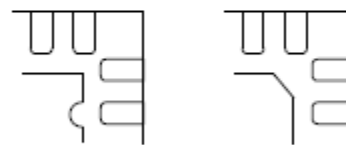

Detail A  
Pin1 Identifier: two options

**Notes:** All dimension in millimeter and exclude mold flash & metal burr.

## Taping & Reel Specification

### 1. TSSOP16E Taping orientation

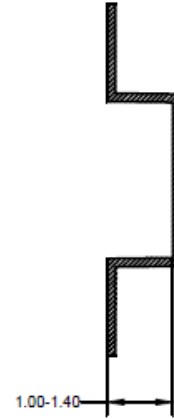
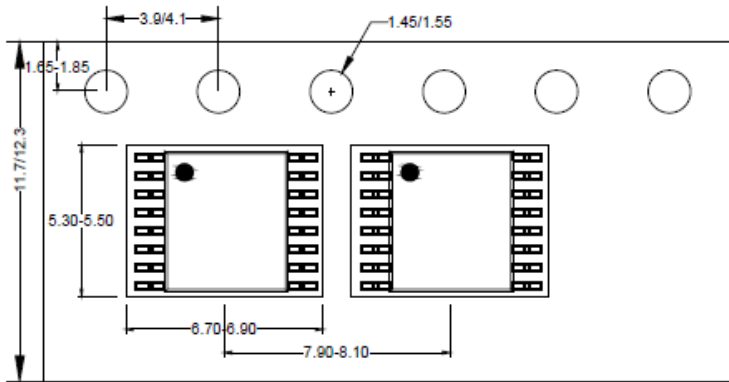

Feeding direction →

### 2. QFN4x4 Taping orientation

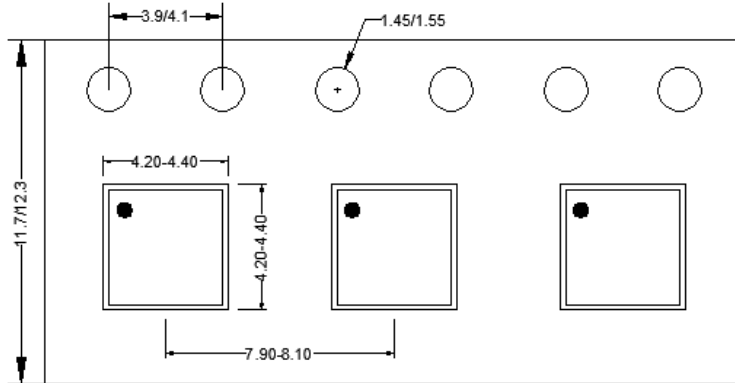

Feeding direction →

**3. Carrier Tape & Reel specification for packages**

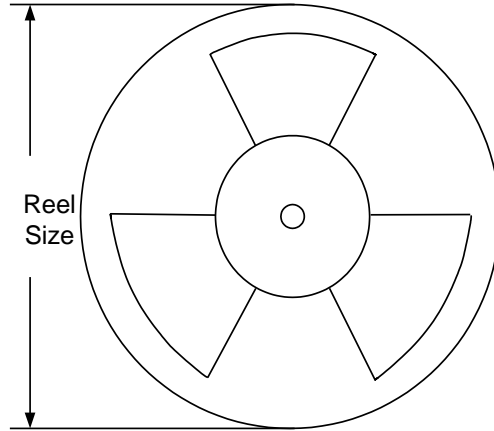

Package types	Tape width (mm)	Pocket pitch(mm)	Reel size (Inch)	Trailer * length(mm)	Leader * length (mm)	Qty per reel (pcs)
TSSOP16E	12	8	13"	400	400	3000
QFN4x4	12	8	13"	400	400	5000

**4. Others: NA**



## IMPORTANT NOTICE

1. **Right to make changes.** Silergy and its subsidiaries (hereafter Silergy) reserve the right to change any information published in this document, including but not limited to circuitry, specification and/or product design, manufacturing or descriptions, at any time and without notice. This document supersedes and replaces all information supplied prior to the publication hereof. Buyers should obtain the latest relevant information before placing orders and should verify that such information is current and complete. All semiconductor products are sold subject to Silergy's standard terms and conditions of sale.
2. **Applications.** Application examples that are described herein for any of these products are for illustrative purposes only. Silergy makes no representation or warranty that such applications will be suitable for the specified use without further testing or modification. Buyers are responsible for the design and operation of their applications and products using Silergy products. Silergy or its subsidiaries assume no liability for any application assistance or designs of customer products. It is customer's sole responsibility to determine whether the Silergy product is suitable and fit for the customer's applications and products planned. To minimize the risks associated with customer's products and applications, customer should provide adequate design and operating safeguards. Customer represents and agrees that it has all the necessary expertise to create and implement safeguards which anticipate dangerous consequences of failures, monitor failures and their consequences, lessen the likelihood of failures that might cause harm and take appropriate remedial actions. Silergy assumes no liability related to any default, damage, costs or problem in the customer's applications or products, or the application or use by customer's third-party buyers. Customer will fully indemnify Silergy, its subsidiaries, and their representatives against any damages arising out of the use of any Silergy components in safety-critical applications. It is also buyers' sole responsibility to warrant and guarantee that any intellectual property rights of a third party are not infringed upon when integrating Silergy products into any application. Silergy assumes no responsibility for any said applications or for any use of any circuitry other than circuitry entirely embodied in a Silergy product.
3. **Limited warranty and liability.** Information furnished by Silergy in this document is believed to be accurate and reliable. However, Silergy makes no representation or warranty, expressed or implied, as to the accuracy or completeness of such information and shall have no liability for the consequences of use of such information. In no event shall Silergy be liable for any indirect, incidental, punitive, special or consequential damages, including but not limited to lost profits, lost savings, business interruption, costs related to the removal or replacement of any products or rework charges, whether or not such damages are based on tort or negligence, warranty, breach of contract or any other legal theory. Notwithstanding any damages that customer might incur for any reason whatsoever, Silergy' aggregate and cumulative liability towards customer for the products described herein shall be limited in accordance with the Standard Terms and Conditions of Sale of Silergy.
4. **Suitability for use.** Customer acknowledges and agrees that it is solely responsible for compliance with all legal, regulatory and safety-related requirements concerning its products, and any use of Silergy components in its applications, notwithstanding any applications-related information or support that may be provided by Silergy. Silergy products are not designed, authorized or warranted to be suitable for use in life support, life-critical or safety-critical systems or equipment, nor in applications where failure or malfunction of an Silergy product can reasonably be expected to result in personal injury, death or severe property or environmental damage. Silergy assumes no liability for inclusion and/or use of Silergy products in such equipment or applications and therefore such inclusion and/or use is at the customer's own risk.
5. **Terms and conditions of commercial sale.** Silergy products are sold subject to the standard terms and conditions of commercial sale, as published at <http://www.silergy.com/stdterms>, unless otherwise agreed in a valid written individual agreement specifically agreed to in writing by an authorized officer of Silergy. In case an individual agreement is concluded only the terms and conditions of the respective agreement shall apply. Silergy hereby expressly objects to and denies the application of any customer's general terms and conditions with regard to the purchase of Silergy products by the customer.
6. **No offer to sell or license.** Nothing in this document may be interpreted or construed as an offer to sell products that is open for acceptance or the grant, conveyance or implication of any license under any copyrights, patents or other industrial or intellectual property rights. Silergy makes no representation or warranty that any license, either express or implied, is granted under any patent right, copyright, mask work right, or other intellectual property right. Information published by Silergy regarding third-party products or services does not constitute a license to use such products or services or a warranty or endorsement thereof. Use of such information may require a license from a third party under the patents or other intellectual property of the third party, or a license from Silergy under the patents or other intellectual property of Silergy.

For more information, please visit: [www.silergy.com](http://www.silergy.com)

© 2018 Silergy Corp.

All Rights Reserved.