



SY20752B1

2A Single-Cell High Efficiency Switching Charger with Adaptive Input Current Limit

General Description

SY20752B1 is a 4.0-23V input, 2A single-cell synchronous Buck Li-ion battery charger, suitable for portable applications. VSET pin is convenient for different cell voltage. The integrated 800 kHz synchronous Buck regulator consists of 25V rating FETs with extremely low on resistance to achieve high charge efficiency and simple peripheral circuit design.

Ordering Information

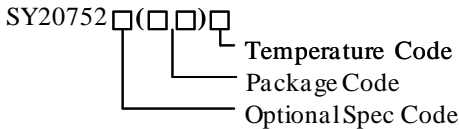

Ordering Number	Package type	Note
SY20752B1FCC	SO8E	

Features

- Wide Input Voltage Range: 4.0V to 23V
- High Efficiency Synchronous Buck Regulator with Fixed 800kHz Switching Frequency
- Trickle Current / Constant Current / Constant Voltage Charge Mode
- Adaptive Input Current Limit
- Programmable Charging Timeout
- 4.4V and 4.1V Selectable Cell Voltage
- Programmable (2A Max) Constant Charge Current
- Input Voltage UVLO and Battery OVP
- Over Temperature Protection
- Output Short Circuit Protection
- Charge Status Indication
- Normal Synchronous Buck Operation When the Battery is Removed
- Compact Package SO8E

Applications

- Cellular Telephones
- PDA, MP3 Players, MP4 Players
- Digital Cameras
- Bluetooth Applications
- PSP Game Players, NDS Game Players
- Notebook

Typical Applications

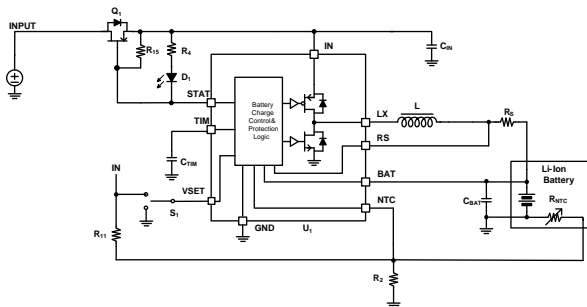

Figure 1. Schematic Diagram

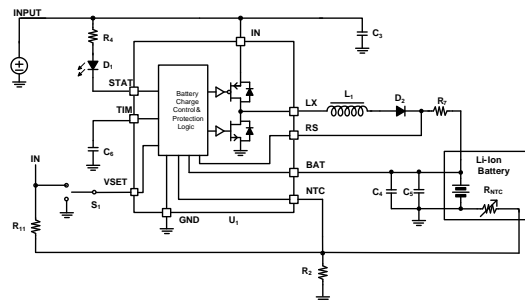
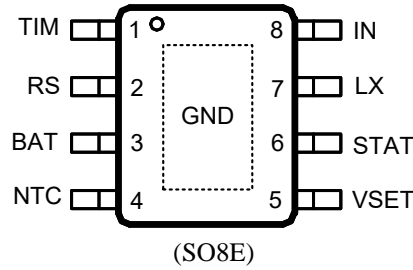

Figure 2. Typical Application Schematic with Diode

Pinout (Top View)



Top Mark: BQPxyz (device code: **BQP**, *x=year code*, *y=week code*, *z=lot number code*)

Pin Name	Pin Number	Pin Description
TIM	1	Charge time limit pin. Connect this pin with a capacitor to ground. The internal current source charges the capacitor for TC mode and CC mode's charge time limit. TC charge time limit is about 1/9 of the CC charge time.
RS	2	Charge current program pin. Connect a current sense resistor from RS pin to BAT pin. The average charge current is detected for both TC mode and CC mode.
BAT	3	Battery positive pin.
NTC	4	Thermal protection pin. UTP threshold is about 75% of V_{IN} and OTP threshold is about 30% of V_{IN} . Pulling it up to V_{IN} can disable charge logic and makes the IC operate as a normal Buck regulator. Pulling it down to ground can shut down the IC.
VSET	5	VSET is pulled down internally. Open or pull down it for 4.1V cell voltage, pull it up for 4.4V cell voltage.
STAT	6	Charge status indication pin. It is an open drain output pin and can be used to turn on a LED to indicate the charge in process. When the charge is done, the LED will be off.
LX	7	Switch node pin. This pin connects the drains of the integrated main and synchronous power MOSFET switches. Connect it to the external inductor.
IN	8	Positive power supply input pin. V_{IN} ranges from 4V to 23V for normal operation. It has UVLO function and must be 120mV greater than the battery voltage to enable normal operation.
GND	Exposed pad	Ground pin.



SY20752B1

Absolute Maximum Ratings (Note 1)

VSET, NTC, STAT	-0.5~32V
IN, BAT, LX	-0.5~25V
TIM	-0.5~3.6V
RS	BAT-0.3V to BAT+0.3V
LX Pin Continuous Current	2.5A
Power Dissipation, P _D @ T _A = 25°C, SO8E	3.3W
Package Thermal Resistance	
θ_{JA}	30°C/W
θ_{JC}	20°C/W
Junction Temperature Range	-40°C to 150°C
Lead Temperature (Soldering, 10 sec)	260°C
Storage Temperature Range	-65°C to 125°C
ESD Susceptibility (Note 2)	
HBM (Human Body Mode)	2kV
MM (Machine Mode)	200V

Recommended Operating Conditions

VSET, NTC, STAT	-0.3- 30V
IN, BAT, LX	-0.3- 23V
TIM	-0.3- 3.6V
RS	BAT-0.1V to BAT+0.1V
LX Pin Continuous Current	2A
Junction Temperature Range	-20°C to 125°C
Ambient Temperature Range	-40°C to 85°C



Electrical Characteristics

T_A=25°C, V_{IN}=15V, GND=0V, C_{IN}=10μF, L=6.8μH, R_S=25mΩ, C_{TIM}=330nF, unless otherwise specified.

Symbol	Parameter	Conditions	Min	Typ	Max	Unit
Bias Supply (V_{IN})						
V _{IN}	Supply Voltage		4.0		23	V
V _{UVLO}	V _{IN} Under Voltage Lockout Threshold	V _{IN} rising and measured from V _{IN} to GND			3.9	V
ΔV _{UVLO}	V _{IN} Under Voltage Lockout Hysteresis	Measured from V _{IN} to GND		190		mV
V _{OVLP}	Input Overvoltage Protection	V _{IN} rising and measured from V _{IN} to GND	23			V
ΔV _{OVLP}	Input Overvoltage Protection Hysteresis	Measured from V _{IN} to GND		750		mV
Quiescent Current						
I _{BAT}	Battery Discharge Current	Pull Down NTC			25	μA
I _{IN}	Input Leakage Current	Disable Charge			1.8	mA
Oscillator and PWM						
f _{OSC}	Oscillator Frequency		640	800	960	kHz
D	PFET Duty Cycle				100	%
Power MOSFET						
R _{NFET}	R _{DS(ON)} of N-FET	Include bond-wire		150		mΩ
R _{PFET}	R _{DS(ON)} of P-FET			160		mΩ
Voltage Regulation						
V _{CV}	Low VSET for 4.1V Cell Voltage		4.06	4.10	4.14	V
	High VSET for 4.4V Cell Voltage		4.35	4.4	4.45	
ΔV _{RCH}	4.1V CV Threshold for Recharge		35	100	150	mV
	4.4V CV Threshold for Recharge		85	150	210	
V _{TRK}	TC Charge Mode Voltage Threshold		2.2	2.5	2.8	V
Battery Connect Detection						
V _{DET}	NTC Voltage Threshold for Battery Detect	NTC Falling Edge	80%		90%	V _{IN}
t _{DET}	Detect Delay Time		30	35	40	ms
Charge Current						
I _{CHARGE}	Internal Charge Current Accuracy for Constant Current Mode	I _{CC} =25mV/R _S	-10%		10%	
	Internal Charge Current Accuracy for Trickle Current Mode	I _{TC} =2.5mV/R _S	-50%		50%	
Charge Termination						
I _{TERM}	Charge Termination Current			10%		I _{CC}
T _{TERM}	Termination Delay Time			30		ms
Input Current Limit Slow Response						
V _{INSL}	IN Voltage Falling Threshold at High Current			4.6		V
ΔV _{INSL}	IN Voltage Hysteresis at High Current			50		mV
Input Current Limit Quick Response						
ΔV	IN Voltage Falling Threshold at High Current			4.4		V
ΔV _{INQK}	IN Voltage Hysteresis at High Current			100		mV



SY20752B1

Output Voltage OVP						
V _{OVP}	Output Voltage OVP Threshold		4.66	4.8	4.96	V
Output Short Protection						
V _{SHOT}	Output Short Protection Threshold	V _{BAT} falling edge	1.70	2.00	2.30	V
f _{FBK}	Frequency Fold Back	V _{BAT} <2V		12.5%		f _{OSC}
I _{LM}	Power FET Current Limit			4		A
Timer						
t _{TC}	Trickle Current Charge Timeout	C _{TIM} =330nF	0.37	0.55	0.7	hour
t _{CC}	Constant Current Charge Timeout		3.3	5	6.7	hour
t _{MC}	Charge Mode Change Delay Time			30		ms
t _{RCHG}	Recharge Time Delay			30		ms
Battery Thermal Protection NTC						
UTP	Under Temperature Protection		70%	75%	80%	V _{IN}
	Under Temperature Protection Hysteresis	Falling edge		5%		
OTP	Over Temperature Protection		28%	30%	32%	
	Over Temperature Protection Hysteresis	Rising edge		2%		
Automatic Shutdown						
ΔV _{ASD}	ASD Voltage Threshold Hysteresis	Measured from V _{IN} to V _{BAT}		80		mV
Thermal Shutdown						
T _{SD}	Thermal Shutdown Temperature	Rising Threshold		160		°C
T _{SDHYS}	Thermal Shutdown Temperature Hysteresis			20		°C

Note 1: Stresses beyond the “Absolute Maximum Ratings” may cause permanent damage to the device. These are stress ratings only. Functional operation of the device at these or any other conditions beyond those indicated in the operational sections of the specification is not implied. Exposure to absolute maximum rating conditions for extended periods may affect device reliability.

Note 2: θ_{JA} is measured in the natural convection at T_A = 25°C on a low effective four-layer thermal conductivity test board of JEDEC 51-3 thermal measurement standard.

Note 3: The device is not guaranteed to function outside its operating conditions.

Basic Li-Ion Battery Charge Operation Flow Chart

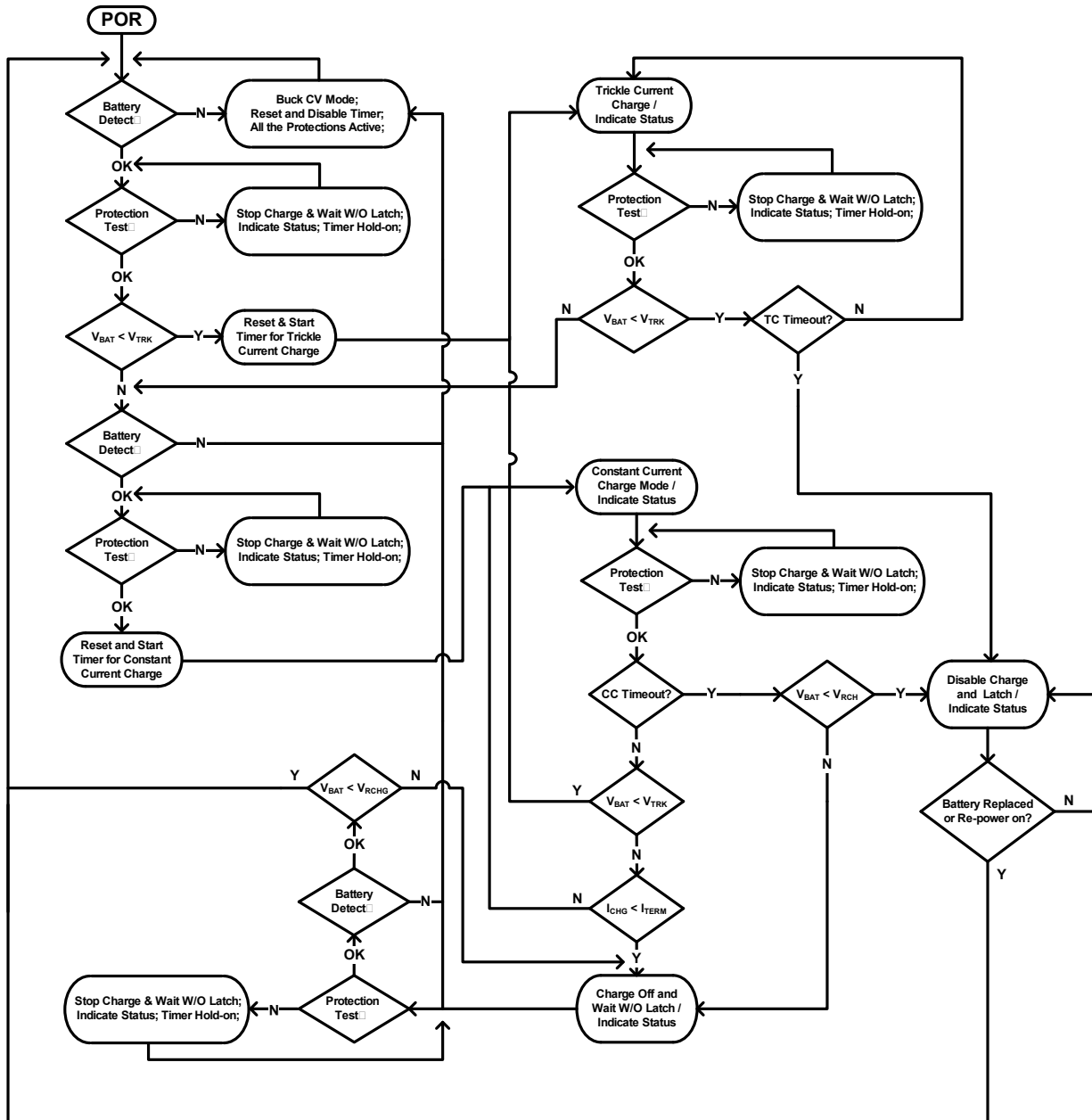

Figure 3. Figure



General Function Description

SY20752B1 is a 4.0-23V input, 2A single-cell synchronous Buck Li-Ion battery charger. The compact package SO8E is suitable for portable applications. VSET pin is convenient for selecting 4.4V or 4.1V cell voltage. The integrated 800 kHz synchronous Buck regulator consists of 25V rating FETs with extremely low on resistance to achieve high charge efficiency and simple peripheral circuit design.

Charging Status Indication Description

1. **Charge-in-process** – Pull and keep STAT pin to Low;
2. **Charge Done** – Pull and keep STAT pin to High;
3. **Fault Mode** – Output high and low voltage alternately at the frequency of 0.5Hz when the C_{TIM} is 330nF.

Connect a LED from VIN to STAT pin, LED on means charge-in-process, LED off means charge done, LED flash means fault mode.

Buck Regulator Operation Description

If the Li-Ion battery is removed suddenly, the voltage on NTC pin will increase higher than 90% of V_{IN} . Then, it will operate as a normal peak current mode controlled synchronous Buck converter and the output voltage on BAT pin will be regulated at V_{CV} . In this operation mode, the constant output current loop will still be active, however the charging timeout operation, the termination function, the trickle current charging will be disabled.

Protection Description

Thermal Protection-Thermal shutdown is active for battery and the IC. The IC will return to normal work

when the temperature returns in normal range. The timer will stop and hold on without reset.

Short Circuit Protection- When V_{BAT} is lower than the short circuit protection threshold, short circuit protection will be active. In charger operation mode, the switching frequency is folded back to 12.5% of the default value and V_C is folded back to 20% of the maximum value. The trickle charging timer is still active and would timeout the IC finally. In Buck operation mode, the switching frequency is folded back to 12.5% of the default value, and the VC initiates soft start periodically.

Over Current Protection- The internal current loop with different constant current capability is always active no matter in Buck mode or battery charging mode for over current protection.

Over Voltage Protection- When V_{BAT} voltage is higher than the over voltage protection threshold no matter with or without battery connected, The IC will shut down and return to normal work when VBAT returns to normal level. The input voltage has UVLO and OVP, which will make the IC shut down and return to normal work when V_{IN} returns to normal range.

Adaptive Input Current Limit- When the input is drawn from a USB port, SY20752B1 will adaptively limit the current if the input current is over the USB supply capability.

Timeout Protection-The programmable timeout protection is for both trickle current charge mode and constant current charge mode. Once timeout is active, the IC will stop the charge operation and latch off. Only re-plug in power source or re-place battery can reset the latch logic and return to normal work.

Typical Performance Characteristics

$T_A=25^{\circ}\text{C}$, $V_{IN}=5\text{V}$, $R_S=12.5\text{m}\Omega$, $V_{SET}=\text{GND}$, unless otherwise specified.

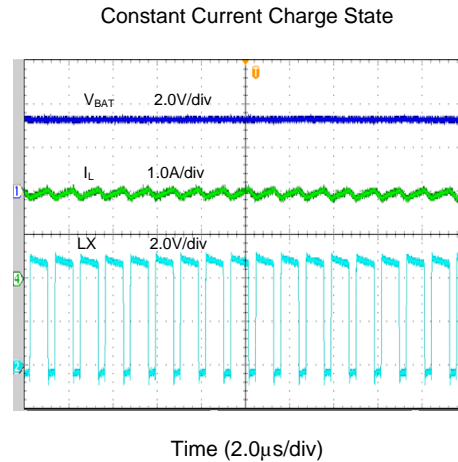
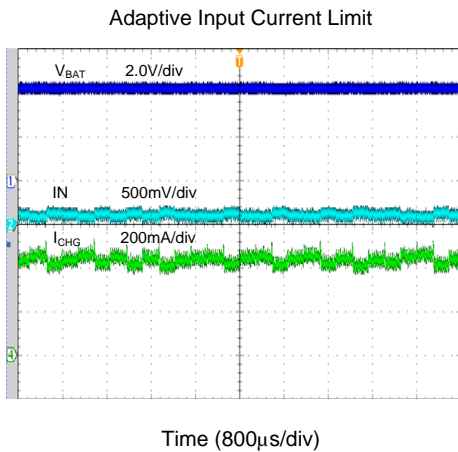
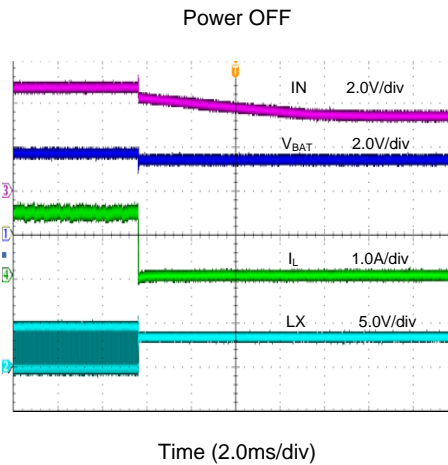
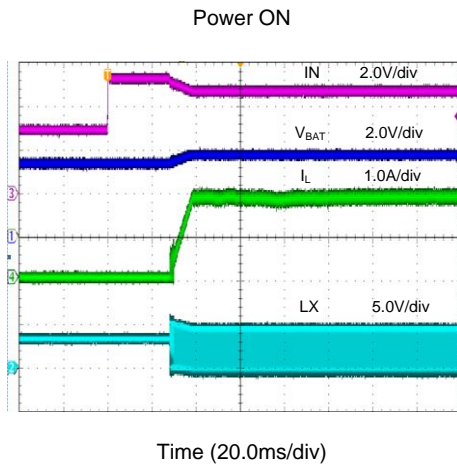
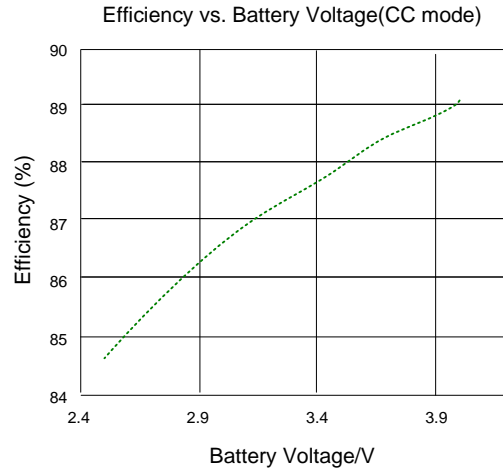
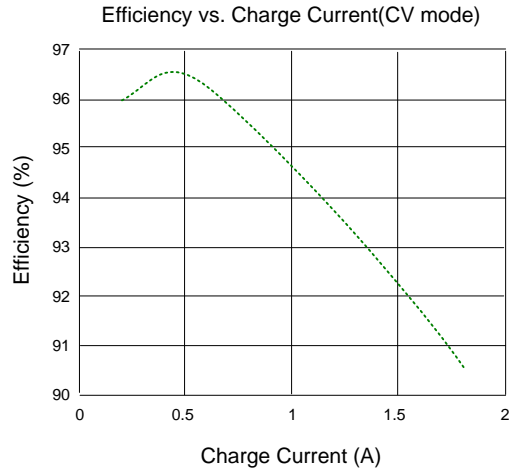

Battery Short

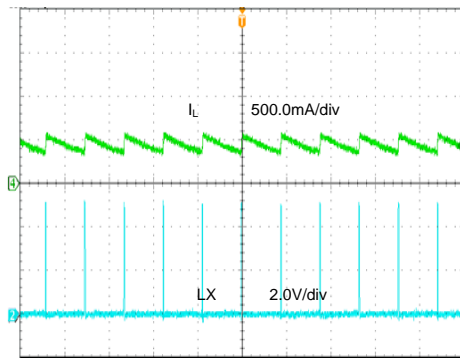

Time (10.0 μ s/div)

Buck Mode: Output Short

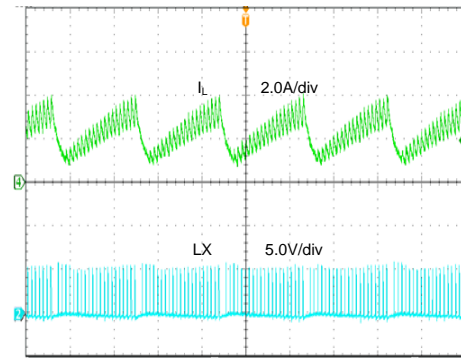

Time (100.0 μ s/div)

Applications Information

Because of the high integration of SY20752B1, the application circuit based on this regulator IC is rather simple. Only the input capacitor C_{IN} , the output capacitor C_{OUT} , the inductor L , the NTC resistors $R1, R2$, the charge current sense resistor R_S and the timer capacitor C_{TIM} need to be selected for the target applications specifications.

NTC Resistor:

SY20752B1 monitors battery temperature by measuring the input voltage and NTC voltage. The controller will trigger the UTP or OTP when the rate K ($K = V_{NTC}/V_{IN}$) reaches the threshold of UTP (K_{UT}) or OTP (K_{OT}). The temperature sensing network is showed as below.

Choose $R1$ and $R2$ to program the proper UTP and OTP points.

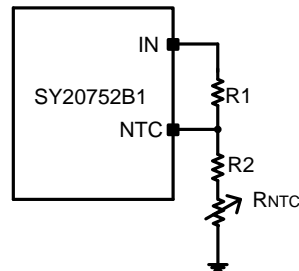

The calculation steps are:

1. Define K_{UT} , $K_{UT} = 70\sim 80\%$
2. Define K_{OT} , $K_{OT} = 28\sim 32\%$
3. Assume the resistance of the battery NTC thermistor is R_{UT} at UTP threshold and R_{OT} at OTP threshold.

4. Calculate $R2$,

$$R2 = \frac{K_{OT}(1 - K_{UT})R_{UT} - K_{UT}(1 - K_{OT})R_{OT}}{K_{UT} - K_{OT}}$$

5. Calculate $R1$

$$R1 = (1/K_{OT} - 1)(R2 + R_{OT})$$

If we choose the typical values $K_{UT} = 75\%$ and $K_{OT} = 30\%$, then

$$R2 = 0.17R_{UT} - 1.17R_{OT}$$

$$R1 = 2.3(R2 + R_{OT})$$

Charge Current Sense Resistor R_S

The charge current sense resistor R_S is calculated as below:

$$R_S = \frac{25}{I_{CC}}, \quad \text{Unit: m}\Omega$$

Where the I_{CC} is the battery constant charge current, the unit is ampere.

Timer Capacitor C_{TIM} :

The charger also provides a programmable charge timer. The charge time is programmed by the capacitor connected between the TIM pin and GND pin. The capacitance is given by the formula:

$$C_{TIM} = 2 \times 10^{-11} T_{CC} \quad \text{Unit: F}$$

T_{CC} is the target constant charge time, the unit is second.

Input Capacitor C_{IN} :

The ripple current through the input capacitor is greater than

$$I_{CIN_MIN} = I_{CC} \sqrt{D(1-D)}$$

Where the I_{CHG} is the battery constant charge current, measured in ampere.

To minimize the potential noise problem, we can place a typical X7R or a better grade ceramic capacitor really close to the IN and GND pins. Care should be taken to minimize the loop area formed by C_{IN} , and IN/GND pins.

Output Capacitor C_{OUT} :

The output capacitor is selected to handle the output ripple noise requirements. Both steady state ripple and transient requirements must be taken into consideration when selecting this capacitor. For the best performance, it is recommended to use X7R or better grade ceramic capacitor with $10\mu F$ capacitance

Output Inductor L :

There are several considerations in choosing this inductor.

- 1) Choose the inductance to provide the desired ripple current. It is suggested to choose the ripple current to be about 40% of the average input current. The inductance is calculated as:

$$L = \frac{V_{OUT}(1 - V_{OUT}/V_{IN,MAX})}{F_{SW} \times I_{OUT,MAX} \times 40\%}$$

Where F_{sw} is the switching frequency and $I_{OUT,MAX}$ is the maximum load current.

The SY20752B1 regulator IC is quite tolerant of different ripple current amplitudes. Consequently, the final choice of inductance can be slightly off the calculation value without significantly impacting the performance.

- The saturation current rating of the inductor must be selected to be greater than the peak inductor current under full load conditions.

$$I_{SAT,MIN} > I_{OUT,MAX} + \frac{V_{OUT}(1 - V_{OUT}/V_{IN,MAX})}{2 \times F_{sw} \times L}$$

- The DCR of the inductor and the core loss at the switching frequency must be low enough to achieve the expectant efficiency. It is desirable to choose an inductor with $DCR < 10\text{mohm}$ to achieve good overall efficiency.

Layout Design:

The layout design of SY20752B1 regulator is relatively simple. For the best efficiency and to minimum noise problems, we should place the following components close to the IC: C_{IN} , L.

- It is desirable to maximize the PCB copper area adjacent to GND pin to achieve the best thermal

performance and noise performance. If the board space is allowed, a ground plane is highly desirable.

- C_{IN} must be close to Pins IN and GND. The loop area formed by C_{IN} and GND must be minimized. The following picture is the recommended layout design of C_{IN} .

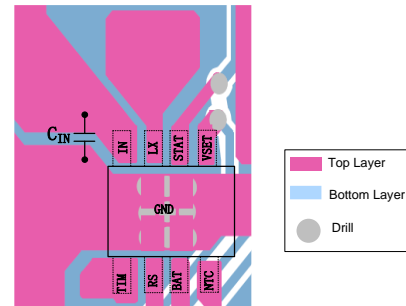

- The PCB copper area adjacent to LX pin must be minimized to avoid the potential noise problem.

- The capacitor C_{TIM} and the trace adjacent to the TIM pin must not be adjacent to the LX net on the PCB layout to avoid the noise problem. It should be better to ground C_{TIM} to the output capacitor's ground.

SO8E Package Outline & PCB layout

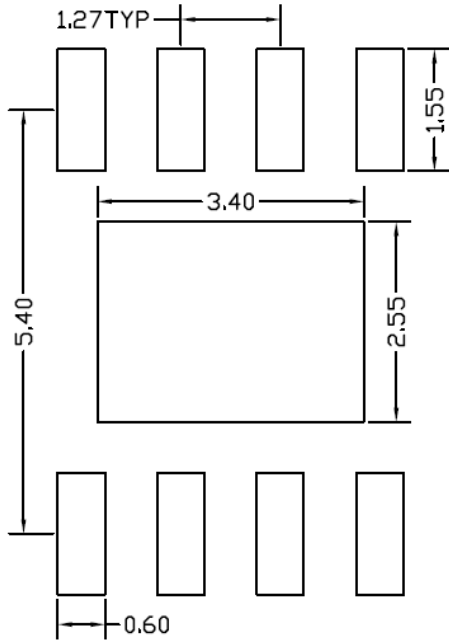

Recommended Pad Layout

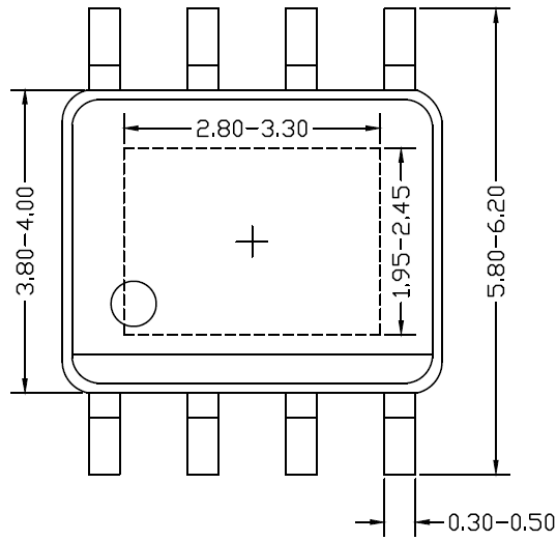

Top view

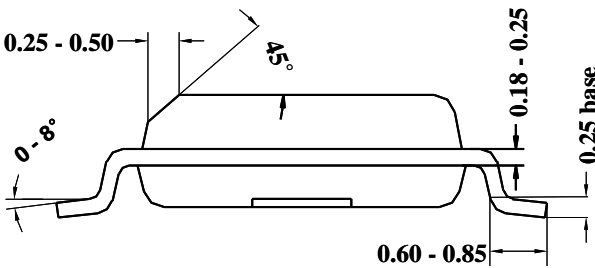

Side view

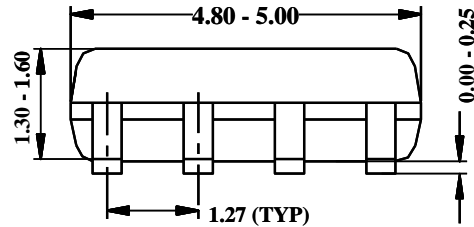

Notes: All dimension in millimeter and exclude mold flash & metal burr

Taping & Reel Specification

1. Taping orientation

SO8E

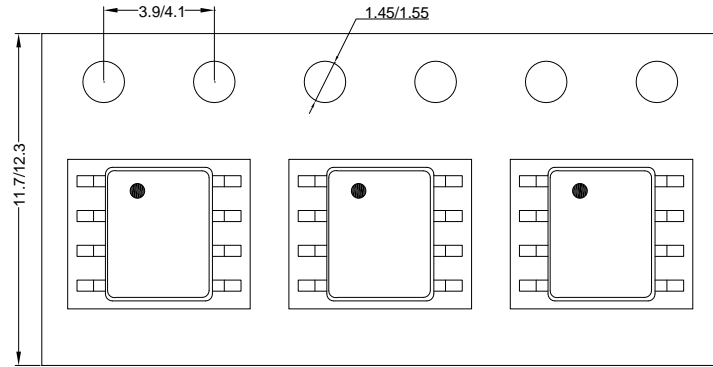

Feeding direction →

2. Carrier Tape & Reel specification for packages

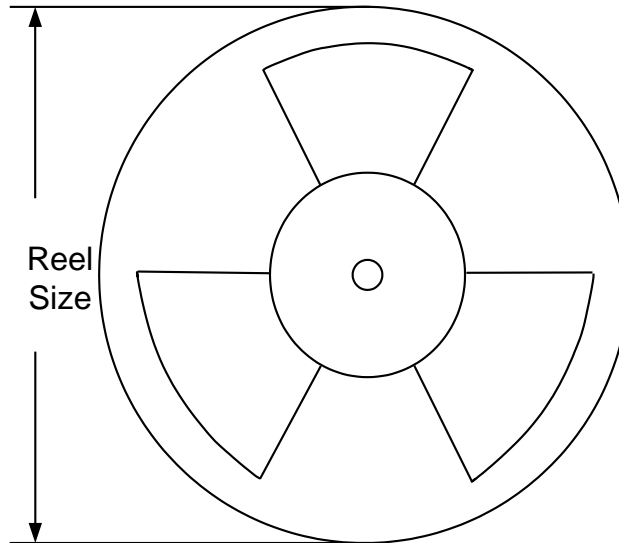

Package types	Tape width (mm)	Pocket pitch(mm)	Reel size (Inch)	Trailer length(mm)	Leader length (mm)	Qty per reel
SO8E	12	8	13"	400	400	2500

3. Others: NA



IMPORTANT NOTICE

- 1. Right to make changes.** Silergy and its subsidiaries (hereafter Silergy) reserve the right to change any information published in this document, including but not limited to circuitry, specification and/or product design, manufacturing or descriptions, at any time and without notice. This document supersedes and replaces all information supplied prior to the publication hereof. Buyers should obtain the latest relevant information before placing orders and should verify that such information is current and complete. All semiconductor products are sold subject to Silergy's standard terms and conditions of sale.
- 2. Applications.** Application examples that are described herein for any of these products are for illustrative purposes only. Silergy makes no representation or warranty that such applications will be suitable for the specified use without further testing or modification. Buyers are responsible for the design and operation of their applications and products using Silergy products. Silergy or its subsidiaries assume no liability for any application assistance or designs of customer products. It is customer's sole responsibility to determine whether the Silergy product is suitable and fit for the customer's applications and products planned. To minimize the risks associated with customer's products and applications, customer should provide adequate design and operating safeguards. Customer represents and agrees that it has all the necessary expertise to create and implement safeguards which anticipate dangerous consequences of failures, monitor failures and their consequences, lessen the likelihood of failures that might cause harm and take appropriate remedial actions. Silergy assumes no liability related to any default, damage, costs or problem in the customer's applications or products, or the application or use by customer's third-party buyers. Customer will fully indemnify Silergy, its subsidiaries, and their representatives against any damages arising out of the use of any Silergy components in safety-critical applications. It is also buyers' sole responsibility to warrant and guarantee that any intellectual property rights of a third party are not infringed upon when integrating Silergy products into any application. Silergy assumes no responsibility for any said applications or for any use of any circuitry other than circuitry entirely embodied in a Silergy product.
- 3. Limited warranty and liability.** Information furnished by Silergy in this document is believed to be accurate and reliable. However, Silergy makes no representation or warranty, expressed or implied, as to the accuracy or completeness of such information and shall have no liability for the consequences of use of such information. In no event shall Silergy be liable for any indirect, incidental, punitive, special or consequential damages, including but not limited to lost profits, lost savings, business interruption, costs related to the removal or replacement of any products or rework charges, whether or not such damages are based on tort or negligence, warranty, breach of contract or any other legal theory. Notwithstanding any damages that customer might incur for any reason whatsoever, Silergy' aggregate and cumulative liability towards customer for the products described herein shall be limited in accordance with the Standard Terms and Conditions of Sale of Silergy.
- 4. Suitability for use.** Customer acknowledges and agrees that it is solely responsible for compliance with all legal, regulatory and safety-related requirements concerning its products, and any use of Silergy components in its applications, notwithstanding any applications-related information or support that may be provided by Silergy. Silergy products are not designed, authorized or warranted to be suitable for use in life support, life-critical or safety-critical systems or equipment, nor in applications where failure or malfunction of an Silergy product can reasonably be expected to result in personal injury, death or severe property or environmental damage. Silergy assumes no liability for inclusion and/or use of Silergy products in such equipment or applications and therefore such inclusion and/or use is at the customer's own risk.
- 5. Terms and conditions of commercial sale.** Silergy products are sold subject to the standard terms and conditions of commercial sale, as published at <http://www.silergy.com/stdterms>, unless otherwise agreed in a valid written individual agreement specifically agreed to in writing by an authorized officer of Silergy. In case an individual agreement is concluded only the terms and conditions of the respective agreement shall apply. Silergy hereby expressly objects to and denies the application of any customer's general terms and conditions with regard to the purchase of Silergy products by the customer.
- 6. No offer to sell or license.** Nothing in this document may be interpreted or construed as an offer to sell products that is open for acceptance or the grant, conveyance or implication of any license under any copyrights, patents or other industrial or intellectual property rights. Silergy makes no representation or warranty that any license, either express or implied, is granted under any patent right, copyright, mask work right, or other intellectual property right. Information published by Silergy regarding third-party products or services does not constitute a license to use such products or services or a warranty or endorsement thereof. Use of such information may require a license from a third party under the patents or other intellectual property of the third party, or a license from Silergy under the patents or other intellectual property of Silergy.

For more information, please visit: www.silergy.com

© 2018 Silergy Corp.

All Rights Reserved.