

General Description

SY20761 is a 3.6-5.5V_{IN}, 1.2A two-cell synchronous Boost Li-Ion battery charger which integrates 1MHz switching frequency and full protection functions. The charge current up to 1.2A can be programmed by using the external resistor for different portable applications and indicates the charger current information simultaneously. It also has a programmable charge timeout for safety battery charge operation and a programmable input voltage threshold for adaptive input current limit. SY20761 can disconnect output when there is an output short circuit or shutdown. It consists of 18V rating FETs with extremely low on resistance to achieve high charge efficiency and simple peripheral circuit design.

SY20761 along with small QFN3×3 footprint provides small PCB area application.

Ordering Information

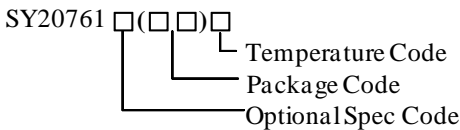

Ordering Number	Package type	Note
SY20761QDC	QFN3×3-16	

Features

- Low Profile QFN3×3 Package
- Integrated Synchronous Boost with 18V Rating Low R_{DS(on)} FETs for High Charge Efficiency
- Trickle Current / Constant Current / Constant Voltage Charge Mode
- Programmable Input Voltage Threshold for Adaptive Current Limit.
- Maximum 1.2A Constant Charge Current
- Charge Current Information Indication.
- Programmable Charge Timeout
- Programmable Constant Charge Current
- Selectable Constant Voltage
- ±0.5% Battery Voltage Accuracy
- Thermal Regulation Protection
- External Shutdown Function
- Input Voltage UVLO and OVP
- Over Temperature Protection
- Output Short Circuit Protection
- Charge Status Indication
- Normal Synchronous Boost Operation When the Battery is Removed

Applications

- Cellular Telephones, PDA, MP3 Players, MP4 Players
- Digital Cameras
- Bluetooth Applications
- PSP Game Players, NDS Game Players
- Notebook

Typical Applications

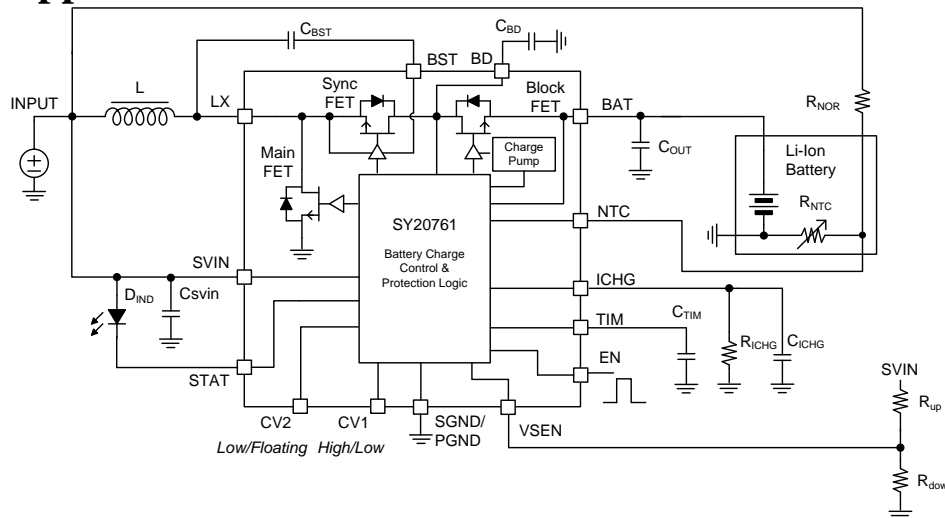
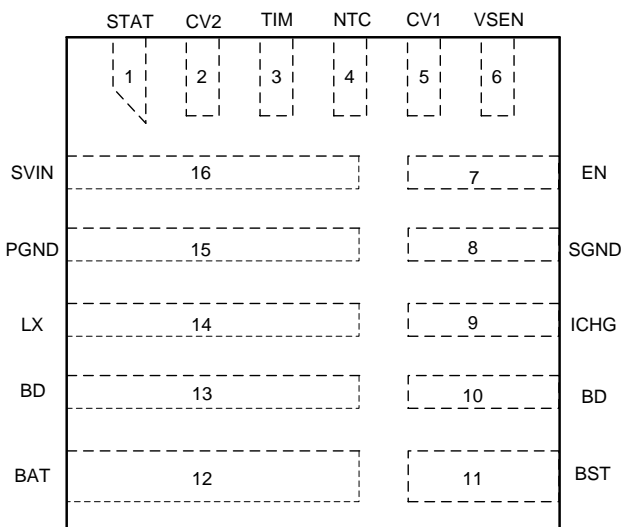

Figure1. Schematic Diagram

Pinout (top view)

(QFN3×3-16)

Top Mark: **cRxyz**, (Device code: cR, *x*=year code, *y*=week code, *z*=lot number code)

Name	Pin Number	Description
STAT	1	Charge status indication pin. It is open-drain output pin and pulled high to SVIN through a LED to indicate the charge in process. When the charge is done, the LED will be off.
CV2	2	Battery CV voltage selection pin. Program 4 different CV thresholds by setting different voltage on this pin and pin5. Floating or grounding this pin in the application. CV2 pin can't be pulled high to any bias voltage higher than 3.3V.
TIM	3	Charge time limit pin. Connect this pin with a capacitor to ground. Internal current source charge the capacitor for TC mode and CC mode's charge time limit. TC charge time limit is about 1/9 of CC charge time.
NTC	4	Thermal protection pin. UTP threshold is typical 76% of V _{SVIN} and OTP threshold is typical 30.5% of V _{SVIN} . Pull up to SVIN can disable charge logic and make the IC operate as a normal Boost regulator. Pull down to ground can shut down the IC.
CV1	5	Battery CV voltage selection pin. Program 4 different CV thresholds by setting different voltage on this pin and pin2. The detailed information is shown in description section.
VSEN	6	Voltage sense of SVIN. If the voltage drops to internal 1.195V reference voltage, the SVIN will be clamped to setting value and input current will be limited.
EN	7	Enable control pin. High logic for enable on, and low logic for enable off.
SGND	8	Signal ground pin.
ICHG	9	Charge current program pin. Pull down to GND with a resistor R _{ICHG} . The mirror current about 1/10000 of the blocking FET current will dump into the external RC network through ICHG pin and compared to the internal reference 1V. So $I_{CC} = (1V / R_{ICHG}) \times 10000$, $I_{TC} = (1V / R_{ICHG}) \times 1000 + 0.02$.
BD	10, 13	Connect it to the drain of internal blocking FET. Bypass at least a 4.7μF ceramic cap to GND.
BST	11	Boost-strap pin. Supply rectified FET's gate driver. Decouple this pin to LX with a 0.1μF ceramic cap.
BAT	12	Battery positive pin.
LX	14	Switch node pin. Connect it to the external inductor.
PGND	15	Power ground pin.
SVIN	16	Analog power input pin. Connect a MLCC from this pin to ground to decouple high harmonic noise. This pin has OVP and UVLO function to make the charger operate within safe input voltage range.



Absolute Maximum Ratings (Note1)

STAT, NTC, CV1, VSEN, EN, ICHG, BD, BAT, LX, SVIN	18V
CV2, TIM, BST-LX	4V
LX Pin Continuous Current	5A
Power Dissipation, P _D @ T _A = 25°C, QFN3×3	2.6W
Package Thermal Resistance (Note2)	
θ _{JA}	38°C/W
θ _{JC}	4°C/W
Junction Temperature Range	-40°C to 125°C
Lead Temperature (Soldering, 10 sec.)	260°C
Storage Temperature Range	-65°C to 125°C

Recommended Operating Conditions (Note3)

SVIN	3.6V to 5.5V
STAT, NTC, CV1, VSEN, EN, ICHG, BD, BAT, LX,	-0.3V to 16V
CV2, TIM, BST-LX	-0.3V to 3.3V
LX Pin Continuous Current	5A
Junction Temperature Range	-40°C to 125°C
Ambient Temperature Range	-40°C to 85°C



Electrical Characteristics

T_A=25°C, V_{IN}=5V, GND=0V, C_{IN}=4.7μF, L=0.68μH, R_{CHG}=10kΩ, C_{TIM}=470nF, unless otherwise specified.

Parameter	Symbol	Conditions	Min	Typ	Max	Unit
Bias Supply (V_{SVIN})						
Supply Voltage	V _{SVIN}		3.6		16	V
V _{SVIN} Under Voltage Lockout Threshold	V _{UVLO}	V _{SVIN} rising and measured from V _{SVIN} to GND			3.6	V
V _{SVIN} Under Voltage Lockout Hysteresis	ΔV _{UVLO}	Measured from V _{SVIN} to GND		100		mV
Input Over Voltage Protection	V _{OVF}	V _{SVIN} rising and measured from V _{SVIN} to GND	5.8			V
Input Over Voltage Protection Hysteresis	ΔV _{OVF}	Measured from V _{SVIN} to GND		0.5		V
Quiescent Current						
Battery Discharge Current	I _{BAT}	Shut down IC, EN=NTC=0			10	μA
Input Quiescent Current	I _{IN}	Disable charge, EN=1,NTC=0			1.5	mA
Oscillator and PWM						
Switching Frequency	f _{SW}			1000		kHz
Main N-FET Minimum Off Time	t _{MIN_OFF}	With 18V rating		100		ns
Main N-FET Maximum Off Time	t _{MAX_OFF}	With 18V rating		30		μs
Main N-FET Minimum On Time	t _{MIN_ON}	With 18V rating		100		ns
Power MOSFET						
R _{DS(ON)} of Main N-FET	R _{NFET_M}			100		mΩ
R _{DS(ON)} of Rectified N-FET	R _{NFET_R}			50		mΩ
R _{DS(ON)} of Blocking N-FET	R _{NFET_B}			50		mΩ
Voltage Regulation						
Battery Charge Voltage	V _{BAT_REG}	V _{CV1} >1.5V, V _{CV2} is floating	8.159	8.2	8.241	V
		V _{CV1} <0.4V, V _{CV2} is floating	8.358	8.4	8.442	
		V _{CV1} >1.5V, V _{CV2} <0.4V	8.656	8.7	8.743	
		V _{CV1} <0.4V, V _{CV2} <0.4V	8.756	8.8	8.844	
High Level Logic for CV1	V _{CV_H}		1.5			V
Low Level Logic for CV1,CV2	V _{CV_L}				0.4	V
Recharge Threshold Refer to V _{BAT_REG}	ΔV _{RCH}		100	200	300	mV
Trickle Current Charge Mode Battery Voltage Threshold	V _{TRK}	Rising edge threshold	5.4	5.6	5.8	V



Battery Connect Detection						
NTC Voltage Threshold for Battery Detect	V_{DET}	NTC Falling Edge	85%		95%	V_{SVIN}
Detect Delay Time	t_{DET}			30		ms
Charge Current						
Internal Charge Current Accuracy for Constant Current Mode		$I_{CC}=1000mA$	-10		10	%
Internal Charge Current Accuracy for Trickle Current Mode		$I_{TC}=120mA$	-50		50	%
Termination Current	I_{TERM}	$I_{CC}=1000mA$	50	100	150	mA
Output Voltage OVP						
Output Voltage OVP Threshold	V_{OVP}		105%	110%	115%	V_{BAT_REG}
Input Voltage Threshold for Adaptive Current Limit						
Voltage Reference of VSEN	V_{SEN}		1.17	1.195	1.22	V
Timer						
Trickle Current Charge Timeout	t_{TC}	$C_{TIM}=330nF$	0.4	0.5	0.65	hour
Constant Current Charge Timeout	t_{CC}		3.8	4.5	5.82	hour
Charge Mode Change Delay Time	t_{MC}			30		ms
Termination Delay Time	t_{TERM}			30		ms
Recharge Time Delay	t_{RCHG}			30		ms
Short Circuit Protection						
Output Short Protection Threshold	V_{SHORT}		1.70	2.00	2.30	V
Linear Charger Mode						
Battery Charger Current When the Blocking FET is in Linear Mode	I_{SC}	$V_{BAT}<V_{SHORT}$	4%	10%		I_{CC}
BD Voltage Regulation	V_{BD}	$V_{SHORT}<V_{BAT}<V_{TRK}$	5.8	6	6.2	V
Enable ON/OFF Control						
High Level Logic for Enable Control	V_{EN_H}		1.5			V
Low Level Logic for Enable Control	V_{EN_L}				0.4	V
Battery Thermal Protection NTC						
Under Temperature Protection	V_{NTC_UTP}		75%	76%	77%	V_{SVIN}
Under Temperature Protection Hysteresis	$V_{NTC_UTP_HYS}$	Falling edge		6%		
Over Temperature Protection	V_{NTC_OTP}		29.5%	30.5%	31.5%	
Over Temperature Protection Hysteresis	$V_{NTC_OTP_HYS}$	Rising edge		2%		
Thermal Fold-back and Thermal Shutdown						
Thermal Fold-back Threshold	T_{Fold}	Rising edge		120		°C
Thermal Fold-back Threshold Hysteresis	T_{Fold_HYS}			20		°C
Thermal Fold-back Ratio				0.25		I_{CC}
Thermal Shutdown Temperature	T_{SD}	Rising edge		160		°C
Thermal Shutdown Temperature Hysteresis	T_{SD_HYS}			30		°C

Note 1: Stresses beyond the “Absolute Maximum Ratings” may cause permanent damage to the device. These are stress ratings only. Functional operation of the device at these or any other conditions beyond those indicated in the



SY20761

operational sections of the specification is not implied. Exposure to absolute maximum rating conditions for extended periods may affect device reliability.

Note 2: θ_{JA} is measured in the natural convection at $T_A = 25^\circ\text{C}$ on a low effective four-layer thermal conductivity test board of JEDEC 51-3 thermal measurement standard.

Note 3: The device is not guaranteed to function outside its operating conditions.

Typical Performance Characteristics

($T_A=25^\circ\text{C}$, $V_{IN}=5\text{V}$, $R_{CHG}=10\text{k}\Omega$, unless otherwise specified.)

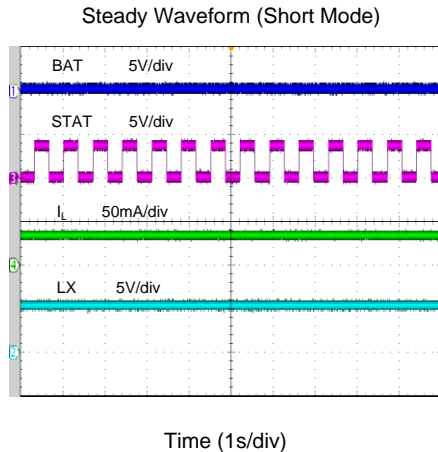
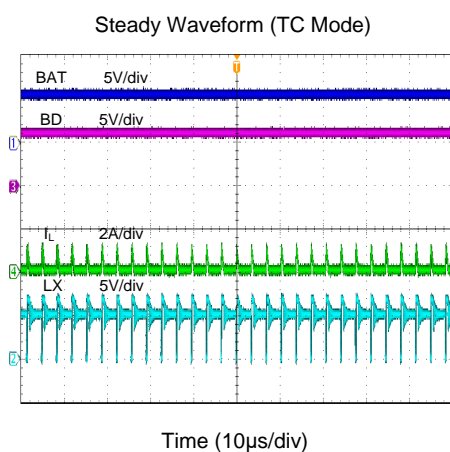
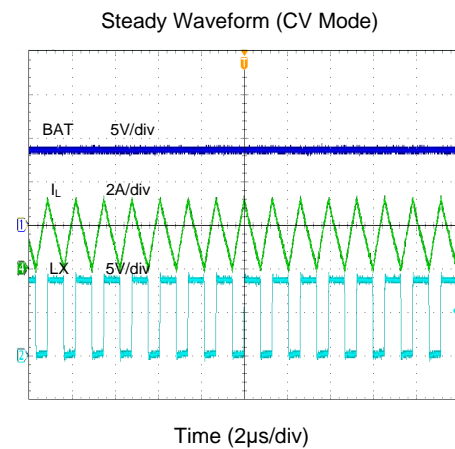
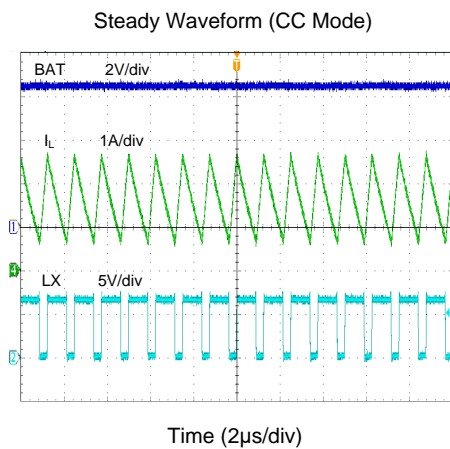
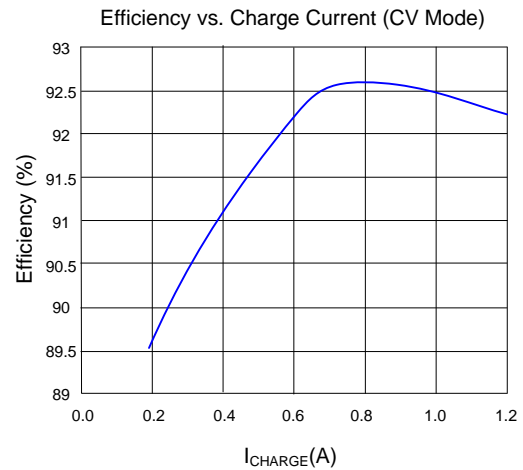
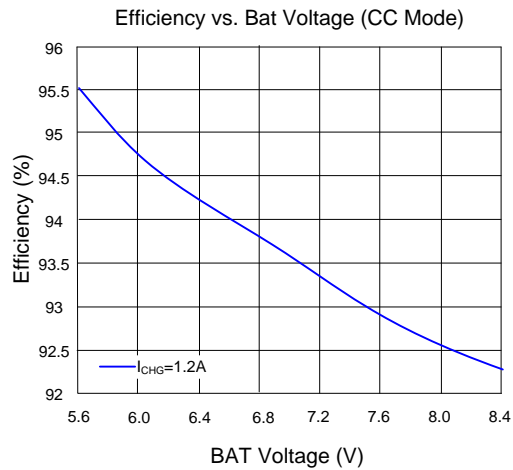

Power ON (CC Mode)

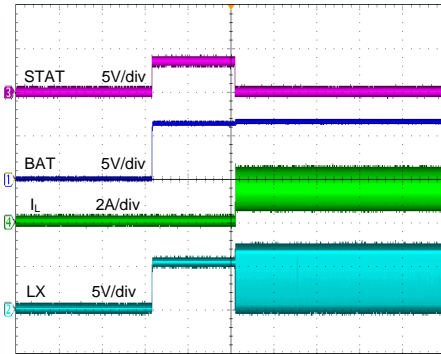

Time (400ms/div)

Power OFF (CC Mode)

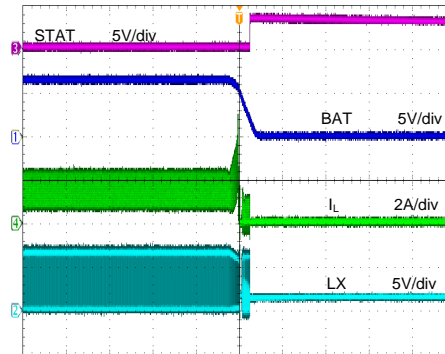

Time (2ms/div)

Power ON (CV Mode)

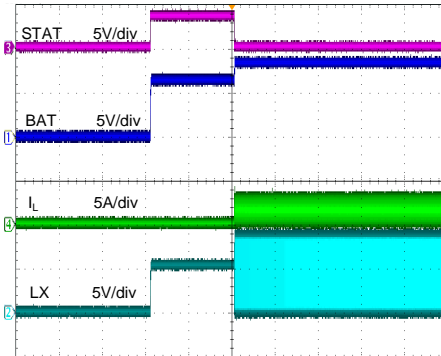

Time (400ms/div)

Power OFF (CV Mode)

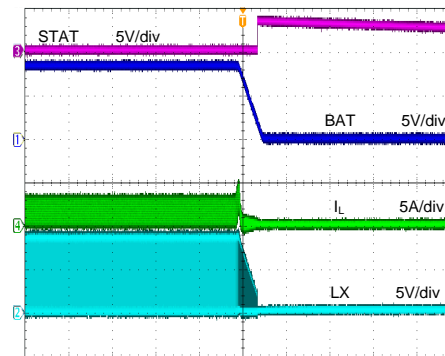

Time (4ms/div)

Adaptive Input Current Limit
(5V/1A Adapter)

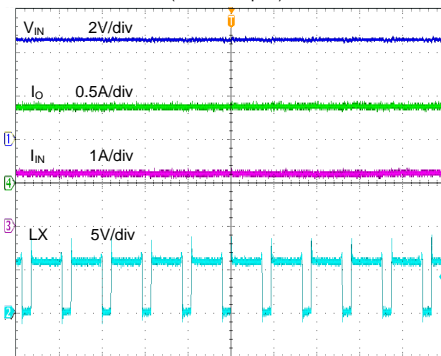

Time (1μs/div)

Boost Mode (Null load)

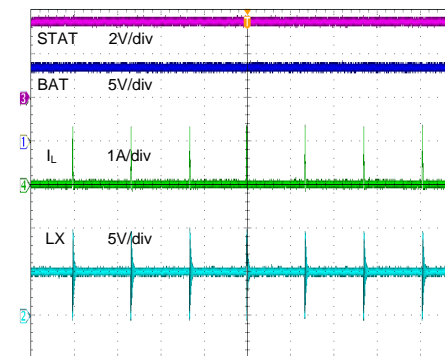

Time (20μs/div)



General Function Description

SY20761 is a 3.6-5.5V_{IN}, 1.2A two-cell synchronous Boost Li-Ion battery charger which integrates 1MHz switching frequency and full protection functions. The charge current up to 1.2A can be programmed by using the external resistor for different portable applications and indicates the charger current information simultaneously. It also has a programmable charge timeout for safety battery charge operation and a programmable input voltage threshold for adaptive input current limit. SY20761 can disconnect output when there is an output short circuit or shutdown. It consists of 18V rating FETs with extremely low on resistance to achieve high charge efficiency and simple peripheral circuit design.

Charging Status Indication Description

1. Charge-in-process – Pull and keep STAT pin low;
2. Charge Done – Pull and keep STAT pin high;
3. Fault Mode – Output high and low voltage alternatively at the frequency of 1.3Hz. Connect a LED from SVIN to STAT pin, LED on means charge-in-process, LED off means charge done, LED flashing at 1.3Hz means fault mode.
Fault Mode includes Input OVP, BAT OVP, BAT Short Circuit, NTC(UTP/OTP), Thermal Shutdown and Charge Timeout.

Switching Mode Boost Charger Basic Operation Description

Switching Mode Control Strategy

SY20761 is a switching mode Boost charger for the applications with USB power input. The 1MHz fixed frequency is easy for the size minimization of peripheral circuit design.

Operation Principle

SY20761 can normally work with or without Li-Ion battery.

Battery Present

When the battery is present, SY20761 will work on trickle current charge, constant current charge and constant voltage charge mode according to the battery voltage.

Battery Absent

If there's no battery connection detected through NTC pin, SY20761 will operate as a normal switching mode Boost converter. The internal

constant current loop and voltage loop are active both.

Basic Protection Principle

SY20761 has fully battery charging protection. When the input over voltage protection, the output over voltage protection, the thermal protection or the timeout protection happens, the Boost charger will stop switching immediately. When the V_{BAT} is lower than V_{SHORT}, the short circuit protection will happen. The main FET will be turned off firstly. The block FET will enter linear mode with 1/10 of I_{CC} charging current. When V_{BAT} returns to be higher than V_{SHORT}, the Boost charger will restart to work at light load and regulate V_{BD} at 6V. The linear charge current will keep 1/10 I_{CC}. When V_{BAT} returns to be higher than V_{TRK}, the Boost switching charger will take over.

Adaptive Input Current Limit Principle

SY20761 can protect the input DC source from over load by the special loop control. The high charging current will cause a voltage drop at SVIN when the input DC source is over load. When VSEN drops below the internal 1.195V reference, SY20761 will decrease the duty cycle to reduce the charging current.

Constant Voltage Threshold Program Principle

SY20761 can program the constant voltage threshold thru the CV1 and CV2. When V_{CV1} is higher than 1.5V and CV2 is floating, the constant voltage threshold is 8.2V; when V_{CV1} is lower than 0.4V and CV2 is floating, the constant voltage threshold is 8.4V; when V_{CV1} is high than 1.5V and V_{CV2} is lower than 0.4V, the constant voltage threshold is 8.7V; when V_{CV1} and V_{CV2} are lower than 0.4V both, the constant voltage threshold is 8.8V.

Applications Information

Because of the high integration of SY20761, the application circuit based on this regulator IC is rather simple. Only input capacitor C_{IN}, output capacitor C_{OUT}, inductor L, NTC resistors R1, R2, input voltage threshold resistors R_{UP}, R_{DOWN} and timer capacitor C_{TIM} need to be selected for the target applications specifications.

NTC Resistor

SY20761 monitors battery temperature by measuring the input voltage and NTC voltage. The controller will trigger the UTP or OTP when the rate K (K=V_{NTC}/V_{SVIN}) reaches the threshold of UTP (K_{UT}) or OTP (K_{OT}). The temperature sensing network is showed as below.

Choose R1 and R2 to program the proper UTP and OTP points.

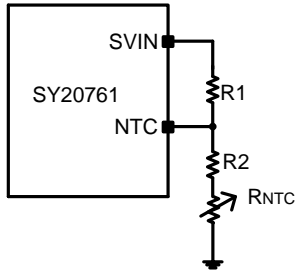

The calculation steps are:

1. Define K_{UT} , $K_{UT} = 75 \sim 77\%$
2. Define K_{OT} , $K_{OT} = 29.5 \sim 31.5\%$
3. Assume the resistance of the battery NTC thermistor is R_{UT} at UTP threshold and R_{OT} at OTP threshold.
4. Calculate R2,

$$R_2 = \frac{K_{OT}(1-K_{UT})R_{UT} - K_{UT}(1-K_{OT})R_{OT}}{K_{UT} - K_{OT}}$$

5. Calculate R1
 $R_1 = (1/K_{OT} - 1)(R_2 + R_{OT})$

If choose the typical values $K_{UT} = 76\%$ and $K_{OT} = 30.5\%$, then

$$R_2 = 0.16R_{UT} - 1.16R_{OT}$$

$$R_1 = 2.3(R_2 + R_{OT})$$

Input Voltage Threshold for Adaptive Current Limit

SY20761 will monitor input voltage by measuring the VSEN voltage, when VSEN drops below the internal 1.195V reference, SY20761 will decrease the duty cycle to reduce the charging current.

The input voltage sense network shows below, choose R_{UP} , R_{DOWN} to set the input voltage threshold V_{INT} :

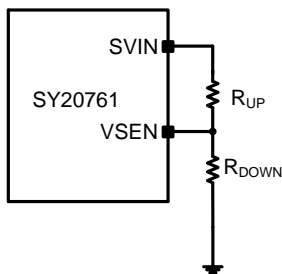

$$V_{INT} = \frac{V_{SEN} \times (R_{down} + R_{up})}{R_{down}} \quad \text{unit: V}$$

V_{SEN} is 1.195V.

Timer Capacitor C_{TIM}

The charger also provides a programmable charge timer. The charge time is programmed by the capacitor connected between the TIM pin and GND. The capacitance is given by the formula:

$$C_{TIM} = 2 \times 10^{-11} S \times T_{CC} \quad \text{unit: F}$$

T_{CC} is the target constant charge time, unit: s.

Input Capacitor C_{IN}

The ripple current through input capacitor is greater than

$$I_{C_{IN-RMS}} = \frac{V_{IN} \times (V_{OUT} - V_{IN})}{2\sqrt{3} \times L \times F_{SW} \times V_{OUT}}$$

X5R or X7R ceramic capacitors with greater than $4.7\mu F$ capacitance are recommended to handle this ripple current.

Output Capacitor C_{OUT}

The output capacitor is selected to handle the output ripple noise requirements. This ripple voltage is related to the capacitance and its equivalent series resistance (ESR). For the best performance, it is recommended to use X5R or a better grade low ESR ceramic capacitor. The voltage rating of the output capacitor should be higher than the maximum output voltage. The minimum required capacitance can be calculated as:

$$C_{OUT} = \frac{I_{CC} \times (V_{OUT} - V_{IN})}{F_{SW} \times V_{OUT} \times V_{RIPPLE}}$$

V_{RIPPLE} is the peak to peak output ripple, I_{CC} is the setting charge current.

For SY20761, output capacitor is paralleled by C_{BD} and C_{BAT} , for smaller output ripple noise, each capacitor with greater than $10\mu F$ capacitance is recommended.

Inductor L

There are several considerations in choosing this inductor.

- 1) Choose the inductance to provide the desired ripple current. It is suggested to choose the ripple current to be about 40% of the average input current. The inductance is calculated as:

$$L = \left(\frac{V_{IN}}{V_{OUT}} \right)^2 \frac{(V_{OUT} - V_{IN})}{I_{CC} \times F_{SW} \times 40\%}$$

Where F_{SW} is the switching frequency and I_{CC} is the setting charge current.

The SY20761 is quite tolerant of different ripple current amplitudes. Consequently, the final choice of inductance can be slightly off the calculation value without significantly impacting the performance.

- The saturation current rating of the inductor must be selected to be greater than the peak inductor current under full load conditions.

$$I_{SAT,MIN} > \left(\frac{V_{OUT}}{V_{IN}} \right) \times I_{CC} + \left(\frac{V_{IN}}{V_{OUT}} \right) \times \frac{(V_{OUT} - V_{IN})}{2 \times F_{SW} \times L}$$

- The DCR of the inductor and the core loss at the switching frequency must be low enough to achieve the desired efficiency requirement. It is desirable to choose an inductor with DCR < 10mohm to achieve a good overall efficiency.

Layout Design

The layout design of SY20761 regulator is relatively simple. For the best efficiency and to minimize noise

problems, we should place the following components close to the IC: C_{SVIN}, L, C_{BD}.

- The loop of main MOSFET, rectifier diode, and C_{BD} must be as short as possible
- It is desirable to maximize the PCB copper area connected to GND pin to achieve the best thermal and noise performance.
- C_{SVIN} must be close to pin SVIN and GND.
- The PCB copper area associated with LX pin must be minimized to avoid the potential noise problem.
- The small signal components R_{ICHG}, R_{UP} and R_{DOWN} must be placed close to the IC and must not be adjacent to the LX net on the PCB layout to avoid the noise problem.

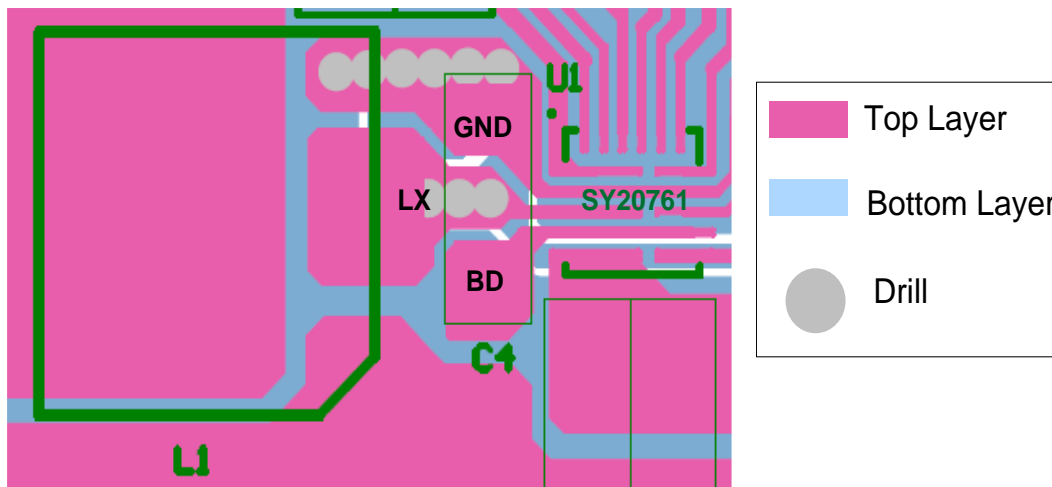
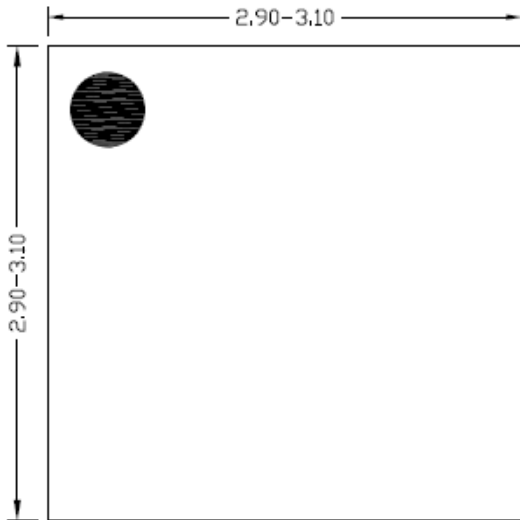
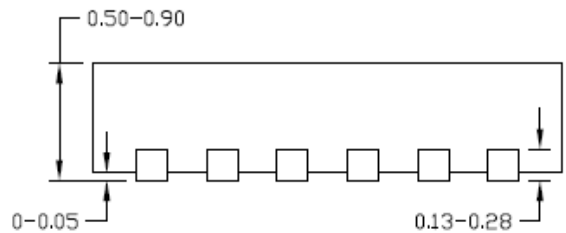

Figure2. PCB Layout Suggestion

QFN3×3-16 Package Outline Drawing



Top View



Side View

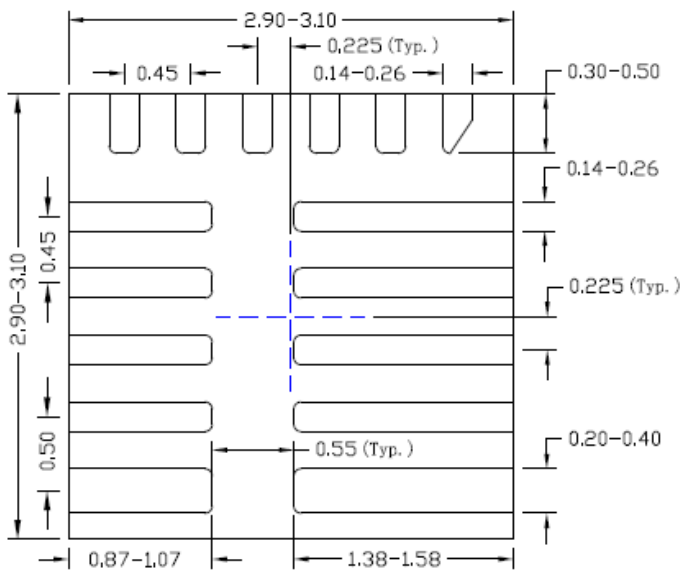

Bottom View

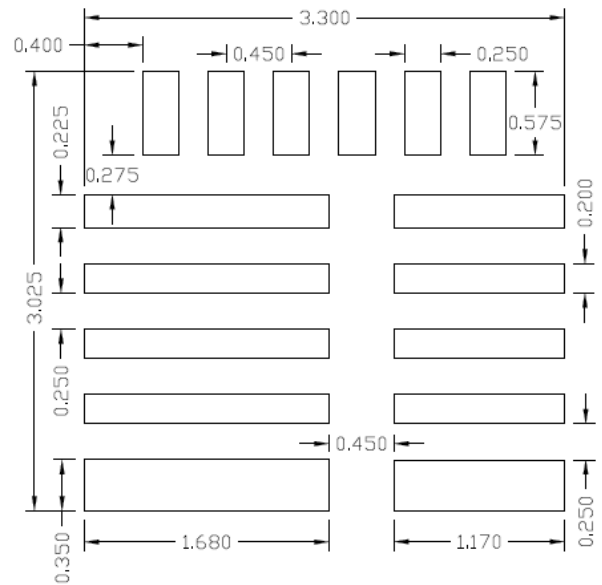

**Recommended PCB layout
(Reference only)**

Notes: All dimension in millimeter and exclude mold flash & metal burr.

Taping & Reel Specification

1. Taping orientation

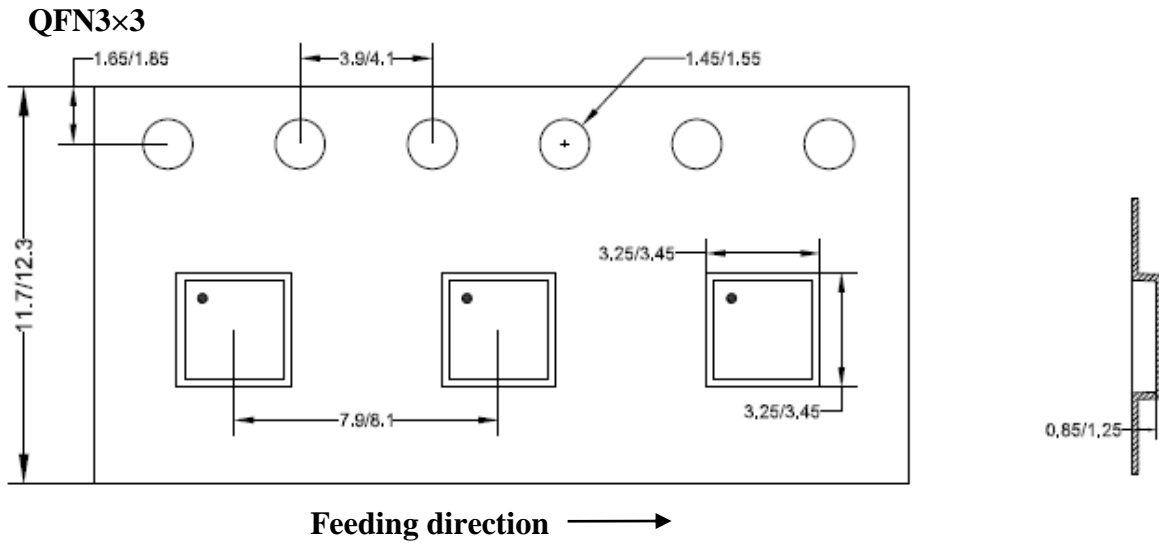

2. Carrier Tape & Reel specification for packages

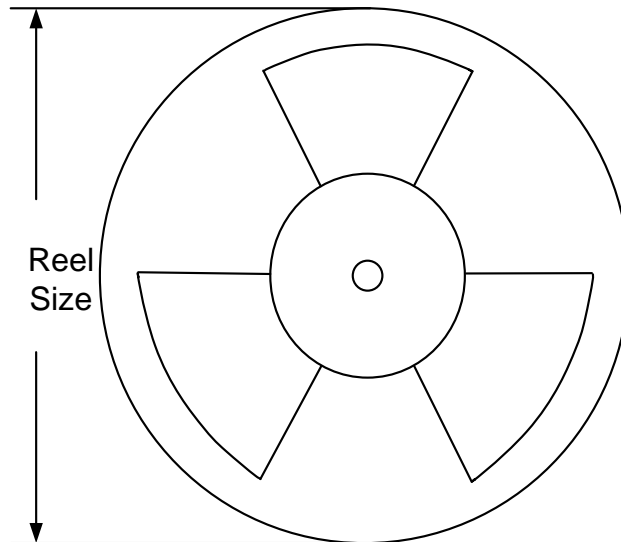

Package type	Tape width (mm)	Pocket pitch(mm)	Reel size (Inch)	Trailer length(mm)	Leader length (mm)	Qty per reel
QFN3x3	12	8	13"	400	400	5000

3. Others: NA



IMPORTANT NOTICE

- 1. Right to make changes.** Silergy and its subsidiaries (hereafter Silergy) reserve the right to change any information published in this document, including but not limited to circuitry, specification and/or product design, manufacturing or descriptions, at any time and without notice. This document supersedes and replaces all information supplied prior to the publication hereof. Buyers should obtain the latest relevant information before placing orders and should verify that such information is current and complete. All semiconductor products are sold subject to Silergy's standard terms and conditions of sale.
- 2. Applications.** Application examples that are described herein for any of these products are for illustrative purposes only. Silergy makes no representation or warranty that such applications will be suitable for the specified use without further testing or modification. Buyers are responsible for the design and operation of their applications and products using Silergy products. Silergy or its subsidiaries assume no liability for any application assistance or designs of customer products. It is customer's sole responsibility to determine whether the Silergy product is suitable and fit for the customer's applications and products planned. To minimize the risks associated with customer's products and applications, customer should provide adequate design and operating safeguards. Customer represents and agrees that it has all the necessary expertise to create and implement safeguards which anticipate dangerous consequences of failures, monitor failures and their consequences, lessen the likelihood of failures that might cause harm and take appropriate remedial actions. Silergy assumes no liability related to any default, damage, costs or problem in the customer's applications or products, or the application or use by customer's third-party buyers. Customer will fully indemnify Silergy, its subsidiaries, and their representatives against any damages arising out of the use of any Silergy components in safety-critical applications. It is also buyers' sole responsibility to warrant and guarantee that any intellectual property rights of a third party are not infringed upon when integrating Silergy products into any application. Silergy assumes no responsibility for any said applications or for any use of any circuitry other than circuitry entirely embodied in a Silergy product.
- 3. Limited warranty and liability.** Information furnished by Silergy in this document is believed to be accurate and reliable. However, Silergy makes no representation or warranty, expressed or implied, as to the accuracy or completeness of such information and shall have no liability for the consequences of use of such information. In no event shall Silergy be liable for any indirect, incidental, punitive, special or consequential damages, including but not limited to lost profits, lost savings, business interruption, costs related to the removal or replacement of any products or rework charges, whether or not such damages are based on tort or negligence, warranty, breach of contract or any other legal theory. Notwithstanding any damages that customer might incur for any reason whatsoever, Silergy's aggregate and cumulative liability towards customer for the products described herein shall be limited in accordance with the Standard Terms and Conditions of Sale of Silergy.
- 4. Suitability for use.** Customer acknowledges and agrees that it is solely responsible for compliance with all legal, regulatory and safety-related requirements concerning its products, and any use of Silergy components in its applications, notwithstanding any applications-related information or support that may be provided by Silergy. Silergy products are not designed, authorized or warranted to be suitable for use in life support, life-critical or safety-critical systems or equipment, nor in applications where failure or malfunction of an Silergy product can reasonably be expected to result in personal injury, death or severe property or environmental damage. Silergy assumes no liability for inclusion and/or use of Silergy products in such equipment or applications and therefore such inclusion and/or use is at the customer's own risk.
- 5. Terms and conditions of commercial sale.** Silergy products are sold subject to the standard terms and conditions of commercial sale, as published at <http://www.silergy.com/stdterms>, unless otherwise agreed in a valid written individual agreement specifically agreed to in writing by an authorized officer of Silergy. In case an individual agreement is concluded only the terms and conditions of the respective agreement shall apply. Silergy hereby expressly objects to and denies the application of any customer's general terms and conditions with regard to the purchase of Silergy products by the customer.
- 6. No offer to sell or license.** Nothing in this document may be interpreted or construed as an offer to sell products that is open for acceptance or the grant, conveyance or implication of any license under any copyrights, patents or other industrial or intellectual property rights. Silergy makes no representation or warranty that any license, either express or implied, is granted under any patent right, copyright, mask work right, or other intellectual property right. Information published by Silergy regarding third-party products or services does not constitute a license to use such products or services or a warranty or endorsement thereof. Use of such information may require a license from a third party under the patents or other intellectual property of the third party, or a license from Silergy under the patents or other intellectual property of Silergy.

For more information, please visit: www.silergy.com

© 2018 Silergy Corp.

All Rights Reserved.