



SY20762F

High Efficiency, 2A, Two-Cell Boost Li-Ion Battery Charger



General Description

SY20762F is a 3.0-5.5V_{IN}, 2A two-cell synchronous boost Li-Ion battery charger integrates 1MHz switching frequency and full protection functions. The charge current up to 2A can be programmed by using the external resistor for different portable applications and indicates the charger current information simultaneous. It has adaptive input current limit with selectable threshold for safety battery charge operation. SY20762F can disconnect output when there is output short circuit or shutdown happens. It consists of 18V rating FETs with extremely low ON resistance to achieve high charge efficiency and simple peripheral circuit design.

SY20762F along with small QFN3x3 footprint provides small PCB area application.

Ordering Information

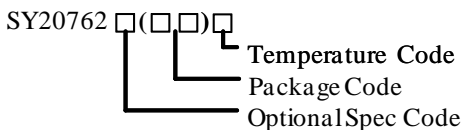

Ordering Number	Package type	Note
SY20762FQDC	QFN3x3-16	

Features

- Low Profile QFN3x3 Package
- Integrated Synchronous Boost with 18V Rating Low R_{DS(on)} FETs for High Charge Efficiency
- Trickle Current / Constant Current / Constant Voltage Charge Mode
- Adaptive Input Current Limit with selectable threshold
- Maximum 2A Constant Charge Current
- Charge Current Information Indication
- Programmable Constant Charge Current
- Programmable Charge Termination Current
- Thermal Regulation Protection
- External Shutdown Function
- Input Voltage UVLO and OVP
- Output Short Circuit Protection
- Over Temperature Protection
- Input Power Good Indication
- Battery Inserted Indication
- Charge Status Indication
- Normal Synchronous Boost Operation When Battery Removed

Applications

- POS, Cellular Telephones, PDA, MP3 Players, MP4 Players
- Digital Cameras
- Bluetooth Applications
- PSP Game Players, NDS Game Players

Typical Applications

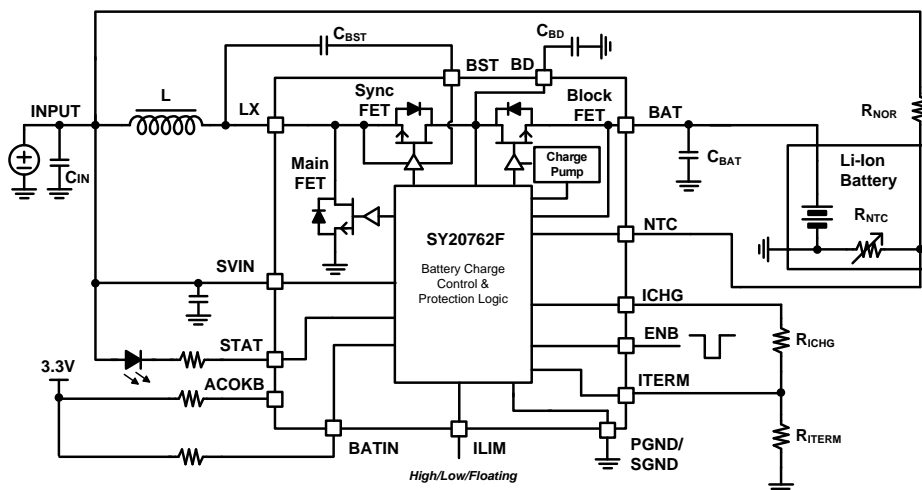
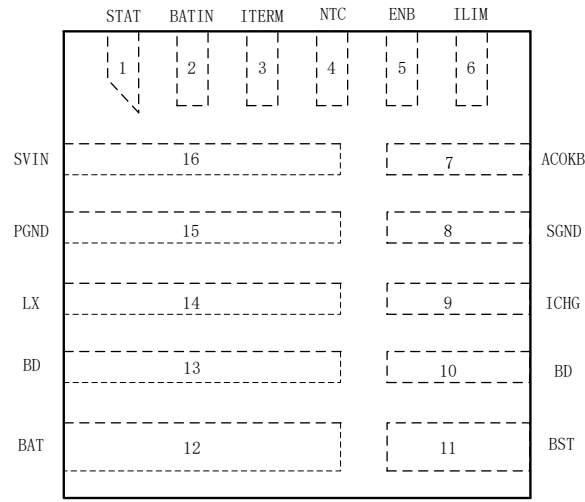

Figure1. Schematic Diagram

Pinout (top view)



(QFN3x3-16)

Top Mark: **AVX**xyz, (Device code: AVX, x=year code, y=week code, z=lot number code)

Name	Pin Number	Description
STAT	1	Charge status indication pin. It is open drain output pin and pulls high to SVIN thru a LED to indicate the charge in process. When the charge is done, LED is off.
BATIN	2	Battery inserted indication. Open drain output. Only can be pulled up to a lower than 3.6V power rail. Pull low if the battery is removed.
ITERM	3	Charge termination current program pin. $I_{TERM}=0.1 \cdot I_{CC} \cdot (1+R_{ICHG}/R_{ITERM})$
NTC	4	Thermal protection pin. UTP threshold is typical 75% V_{SVIN} and OTP threshold is typical 25% V_{SVIN} . Pull up to SVIN can disable charge logic and make the IC operate as normal boost regulator. Pull down to ground can shut down the IC.
ENB	5	Enable control pin. High logic to disable charger, and low logic to enable charger.
ILIM	6	Adaptive input current limit setting pin. Select the permitted maximum input voltage drop to trigger the input current limit function. Pull high for 500mV voltage drop, pull low for 375mV, floating for 250mV.
ACOKB	7	Input power good indication. Open drain output. Pull up to SVIN thru a LED to indicate if input is OK. Pull low if the adapter or USB input is present.
SGND	8	Signal ground pin.
ICHG	9	Charge current program pin. Pull down to GND with a resistor R_{ICHG} . The mirror current about 1/10000 of the blocking FET current will dump into the external resistor thru ICHG pin and compared to the internal reference 1V. So $I_{CC}=[1V/(R_{ICHG}+R_{ITERM})] \times 10000$, $I_{TC}=[1V/R_{ICHG}+R_{ITERM}] \times 1000$.
BD	10,13	Connect to the Drain of internal Blocking FET. Bypass at least 4.7uF ceramic cap to GND.
BST	11	Boot-Strap pin. Supply Rectified FET's gate driver. Decouple this pin to LX with 0.1uF ceramic cap.
BAT	12	Battery positive pin.
LX	14	Switch node pin. Connect to external inductor.
PGND	15	Power ground pin.
SVIN	16	Analog power input pin. Connect a MLCC from this pin to ground to decouple high harmonic noise. This pin has OVP and UVLO function to make the charger operate within safe input voltage area.



Absolute Maximum Ratings

SVIN, BAT, LX, NTC, STAT, ACOKB, BD, ENB, ICHG, ILIM	18V
BATIN, ITERM	4V
BST-LX Voltage	4V
LX Pin current continuous	5A
Power Dissipation, P_D @ $T_A = 25^\circ\text{C}$, QFN3X3	2.6W
Package Thermal Resistance	
θ_{JA}	38°C/W
θ_{JC}	4°C/W
Junction Temperature Range	-40°C to +125°C
Lead Temperature (Soldering, 10 sec.)	260°C
Storage Temperature Range	-65°C to 150°C

Recommended Operating Conditions

SVIN, NTC	3V to 5.5V
BAT, LX, STAT, ACOKB, BD, ENB, ILIM	-0.3V to 16V
BATIN, ITERM	-0.3V to 3.6V
LX Pin current continuous	5A
Junction Temperature Range	-40°C to 125°C
Ambient Temperature Range	-40°C to 85°C



Electrical Characteristics

T_A=25°C, V_{IN}=5V, GND=0V, C_{IN}=4.7uF, L=0.68uH, R_{ICHG}=0, R_{ITERM}=10kΩ, unless otherwise specified.

Symbol	Parameter	Conditions	Min	Typ	Max	Unit
Bias Supply (V_{SVIN})						
V _{SVIN}	Supply voltage		3		16	V
V _{UVLO}	V _{SVIN} under voltage lockout threshold	V _{SVIN} rising and measured from V _{SVIN} to GND			2.9	V
ΔV _{UVLO}	V _{SVIN} under voltage lockout hysteresis	Measured from V _{SVIN} to GND		100		mV
V _{OVP}	Input overvoltage protection	V _{SVIN} rising and measured from V _{SVIN} to GND	5.8			V
ΔV _{OVP}	Input overvoltage protection hysteresis	Measured from V _{SVIN} to GND		0.5		V
Quiescent Current						
I _{BAT}	Battery discharge current	Shutdown IC			25	uA
I _{IN}	Input quiescent current	Disable Charge			1.5	mA
Oscillator and PWM						
f _{SW}	Switching frequency			1000		kHz
T _{MINOFF}	Main N-FET minimum off time	With 18V rating		100		ns
T _{MAXOFF}	Main N-FET maximum off time	With 18V rating		30		us
T _{MINON}	Main N-FET minimum on time	With 18V rating		100		ns
Power MOSFET						
R _{NFET_M}	R _{DS(ON)} of Main N-FET			80		mΩ
R _{NFET_R}	R _{DS(ON)} of Rectified N-FET			40		mΩ
R _{NFET_B}	R _{DS(ON)} of Blocking N-FET			40		mΩ
Voltage Regulation						
V _{CV}	2-Cell CV charge mode voltage		8.32	8.40	8.48	V
ΔV _{RCH}	2-Cell Recharge Voltage		100	200	300	mV
V _{TRK}	2-cell TC charge mode battery voltage threshold	V _{BAT} rising edge threshold	5.4	5.6	5.8	V
Battery Connect Detection						
V _{DET}	NTC voltage threshold for Battery detect	NTC Falling Edge	85%		95%	V _{SVIN}
t _{DET}	Detect delay time			260		ms
Charge Current						
	Internal charge current accuracy for Constant Current Mode	I _{CC} =1000mA	-10%		10%	
	Internal charge current accuracy for Trickle Current Mode	I _{TC} =100mA	-50%		50%	
Output Voltage OVP						
V _{OVP}	Output voltage OVP threshold		105%	110%	115%	V _{CV}
Input Current Limit						
V _{DISS}	Vin drop for slow CC REF discharge Voltage Threshold	Float ILIM		250		mV
		Pull low ILIM		375		
		Pull high ILIM		500		
ΔV _{DISS}	Slow Discharge Voltage Hysteresis	Positive edge		50		mV
V _{DISF}	Vin drop for fast CC REF discharge Voltage Threshold	Float ILIM		500		mV
		Pull low ILIM		750		
		Pull high ILIM		1000		
ΔV _{DISF}	Fast Discharge Voltage Hysteresis			50		mV
Termination Current						



I _{TERM}	Termination current threshold	R _{ICHG} =0,R _{ITERM} =10k		10%		I _{CC}
		R _{ICHG} =5k,R _{ITERM} =5k		20%		
		R _{ICHG} =7.5k,R _{ITERM} =2.5k		40%		
Timer						
T _{MC}	Charge mode change delay time			30		ms
T _{TERM}	Termination delay time			30		ms
t _{rch_deg}	Recharge deglitch time			15		s
Short Circuit Protection						
V _{SHORT}	Output short protection threshold		1.70	2.00	2.30	V
Linear charger Mode						
I _{LCHG}	Battery Charger current when the blocking FET is in linear mode	V _{BAT} <V _{SHORT}		5%		I _{CC}
I _{LPEAK}	Peak linear current when Battery is absent			1		A
V _{BD}	Bus voltage regulation		5.8	6	6.2	V
V _{TRON}	Blocking FET fully turn on threshold V _{TRON} =V _{BAT} -V _{IN}	V _{BAT} > V _{TRK}		100		mV
Enable ON/OFF Control						
V _{ENH}	High level logic for enable off		1.5			V
V _{ENL}	Low level logic for enable on				0.4	V
Battery Thermal Protection NTC						
UTP	Under temperature protection		70%	75%	80%	V _{SVIN}
	Under temperature protection hysteresis	Falling edge		5%		
OTP	Over temperature protection		28%	30%	32%	
	Over temperature protection hysteresis	Rising edge		2%		
Thermal Regulation And Thermal shutdown						
T _{REG}	Thermal regulation threshold			120		°C
T _{REGHYS}	Thermal regulation hysteresis falling edge			20		°C
	Thermal regulation fold back ratio			0.25		I _{CC}
T _{SD}	Thermal shutdown temperature	Rising Threshold		160		°C
T _{SDHYS}	Thermal shutdown temperature hysteresis			30		°C

Note 1: Stresses beyond the “Absolute Maximum Ratings” may cause permanent damage to the device. These are stress ratings only. Functional operation of the device at these or any other conditions beyond those indicated in the operational sections of the specification is not implied. Exposure to absolute maximum rating conditions for extended periods may affect device reliability.

Note 2: θ_{JA} is measured in the natural convection at T_A = 25°C on a low effective four-layer thermal conductivity test board of JEDEC 51-3 thermal measurement standard.

Note 3: The device is not guaranteed to function outside its operating conditions

General Function Description

SY20762F is a 3.0-5.5V_{IN}, 2A two-cell synchronous boost Li-Ion battery charger integrates 1MHz switching frequency and full protection functions. The charge current up to 2A can be programmed by using the external resistor for different portable applications and indicates the charger current information simultaneous. It has adaptive input current limit with selectable threshold for safety battery charge operation. SY20762F can disconnect output when there is output short circuit or shutdown happens. It consists of 18V rating FETs with extremely low ON resistance to achieve high charge efficiency and simple peripheral circuit design.

Charging Status Indication Description

1. Charge-In-Process – Pull and keep STAT pin to Low;
2. Charge Done – Pull and keep STAT pin to High;
3. Fault Mode – Output high and low voltage alternatively with 1.3Hz frequency. Connect a LED from SVIN to STAT pin, LED ON means Charge-in-Process, LED OFF means Charge Done, LED Flashing with 1.3Hz means Fault Mode.

STAT pin will be open internally if the adapter is absent.

Input and Battery Indication Description

SY20762F has input and battery detecting functions. If the input is present, the ACOKB will be pulled down. Same, the device can judge if the battery pack is inserted based on the NTC pin voltage. If the battery is present, BATIN can be pulled high thru the pull-up resistor.

ACOKB and BATIN detection always work if the adapter is present, regardless of the ENB level.

ACOKB and BATIN pins will be open internally if the adapter is absent.

Switching Mode Boost Charger Basic Operation Description

Switching Mode Control Strategy

SY20762F is a switching mode Boost charger for the applications with USB power input. SY20762F utilizes quasi-fixed frequency constant OFF time control to simplify the internal close-loop compensation design. Slope compensation is not necessary for the stable operation. The quasi-fixed frequency settled at 1MHz is easy for the size minimization of peripheral circuit design. During the light load operation, the OFF time is going to be stretched to achieve frequency fold back.

Operation Principle

SY20762F can normally work with or without Li-Ion battery both.

Battery Present

Before SY20762F start-up, C_{BD} is charged by the battery thru the body diode of blocking FET, and V_{BD} equals to V_{BAT}.

If the plug in input voltage V_{IN} is higher than V_{BD}=V_{BAT}, C_{BD} is charged by V_{IN} further thru the body diode of sync-FET. Under this condition, the Boost charger operates in light load mode and regulates the V_{BD} at 6V and the blocking FET works in linear charge mode. If the V_{BAT} is lower than the internal short circuit threshold V_{SHORT}, the linear charge current is 1/20 I_{CC}. When V_{BAT} is higher than V_{SHORT} but lower than the threshold of trickle charge, the linear charge current is 1/10 of I_{CC}. Note that, charging current would not be increased to I_{CC} when the block FET operates in linear mode. With the increasing of V_{BAT}, when V_{BAT} is higher than both V_{IN} and V_{TRK} the blocking FET is fully turned on and the switching mode boost charger takes over the battery charging. The current in the blocking FET is mirrored to be as the charging current I_{CHG}. If V_{IN} is lower than V_{BD}=V_{BAT} at the plug in time, the switching mode boost charger starts work directly.

During the charging mode, constant (trickle) charging current loop is active first. When V_{BAT} equals to constant voltage threshold V_{CV}, constant voltage loop takes over and pull down the charging current. When I_{CHG} is lower than the termination current threshold I_{TERM}, the main FET of boost charger is turned off firstly. Sync-FET and blocking FETs are turned off together when the current is down to zero. Then, SY20762F is waiting for recharge mode.

Battery Absent

If there's no battery connection detected thru NTC pin, SY20762F operates as a normal switching mode boost converter. When V_{SVIN} is higher than UVLO threshold, the blocking FET is softly turned on. After the blocking FET fully turn-on, switching mode boost converter starts work. The internal current loop and voltage loop are active both.

Basic Protection Principle

SY20762F has fully battery charging protection. When the input over voltage protection, the output over voltage protection or the thermal protection happens, the main FET of the boost charger is turned off immediately. The sync-FET and the blocking FET are

turned off later when the current is down to zero. When the V_{BAT} is lower than V_{SHORT} , the short circuit protection happens. The main FET is turned off firstly. The block FET enters linear mode with $1/20 I_{CC}$ charging current. When V_{BAT} recovers back to be higher than V_{SHORT} , the boost charger restarts to work at light load and regulates V_{BD} at 6V. The linear charge current is increased from $1/20 I_{CC}$ to trickle current.

Basic Adaptive Input Current Limit Principle

SY20762F has adaptive input current limit function. Before the IC starts charging work, the input voltage is detected and saved as reference V_{INREF} . Once IC starts to charge, the output charging current I_{CHG} is ramped up softly and the V_{SVIN} drop is monitored

simultaneously. When the input voltage drop is larger than V_{DISS} the output charging current reference I_{CHGREF} starts to be discharged slowly and when the voltage drop is larger than V_{DISF} the I_{CHGREF} starts to be fast discharged. With the discharging of I_{CHGREF} , the charging current is decreased and the V_{SVIN} would recover back. Once the V_{SVIN} recovers back into the normal range, the I_{CHGREF} is kept on the current value. The I_{CHGREF} would be decreased along with the increasing of output voltage to keep the input power at the maximum value. The internal digital machine state is built up to achieve this function.

Typical Performance Characteristics

$T_A=25^{\circ}\text{C}$, $V_{IN}=5\text{V}$, $L=0.68\mu\text{H}$, $R_{\text{CHG}}=0$, $R_{\text{ITERM}}=10\text{k}\Omega$, unless otherwise specified.

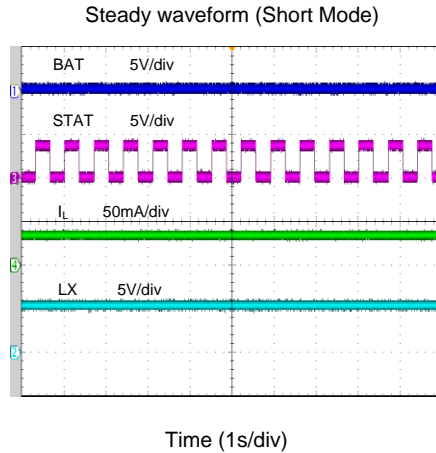
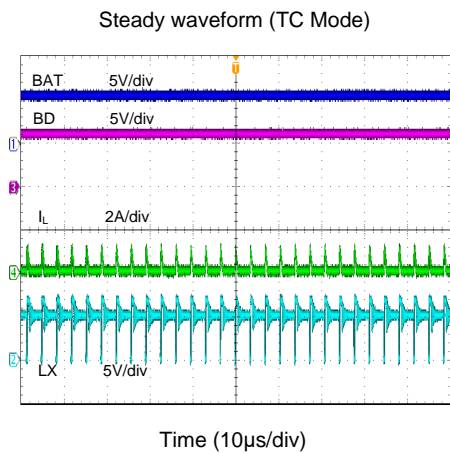
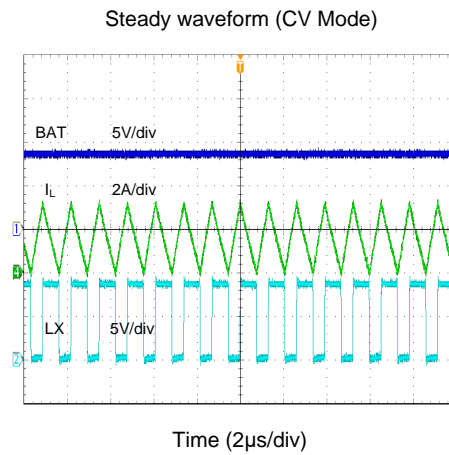
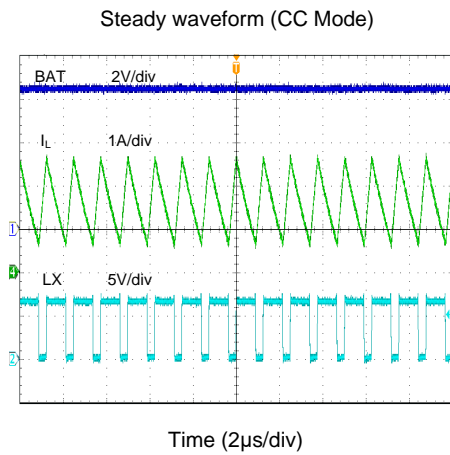
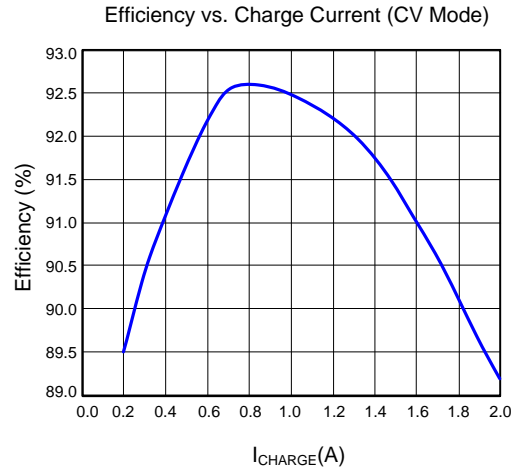
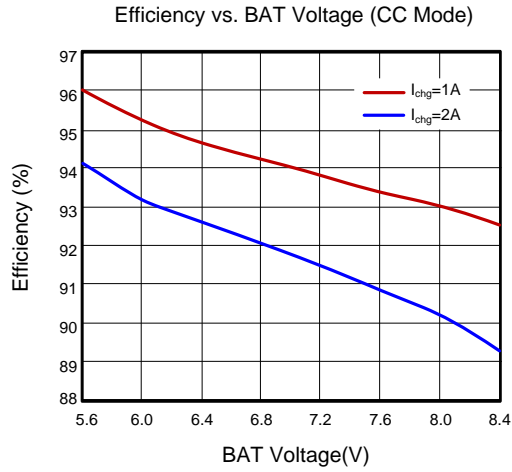

Power On (CC Mode)

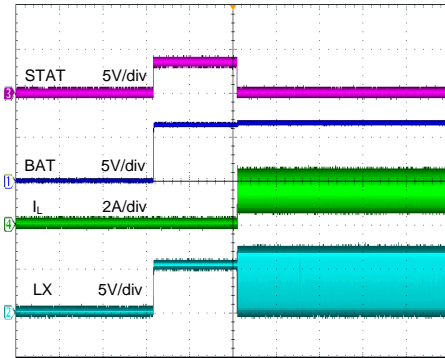

Time (400ms/div)

Power Off (CC Mode)

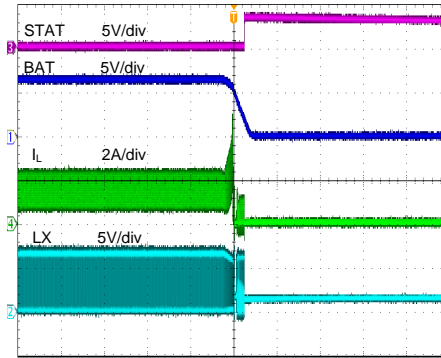

Time (2ms/div)

Power On (CV Mode)

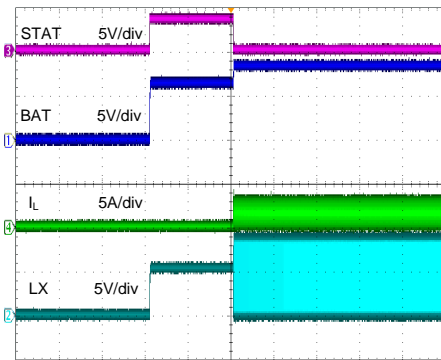

Time (400ms/div)

Power Off (CV Mode)

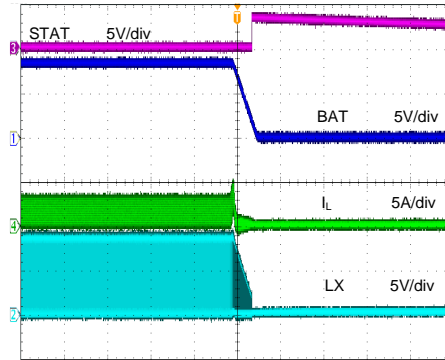

Time (4ms/div)

Adaptive Input Current Limit

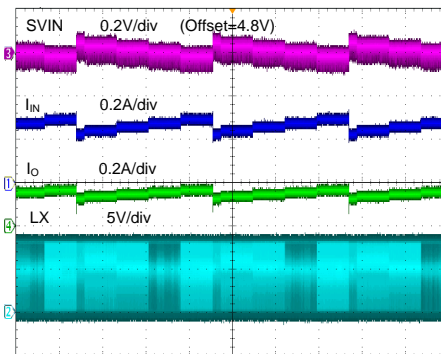

Time (4s/div)

Boost Mode (Null load)

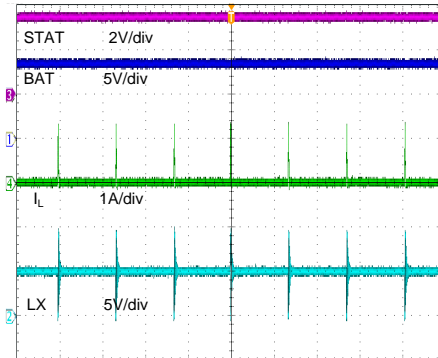

Time (20μs/div)

Input Indication

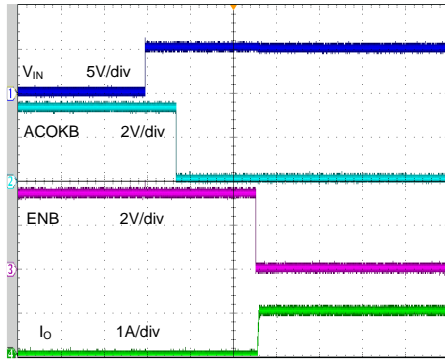

Time (1s/div)

Battery Indication

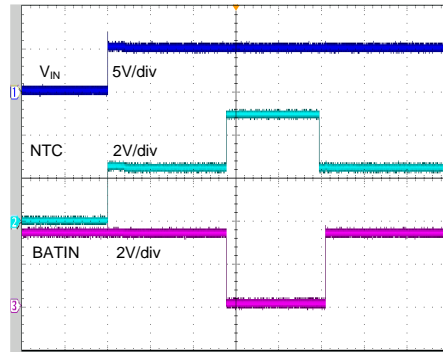

Time (2s/div)

Applications Information

Because of the high integration of SY20762F, the application circuit based on this regulator IC is rather simple. Only input capacitor C_{IN} , output capacitor C_{OUT} , inductor L , NTC resistors R_1 , R_2 need to be selected for the targeted applications specifications.

NTC resistor:

SY20762F monitors battery temperature by measuring the input voltage and NTC voltage. The controller triggers the UTP or OTP when the rate K ($K = V_{NTC}/V_{SVIN}$) reaches the threshold of UTP (K_{UT}) or OTP (K_{OT}). The temperature sensing network is showed as below.

Choose R_1 and R_2 to program the proper UTP and OTP points.

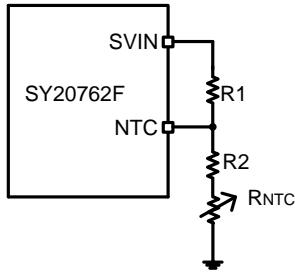

The calculation steps are:

1. Define K_{UT} , $K_{UT} = 70 \sim 80\%$
2. Define K_{OT} , $K_{OT} = 28 \sim 32\%$
3. Assume the resistance of the battery NTC thermistor is R_{UT} at UTP threshold and R_{OT} at OTP threshold.

4. Calculate R_2 ,

$$R_2 = \frac{K_{OT}(1 - K_{UT})R_{UT} - K_{UT}(1 - K_{OT})R_{OT}}{K_{UT} - K_{OT}}$$

5. Calculate R_1

$$R_1 = (1/K_{OT} - 1)(R_2 + R_{OT})$$

If choose the typical values $K_{UT} = 75\%$ and $K_{OT} = 30\%$, then

$$R_2 = 0.17R_{UT} - 1.17R_{OT}$$

$$R_1 = 2.3(R_2 + R_{OT})$$

Input capacitor C_{IN} :

The ripple current through input capacitor is greater than

$$I_{CIN_RMS} = \frac{V_{IN} * (V_{OUT} - V_{IN})}{2\sqrt{3} * L * F_{SW} * V_{OUT}}$$

X5R or X7R ceramic capacitors with greater than 4.7uF capacitance are recommended to handle this ripple current.

Output capacitor C_{OUT} :

The output capacitor is selected to handle the output ripple noise requirements. This ripple voltage is related to the capacitance and its equivalent series resistance (ESR). For the best performance, it is recommended to use X5R or better grade low ESR ceramic capacitor. The voltage rating of the output capacitor should be higher than the maximum output voltage. The minimum required capacitance can be calculated as:

$$C_{OUT} = \frac{I_{CC} * (V_{OUT} - V_{IN})}{F_{SW} * V_{OUT} * V_{RIPPLE}}$$

V_{RIPPLE} is the peak to peak output ripple, I_{CC} is the setting charge current.

For SY20762F, output capacitor is paralleled by C_{BD} and C_{BAT} , for smaller output ripple noise, each capacitor with greater than 10uF capacitance is recommended.

Inductor L :

There are several considerations in choosing this inductor.

- 1) Choose the inductance to provide the desired ripple current. It is suggested to choose the ripple current to be about 40% of the average input current. The inductance is calculated as:

$$L = \left(\frac{V_{IN}}{V_{OUT}} \right)^2 \frac{(V_{OUT} - V_{IN})}{I_{CC} * F_{SW} * 40\%}$$

Where F_{SW} is the switching frequency and I_{CC} is the setting charge current.

The SY20762F is quite tolerant of different ripple current amplitude. Consequently, the final choice of inductance can be slightly off the calculation value without significantly impacting the performance.

- 2) The saturation current rating of the inductor must be selected to be greater than the peak inductor current under full load conditions.

$$I_{SAT,MIN} > \left(\frac{V_{OUT}}{V_{IN}} \right) * I_{CC} + \left(\frac{V_{IN}}{V_{OUT}} \right) * \frac{(V_{OUT} - V_{IN})}{2 * F_{SW} * L}$$

- 3) The DCR of the inductor and the core loss at the switching frequency must be low enough to achieve the desired efficiency requirement. It is desirable to choose an inductor with $DCR < 10\text{mohm}$ to achieve a good overall efficiency.

Layout Design:

The layout design of SY20762F regulator is relatively simple. For the best efficiency and minimum noise problems, we should place the following components close to the IC: C_{SVIN} , L, C_{BD} .

- 1) The loop of main MOSFET, rectifier diode, and C_{BD} must be as short as possible

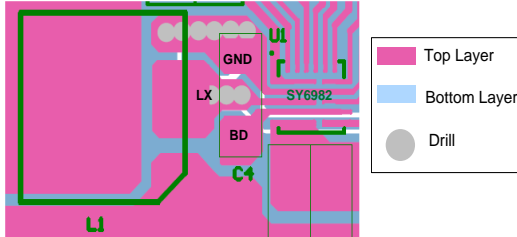

- 2) It is desirable to maximize the PCB copper area connecting to GND pin to achieve the best thermal and noise performance.

- 3) C_{SVIN} must be close to pin SVIN and GND.

- 4) The PCB copper area associated with LX pin must be minimized to avoid the potential noise problem.

- 5) The small signal component R_{ICHG} must be placed close to IC and must not be adjacent to the LX net on the PCB layout to avoid the noise problem

QFN3×3-16 Package Outline Drawing

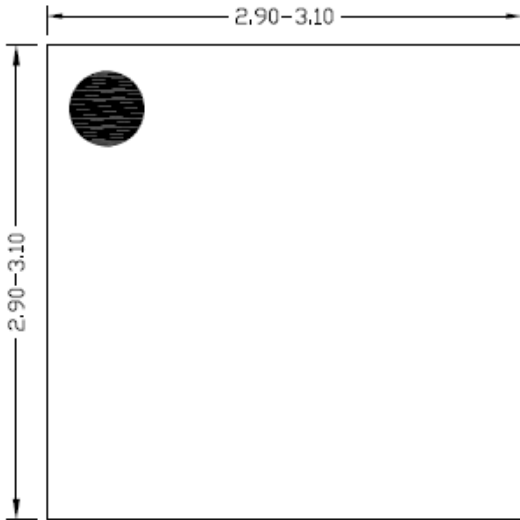

Top View

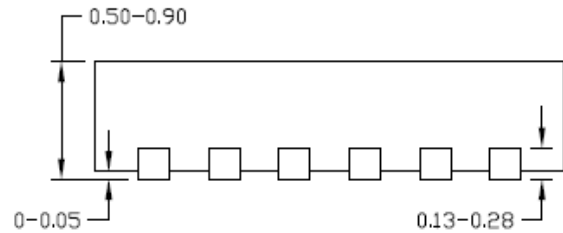

Side View

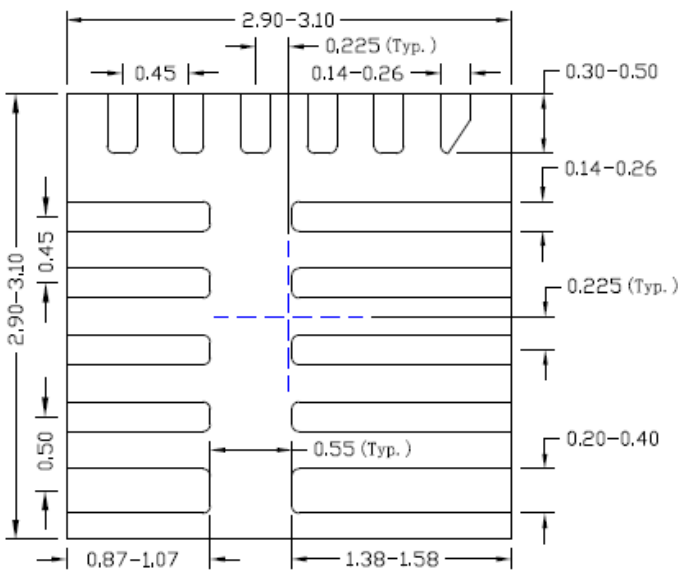

Bottom View

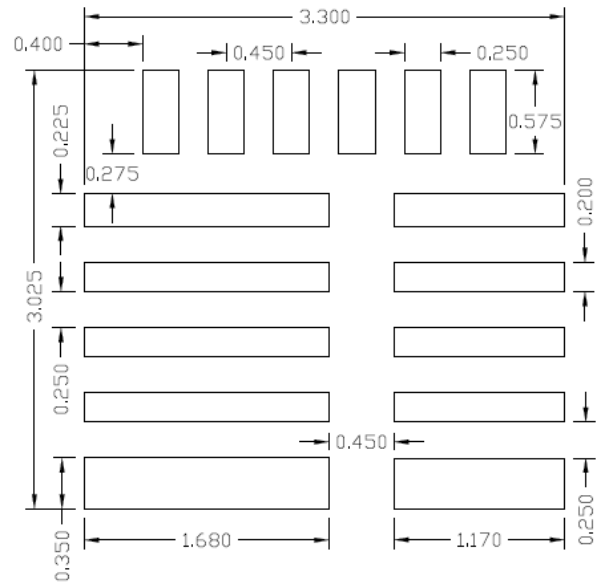

**Recommended PCB layout
(Reference only)**

Notes: All dimension in millimeter and exclude mold flash & metal burr

Taping & Reel Specification

1. Taping orientation

QFN3x3

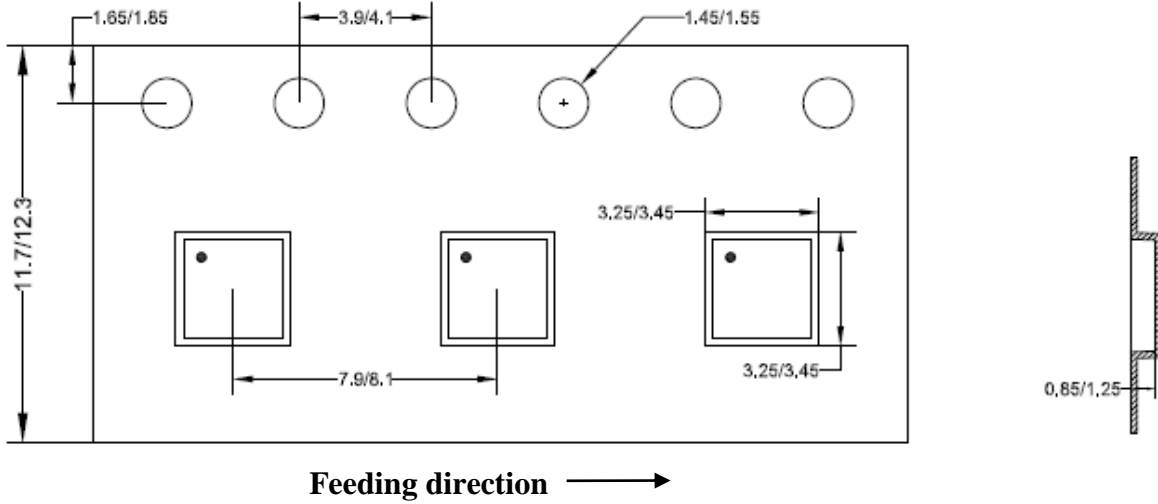

2. Carrier Tape & Reel specification for packages

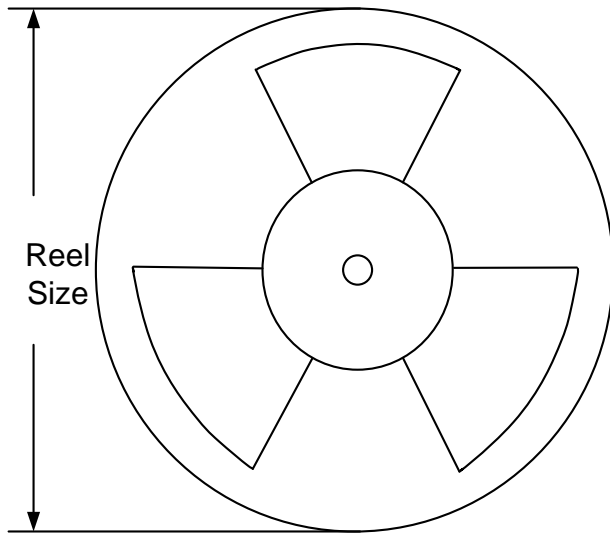

Package types	Tape width (mm)	Pocket pitch(mm)	Reel size (Inch)	Trailer length(mm)	Leader length (mm)	Qty per reel
QFN3x3	12	8	13"	400	400	5000

3. Others: NA



IMPORTANT NOTICE

- 1. Right to make changes.** Silergy and its subsidiaries (hereafter Silergy) reserve the right to change any information published in this document, including but not limited to circuitry, specification and/or product design, manufacturing or descriptions, at any time and without notice. This document supersedes and replaces all information supplied prior to the publication hereof. Buyers should obtain the latest relevant information before placing orders and should verify that such information is current and complete. All semiconductor products are sold subject to Silergy's standard terms and conditions of sale.
- 2. Applications.** Application examples that are described herein for any of these products are for illustrative purposes only. Silergy makes no representation or warranty that such applications will be suitable for the specified use without further testing or modification. Buyers are responsible for the design and operation of their applications and products using Silergy products. Silergy or its subsidiaries assume no liability for any application assistance or designs of customer products. It is customer's sole responsibility to determine whether the Silergy product is suitable and fit for the customer's applications and products planned. To minimize the risks associated with customer's products and applications, customer should provide adequate design and operating safeguards. Customer represents and agrees that it has all the necessary expertise to create and implement safeguards which anticipate dangerous consequences of failures, monitor failures and their consequences, lessen the likelihood of failures that might cause harm and take appropriate remedial actions. Silergy assumes no liability related to any default, damage, costs or problem in the customer's applications or products, or the application or use by customer's third-party buyers. Customer will fully indemnify Silergy, its subsidiaries, and their representatives against any damages arising out of the use of any Silergy components in safety-critical applications. It is also buyers' sole responsibility to warrant and guarantee that any intellectual property rights of a third party are not infringed upon when integrating Silergy products into any application. Silergy assumes no responsibility for any said applications or for any use of any circuitry other than circuitry entirely embodied in a Silergy product.
- 3. Limited warranty and liability.** Information furnished by Silergy in this document is believed to be accurate and reliable. However, Silergy makes no representation or warranty, expressed or implied, as to the accuracy or completeness of such information and shall have no liability for the consequences of use of such information. In no event shall Silergy be liable for any indirect, incidental, punitive, special or consequential damages, including but not limited to lost profits, lost savings, business interruption, costs related to the removal or replacement of any products or rework charges, whether or not such damages are based on tort or negligence, warranty, breach of contract or any other legal theory. Notwithstanding any damages that customer might incur for any reason whatsoever, Silergy' aggregate and cumulative liability towards customer for the products described herein shall be limited in accordance with the Standard Terms and Conditions of Sale of Silergy.
- 4. Suitability for use.** Customer acknowledges and agrees that it is solely responsible for compliance with all legal, regulatory and safety-related requirements concerning its products, and any use of Silergy components in its applications, notwithstanding any applications-related information or support that may be provided by Silergy. Silergy products are not designed, authorized or warranted to be suitable for use in life support, life-critical or safety-critical systems or equipment, nor in applications where failure or malfunction of an Silergy product can reasonably be expected to result in personal injury, death or severe property or environmental damage. Silergy assumes no liability for inclusion and/or use of Silergy products in such equipment or applications and therefore such inclusion and/or use is at the customer's own risk.
- 5. Terms and conditions of commercial sale.** Silergy products are sold subject to the standard terms and conditions of commercial sale, as published at <http://www.silergy.com/stdterms>, unless otherwise agreed in a valid written individual agreement specifically agreed to in writing by an authorized officer of Silergy. In case an individual agreement is concluded only the terms and conditions of the respective agreement shall apply. Silergy hereby expressly objects to and denies the application of any customer's general terms and conditions with regard to the purchase of Silergy products by the customer.
- 6. No offer to sell or license.** Nothing in this document may be interpreted or construed as an offer to sell products that is open for acceptance or the grant, conveyance or implication of any license under any copyrights, patents or other industrial or intellectual property rights. Silergy makes no representation or warranty that any license, either express or implied, is granted under any patent right, copyright, mask work right, or other intellectual property right. Information published by Silergy regarding third-party products or services does not constitute a license to use such products or services or a warranty or endorsement thereof. Use of such information may require a license from a third party under the patents or other intellectual property of the third party, or a license from Silergy under the patents or other intellectual property of Silergy.

For more information, please visit: www.silergy.com

© 2019 Silergy Corp.

All Rights Reserved.