

General Description

The SY5882N is a single stage Flyback and PFC controller targeting at LED Dimming applications, which can achieve up to 2% dimming level and high precision for full loading range. It is a primary side controller without applying any secondary feedback circuit for low cost, and drives the converter in the quasi-resonant mode to achieve high efficiency. It keeps the converter in constant on time operation to achieve high power factor.

SY5882N has CV mode for fast startup, especially in deep dimming. CV function is also can be used as the power supply of low energy MCU.

Ordering Information

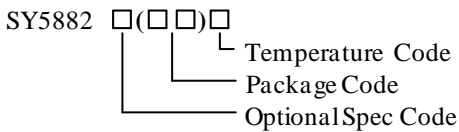

Ordering Number	Package type	Note
SY5882NFAC	SO8	----

Features

- 2.0%~100.0% Dimming Range
- CV Mode for Bias Supply when PWM=0.0%
- Primary Side Control Eliminates the Opto-coupler
- Valley Turn-on of the Primary MOSFET to Achieve Low Switching Losses
- 0.3V Primary Current Sense Reference Voltage Leads to A Lower Sense Resistance thus A Lower Conduction Loss
- 200mA Sourcing Current and 650mA Sinking Current Drive Capability
- Low Start up Current: 34μA Typical
- Reliable Short LED and Open LED Protection
- Power Factor >0.90 with Single-stage Conversion.(Analog Dimming Only)
- RoHS Compliant and Halogen Free
- Compact Package: SO8

Applications

- LED Lighting

Typical Applications

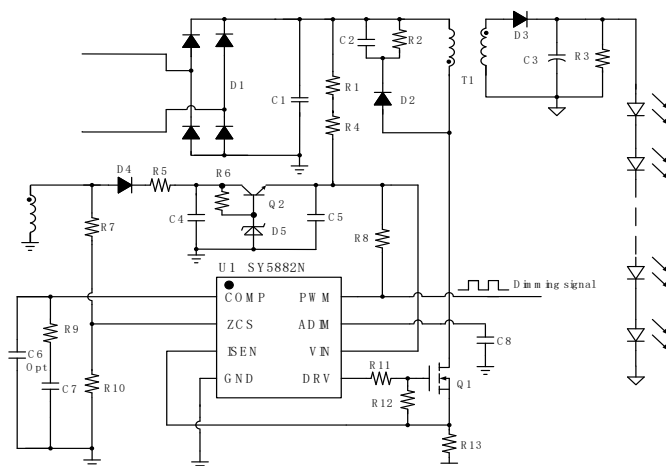

Figure 1a. Analog dimming with PWM signal input

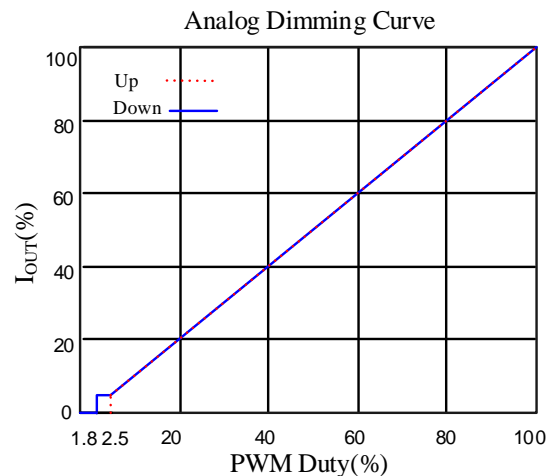

Figure 1b. Analog Dimming Curve

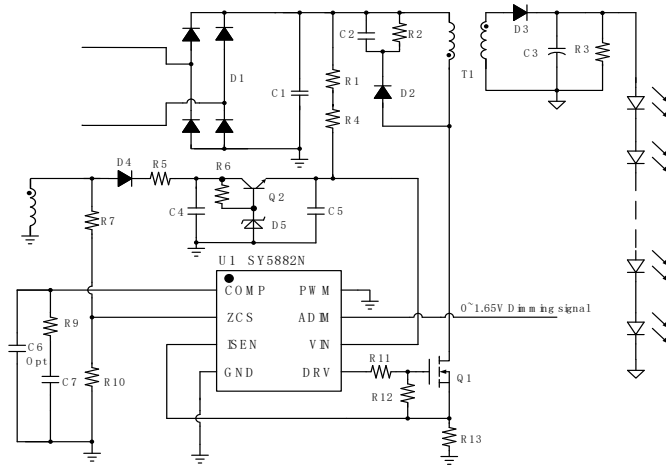

Figure 2a. Analog dimming with Analog signal input

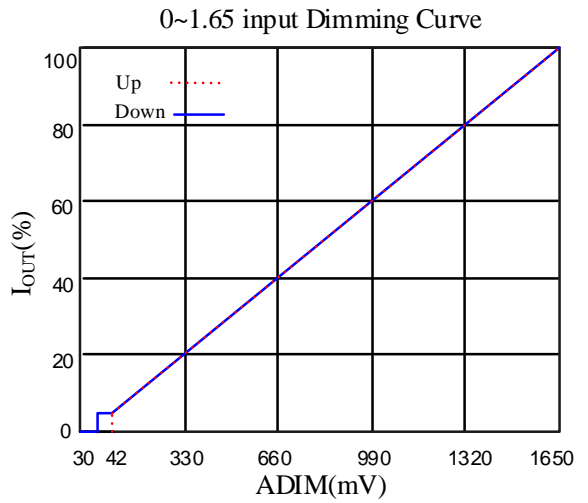

Figure 2b. Analog Dimming Curve

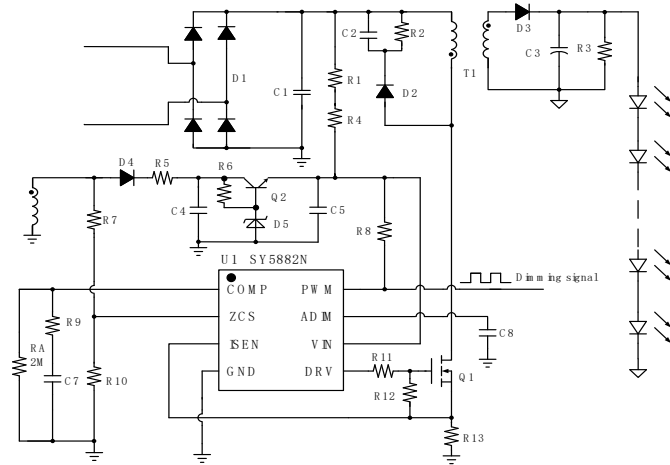
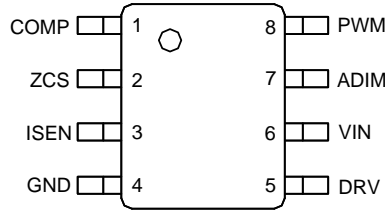

Figure 1c. Analog dimming for less than 2% dimming depth

Pinout (top view)



(SO8)

Top Mark: CNU xyz (device code: CNU, *x*=year code, *y*=week code, *z*= lot number code)

Pin Name	Pin number	Pin Description
COMP	1	Loop compensation pin. Connect a RC network across this pin and ground to stabilize the control loop.
ZCS	2	Inductor current zero-crossing detection pin. This pin receives the auxiliary winding voltage by a resistor divider and detects the inductor current zero crossing point. This pin also provides over voltage protection, line regulation modification function and CV detection simultaneously. If the voltage on this pin is above $V_{ZCS,OV}$, the IC would enter over voltage protection mode. Good line regulation can be achieved by adjusting the upper resistor of the divider.
ISEN	3	Current sense pin. Connect this pin to the source of the primary switch. Connect the sense resistor across the source of the primary switch and the GND pin. (current sense resistor R_s : $R_s = k \frac{V_{REF} \times N_{PS}}{I_{OUT}}$, $k=0.167$)
GND	4	Ground pin.
DRV	5	Gate driver pin. Connect this pin to the gate of primary MOSFET.
VIN	6	Power supply pin. This pin also provides output over voltage protection along with ZCS pin.
ADIM	7	Bypass this pin to GND with enough capacitance to hold on internal voltage reference.
PWM	8	PWM dimming input pin, this pin detects the PWM dimming signal.

Block Diagram

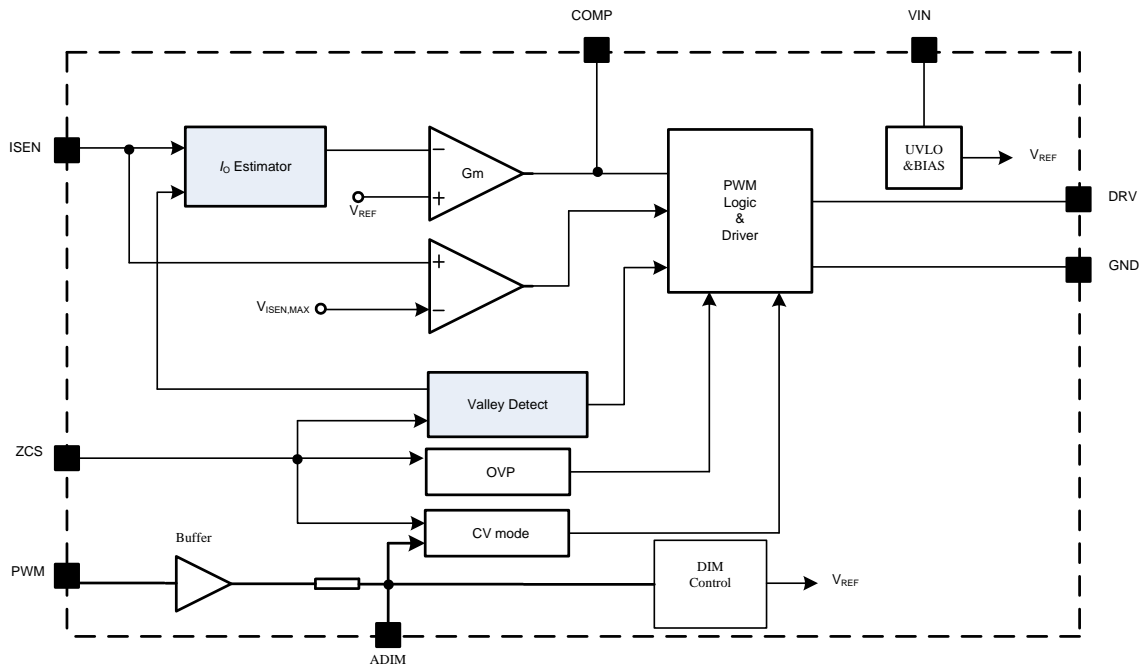

Figure.3 Block Diagram

Absolute Maximum Ratings (Note 1)

VIN, DRV	-----	-0.3V~26V
Supply Current I_{VIN}	-----	7mA
PWM	-----	-0.3V~23V
ADIM, ZCS	-----	-0.3V~1.8V
ISEN, COMP	-----	-0.3~ 3.6V
Power Dissipation, @ $T_A = 25^\circ\text{C}$ SO8	-----	1.1W
Package Thermal Resistance (Note 2)		
SO8, θ_{JA}	-----	88°C/W
SO8, θ_{JC}	-----	45°C/W
Junction Temperature Range	-----	-40°C to 150°C
Lead Temperature (Soldering, 10 sec.)	-----	260°C
Storage Temperature Range	-----	-65°C to 150°C

Recommended Operating Conditions (Note 3)

VIN, DRV	-----	8.5V~20V
----------	-------	----------

Electrical Characteristics

($V_{IN} = 12V$ (Note 3), $T_A = 25^\circ C$ unless otherwise specified)

Parameter	Symbol	Test Conditions	Min	Typ	Max	Unit
Power Supply Section						
Input Voltage Range	V_{VIN}		8.5		22	V
VIN Turn-on Threshold	V_{VIN_ON}		19.5	20.5	22	V
VIN Turn-off Threshold	V_{VIN_OFF}		6.7	7.3	8.0	V
VIN OVP Voltage	V_{VIN_OVP}			$V_{VIN_ON}+4$		V
Start up Current	I_{ST}	$V_{VIN} < V_{VIN_ON}$	24	34	46	μA
Discharge Current in OVP Mode	I_{VIN_OVP}	$V_{VIN}=12V$ (Note 4)	5	7	10	mA
Error Amplifier Section						
Internal Reference Voltage	V_{REF}		294	300	306	mV
Current Sense Section						
Current Limit Reference Voltage	V_{ISEN_MAX}		0.4	0.45	0.5	V
ZCS Pin Section						
ZCS Pin OVP Voltage Threshold	V_{ZCS_OVP}		1.43	1.5	1.57	V
Gate Driver Section						
Gate Driver Voltage	V_{GATE}		9.5	12	14.5	V
Maximum Source Current	I_{SOURCE}		150	200	250	mA
Minimum Sink Current	I_{SINK}		500	650	800	mA
Max ON Time	T_{ON_MAX}	$V_{COMP}=2.6V$		16		μs
Min ON Time	T_{ON_MIN}			450		ns
Max OFF Time	T_{OFF_MAX}			60		μs
Min OFF Time	T_{OFF_MIN}			1.5		μs
Maximum Switching Frequency	F_{MAX}			120		kHz
ADIM function Section						
ADIM Enable ON	V_{ADIM_ON}		32	42	52	mV
ADIM Enable OFF	V_{ADIM_OFF}		20	30	40	mV
Thermal Section						
Thermal Fold Back Temperature	T_{FB}			150		$^\circ C$
Thermal shut Down Temperature	T_{SD}			160		$^\circ C$
PWM Function Section						
PWM ON Voltage	V_{PWM_ON}				1.2	V
PWM OFF Voltage	V_{PWM_OFF}		0.5			V

Note 1: Stresses beyond the “Absolute Maximum Ratings” may cause permanent damage to the device. These are stress ratings only. Functional operation of the device at these or any other conditions beyond those indicated in the operational sections of the specification is not implied. Exposure to absolute maximum rating conditions for extended periods may affect device reliability.

Note 2: Θ_{JA} is measured in the natural convection at $T_A = 25^\circ C$ on a low effective single layer thermal conductivity test board of JEDEC 51-3 thermal measurement standard. Test condition: Device mounted on 2” x 2” FR-4 substrate PCB, 2oz copper, with minimum recommended pad on top layer and thermal vias to bottom layer ground plane.

Note 3: Increase VIN pin voltage gradually higher than V_{VIN_ON} voltage then turn down to 12V.

Note 4: Increase VIN pin voltage gradually higher than V_{VIN_OVP} voltage then turn down to 12V.

Typical Performance Characteristic

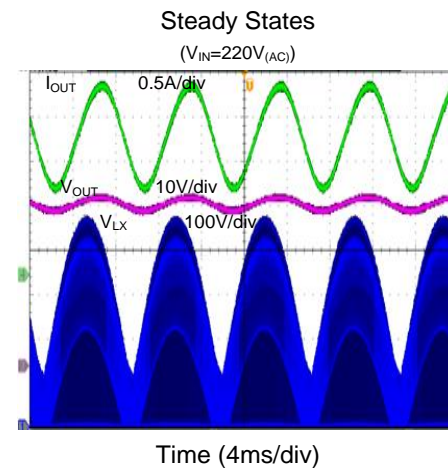
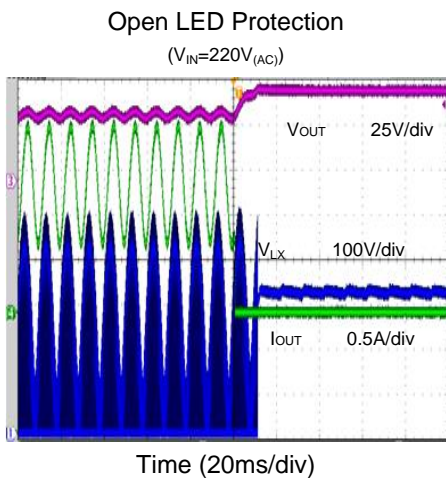
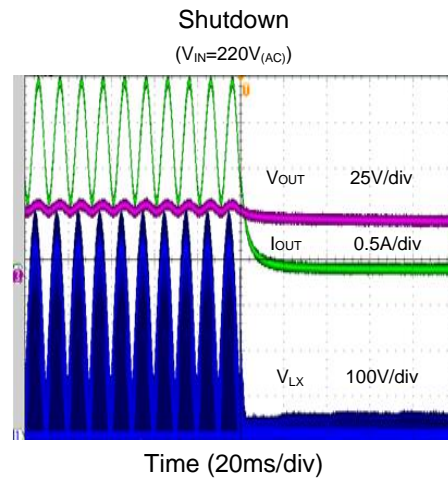
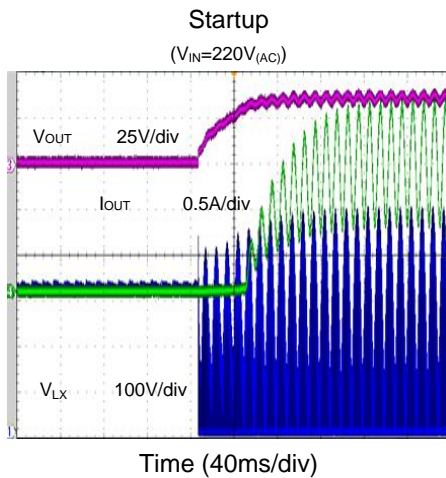
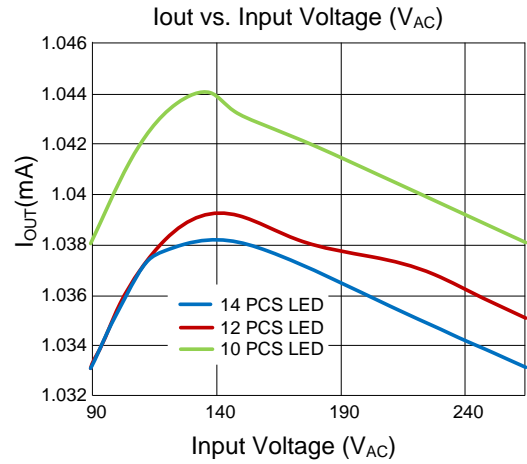
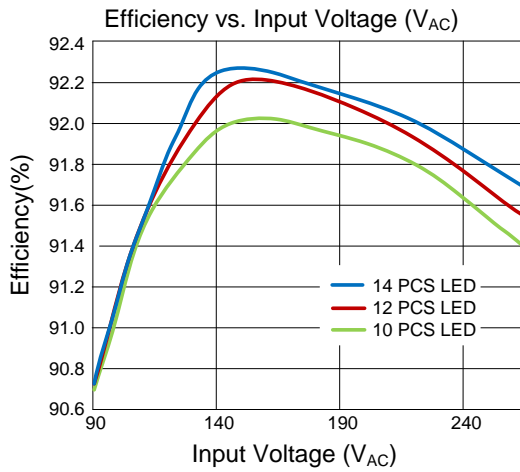

Operation

The SY5882N is a single stage Flyback and PFC controller targeting at LED lighting applications with PWM/Analog dimming function.

SY5882N provides primary side control to eliminate the opto-couplers and the secondary feedback circuits, which can decrease the BOM cost of the system design.

High power factor is achieved by constant on time operation mode, with which both the control scheme and the circuit structure are simple.

SY5882N is compatible with analog dimming and PWM dimming for different application.

In order to reduce the switching loss and improve EMI performance, Quasi-Resonant switching mode is applied. The maximum switching frequency is limited at 120KHz to reduce switching losses and improve EMI performance when the converter is operated at light load condition.

SY5882N provides reliable protections such as Short Circuit Protection (SCP), Open LED Protection (OLP), Over Temperature Protection (OTP), etc.

SY5882N is available with SO8 package.

Applications Information

Start up

After AC supply or DC BUS is powered on, the capacitor C_{VIN} between V_{IN} and GND pin is charged up by BUS voltage through a start up resistor R_{ST} . Once V_{VIN} rises up to $V_{VIN,ON}$, the internal blocks start to work. V_{VIN} will be pulled down by internal consumption of IC until the auxiliary winding of transformer could supply enough energy to maintain V_{VIN} above $V_{VIN,OFF}$.

The whole start up procedure is divided into four sections shown in Fig.4. t_{STC} is the C_{VIN} charged up section, and t_{STO} is the output voltage build-up section. The start-up time t_{ST} is composed of t_{STC} and t_{STO} , and usually t_{STO} is much smaller than t_{STC} .

t_{STO} is fast start-up stage, which will help to create output voltage quickly. After t_{STO} , if V_{ADIM} is less than $V_{ADIM,ON}$, IC enters into CV mode. When V_{ADIM} is larger than $V_{ADIM,ON}$, IC works in constant on time mode.

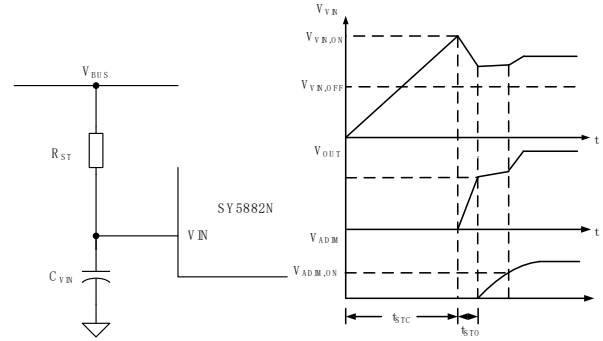

Fig.4 Start up

The start up resistor R_{ST} and C_{VIN} are designed by rules as below:

(a) Preset start-up resistor R_{ST} , make sure that the current through R_{ST} is larger than I_{ST} and smaller than 1mA.

$$\frac{V_{BUS}}{1mA} < R_{ST} < \frac{V_{BUS}}{I_{ST}} \quad (1)$$

Where V_{BUS} is the BUS line voltage

(b) Select C_{VIN} to obtain an ideal start up time t_{ST} , and ensure the output voltage is built up at one time.

$$C_{VIN} = \frac{\left(\frac{V_{BUS}}{R_{ST}} - I_{ST}\right) \times t_{ST}}{V_{VIN,ON}} \quad (2)$$

(d) If the C_{VIN} is not big enough to build up the output voltage at one time. Increase C_{VIN} and decrease R_{ST} , go back to step (a) and redo such design flow until the ideal start up procedure is obtained.

Internal pre-charge design for quick start up

In P3, V_{COMP} is pre-charged by internal current source until it is over the initial voltage V_{COMP_IC} . V_{COMP_IC} can be programmed by R_{COMP} . Such design is meant to reduce the start up time shown in Fig.5.

The voltage pre-charged V_{COMP_IC} in start-up procedure can be programmed by R_{COMP} .

$$V_{COMP_IC} = 1.35V - 300\mu A \times R_{COMP} \quad (3)$$

Where V_{COMP_IC} is the pre-charged voltage of COMP pin.

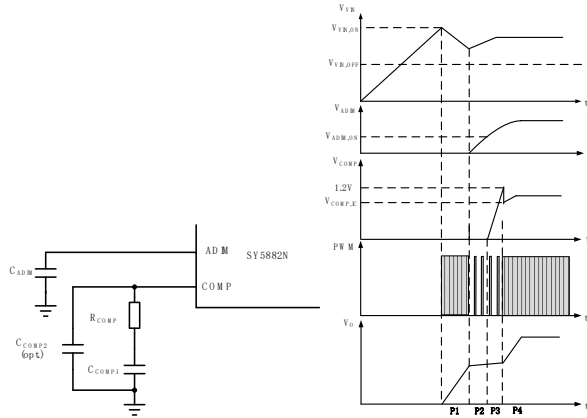

Fig.5 Pre-charge scheme in start up

Generally, a big capacitance of C_{COMP} is necessary to achieve high power factor and stabilize the system loop ($1\mu F \sim 4.7\mu F$ is recommended).

The voltage pre-charged in start-up procedure can be programmed by R_{COMP} ; On the other hand, larger R_{COMP} can provide larger phase margin for the control loop; A small ceramic capacitor is added to suppress high frequency interruption ($10pF \sim 100pF$ is recommended if necessary)

Shut down

After AC supply or DC BUS is powered off, the energy stored in the BUS capacitor will be discharged. When the auxiliary winding of the transformer can not supply enough energy to V_{IN} pin, V_{VIN} will drop down. Once V_{VIN} is below $V_{VIN,OFF}$, the IC will stop working and V_{COMP} will be discharged to zero.

Primary side constant current control

Primary side control is applied to eliminate secondary feedback circuit and opto-coupler, which reduces the BOM cost. The switching waveforms are shown in Fig.6.

The output current I_{OUT} can be represented by,

$$I_{OUT} = \frac{I_{SP}}{2} \times \frac{t_{DIS}}{t_s} \quad (4)$$

Where I_{SP} is the peak current of the secondary side; t_{DIS} is the discharge time of the transformer; t_s is the switching period.

The secondary peak current is related with primary peak current, if the effect of the leakage inductor is neglected.

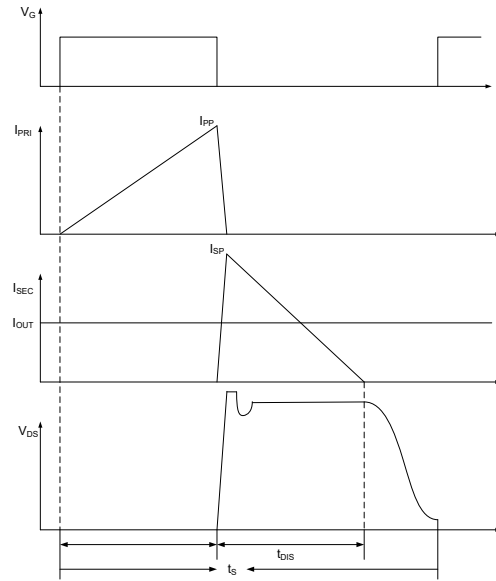

Fig.6 switching waveforms

$$I_{SP} = N_{PS} \times I_{PP} \quad (5)$$

Where N_{PS} is the turn ratio of primary to secondary of the transformer.

Thus, I_{OUT} can be represented by

$$I_{OUT} = \frac{N_{PS} \times I_{PP}}{2} \times \frac{t_{DIS}}{t_s} \quad (6)$$

The primary peak current I_{PP} and inductor current discharge time t_{DIS} can be detected by I_{SEN} and ZCS pin, which is shown in Fig.7. These signals are processed and applied to the negative input of the gain modulator. In static state, the positive and negative inputs are equal.

$$V_{REF} = I_{PP} \times R_s \times \frac{t_{DIS}}{t_s} \times k_1 \quad (7)$$

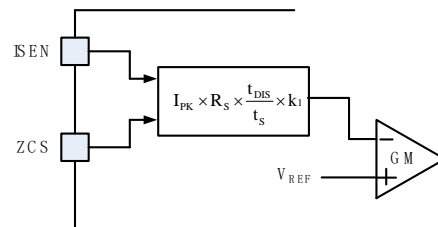

Fig.7 Output current detection diagram

Finally, the output current I_{OUT} can be represented by

$$I_{OUT} = \frac{V_{REF} \times N_{PS}}{R_S \times 2 \times k_1} \quad (8)$$

Where k_1 is the output current weight coefficient; k_2 is the output modification coefficient; V_{REF} is the internal reference voltage; R_S is the current sense resistor.

k_1 and V_{REF} are all internal constant parameters, I_{OUT} can be programmed by N_{PS} and R_S .

$$R_S = \frac{V_{REF} \times N_{PS}}{I_{OUT} \times 2 \times k_1} \quad (9)$$

Then

$$R_S = \frac{k \times V_{REF} \times N_{PS}}{I_{OUT}}, k = \frac{1}{2k_1} \quad (10)$$

Quasi-Resonant Operation

QR mode operation provides low turn-on switching losses for the converter.

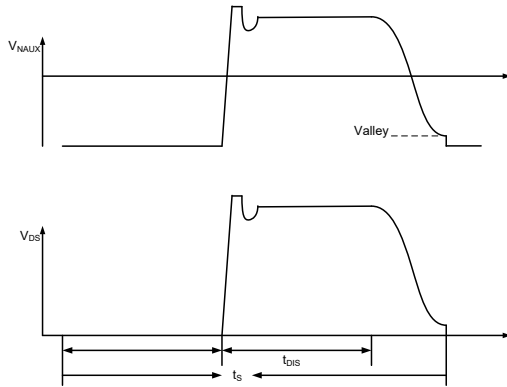

Fig.8 QR mode operation

The voltage across drain and source of the primary MOSFET is reflected by the auxiliary winding of the Flyback transformer. ZCS pin detects the voltage across the auxiliary winding by a resistor divider. When the voltage across drain and source of the primary MOSFET is at voltage valley, the MOSFET would be turned on.

CV Mode

When PWM < 1.8%, IC still need bias power:

(1) If Dimming signal is greater than 2.5%, IC always works at CC mode.

(2) If Dimming signal is lower than 1.8%, CV mode is triggered. IC works in CV mode to maintain V_{ZCS} nearby $V_{ZCS,CV}$ (0.5V). N_P : N_{AUX} and R_{ZCS} can be adjusted to prevent LED flicker and keep bias supply enough at CV mode.

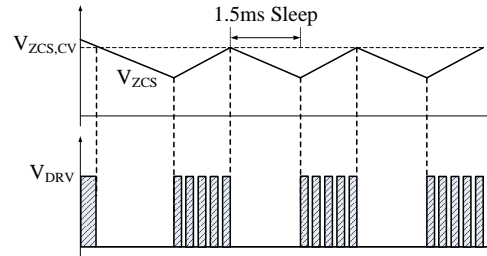

Figure.9 The working process of CV mode

In CV mode, which is shown in Fig.9.

(1) If V_{ZCS} is greater than $V_{ZCS,CV}$ (0.5V), IC will sleep for 1.5ms.

(2) After 1.5ms sleep, if V_{ZCS} is smaller than $V_{ZCS,CV}$, IC will work until V_{ZCS} is greater than $V_{ZCS,CV}$. During this time, MOSFET turns on by QR and turns off until the ISEN voltage reach 0.05V.

The output of CV can be calculated as below:

$$V_{OUT,CV} = 0.5V \times \left(\frac{R_{ZCSU} + R_{ZCSD}}{R_{ZCSD}} \right) \times \frac{N_S}{N_{AUX}} \quad (11)$$

Where, R_{ZCSU} is the upper resistor of ZCS pin; R_{ZCSD} is the down resistor of ZCS pin; N_S and N_{AUX} are the turns of secondary winding and auxiliary winding separately.

Over Voltage Protection (OVP) & Open LED Protection (OLP)

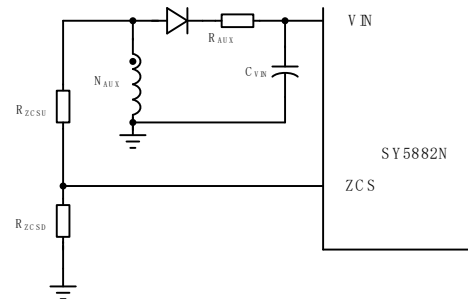

Fig.10 OVP&OLP

The output voltage is reflected by the auxiliary winding voltage of the Flyback transformer, and both ZCS pin and VIN pin provide over voltage protection function. When the load is null or large transient happens, the output voltage will exceed the rated value. When V_{VIN} exceeds $V_{VIN,OVP}$ or V_{ZCS} exceeds $V_{ZCS,OVP}$, the over

voltage protection is triggered and the IC will discharge V_{VIN} by an internal current source. Once V_{VIN} is below $V_{VIN,OFF}$, the IC will shut down and be charged again by BUS voltage through start up resistor. If the over voltage condition still exists, the system will operate in hiccup mode.

Thus, the turns of the auxiliary winding N_{AUX} and the resistor divider is related with the OVP function.

$$\frac{V_{ZCS_OVP}}{V_{OVP}} = \frac{N_{AUX}}{N_S} \times \frac{R_{ZCSD}}{R_{ZCSU} + R_{ZCSD}} \quad (12)$$

$$\frac{V_{VIN_OVP}}{V_{OVP}} \geq \frac{N_{AUX}}{N_S} \quad (13)$$

Where V_{OVP} is the output over voltage specification; R_{ZCSU} and R_{ZCSD} compose the resistor divider. The turn ratio of N_S to N_{AUX} and the ratio of R_{ZCSU} to R_{ZCSD} could be induced from equation (12) and (13).

Short Circuit Protection (SCP)

When the output is shorted to ground, the output voltage is clamped to zero. The voltage of the auxiliary winding is proportional to the output winding, so valley signal cannot be detected by VSEN. Without valley detection, MOSFET cannot be turned ON until maximum off time $t_{OFF,MAX}$ is matched. If MOSFET is turned ON by $t_{OFF,MAX}$ 64 times continuously, IC will be shut down and enter into hiccup mode.

If the output voltage is not low enough to disable valley detection in short condition, V_{VIN} will drop down without auxiliary winding supply. Once V_{VIN} is below $V_{VIN,OFF}$, the IC will shut down and be charged again by the BUS voltage through the start-up resistor. If the short circuit condition still exists, the system will operate in hiccup mode.

In order to guarantee SCP function is not effected by voltage spike of auxiliary winding, a filter resistor R_{AUX} is needed (10Ω typically) shown in Fig.10.

Line Regulation Modification

The IC provides line regulation improvement function by adjusting the external resistor.

Due to the sample delay of ISEN pin and other internal delay, the output current increases with the increasing of input BUS line voltage. A small compensation voltage $\Delta V_{ISEN,C}$ is added to ISEN pin during ON time to improve

such performance. This $\Delta V_{ISEN,C}$ is adjusted by the upper resistor of the divider connected to ZCS pin and external resistor $R_{ISEN,C}$ on ISEN pin.

$$\Delta V_{ISEN,C} = V_{BUS} \times \frac{N_{AUX}}{N_P} \times \frac{1}{R_{ZCSU}} \times k_2 \times (R_{k2} + R_{ISEN,C}) \quad (14)$$

Where R_{VSENU} is the upper resistor of the divider; k_2 is an internal constant as the modification coefficient; R_{k2} is an internal feed-forward resistor; auxiliary resistor $R_{ISEN,C}$ can be added to enhance feed-forward effects.

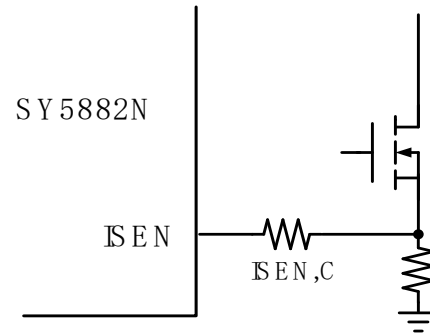

Fig.11 Feed-forward resistor

The compensation is mainly related with R_{ZCSU} , larger compensation is achieved with smaller R_{ZCSU} . Normally, R_{ZCS} ranges from $100k\Omega \sim 1M\Omega$.

Then R_{ZCSD} can be selected by,

$$V_{IN_CV} = \frac{0.5 \cdot (R_{ZCSU} + R_{ZCSD})}{R_{ZCSD}} \geq 11 \quad (15)$$

And,

$$R_{ZCSD} = \frac{0.5 \cdot R_{ZCSU}}{V_{IN_CV} - 0.5} \times R_{ZCSU} \quad (16)$$

Where V_{OVP} is the output over voltage protection specification; V_{OUT} is the rated output voltage; R_{ZCSU} is the upper resistor of the divider; N_S and N_{AUX} are the turns of secondary winding and auxiliary winding separately.

Dimming Mode

SY5882N supports PWM input and 0~1.65V input.

- 0~1.65V input dimming:

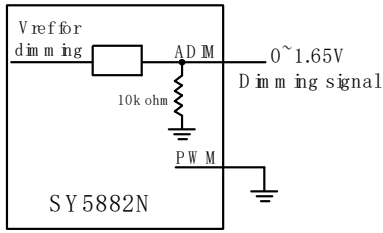

Fig.12 0~1.65V input dimming

If V_{ADIM} is lower than $V_{ADIM,OFF}$ (30mV), the output current is decreased to zero; While V_{ADIM} is increased from $V_{ADIM,OFF}$ to $V_{ADIM,ON}$ (42mV), the output current is created and the value is 2.5 percent of full load output current; When V_{ADIM} is higher than 1.65V, the output current is 100 percent of full load output current;

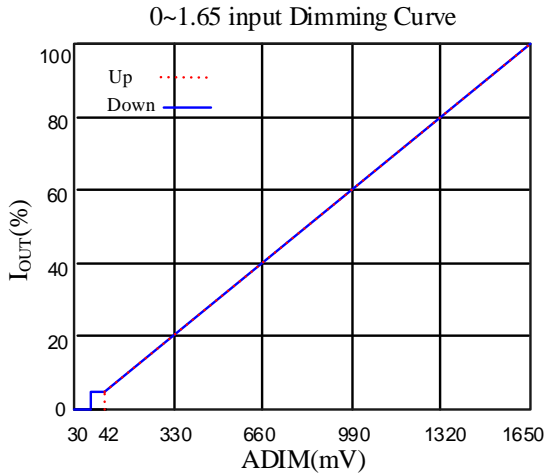

Fig.13 Dimming curve of analog dimming

As showed above, the available dimming range of V_{ADIM} is from 42mV to 1650mV.

2) .PWM input dimming

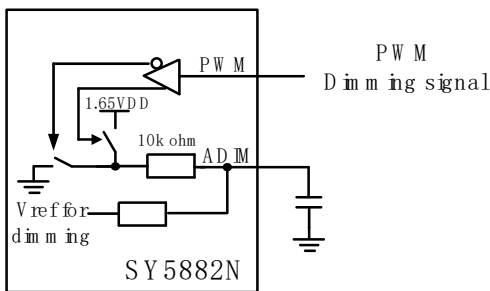

Fig.14 PWM input dimming

If the dimming signal is PWM signal, as showed above, there is a RC filter to convert the signal.

When the voltage of PWM pin is higher than $V_{PWM,ON}$, the dimming signal is sensed as high logic level, and ADIM pin is pulled up to 1.65V by a 10kΩ resistor; when the voltage of PWM pin is lower than $V_{PWM,OFF}$, the dimming signal is sensed as low logic level, and ADIM pin is pulled down to GND by a 10kΩ resistor.

The duty cycle of PWM signal is reflected by the voltage on ADIM pin V_{ADIM} .

$$V_{ADIM} = D_{PWM} \times 1.65V \quad (17)$$

So the relationship between the output current and the PWM input is showed below:

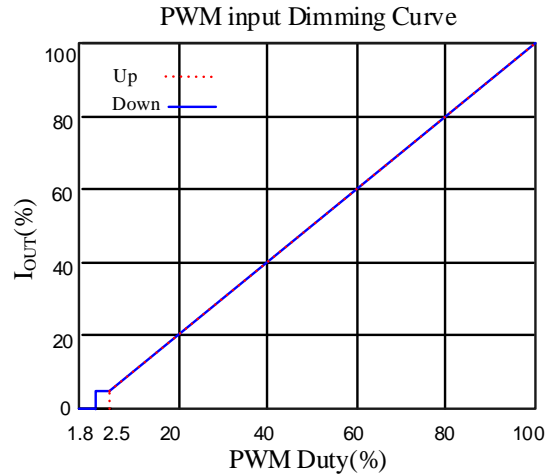

Fig.15 the dimming curve of PWM input

A capacitor C_{ADIM} need be connected across ADIM and GND pin to obtain a smooth voltage waveform of the dimming signal duty cycle. C_{ADIM} is selected by (for 1KHz PWM, 1uF typically)

$$C_{ADIM} \geq \frac{10^{-3}}{f_{DIM}} \text{ F} \cdot \text{Hz} \quad (18)$$

f_{DIM} is the frequency of PWM dimming signal.

Power Device Design

MOSFET and Diode

When the operation condition is with maximum input voltage and full load, the voltage stress of MOSFET and secondary power diode is maximized;

$$V_{MOS_DS_MAX} = \sqrt{2}V_{AC_MAX} + N_{PS} \times (V_{OUT} + V_{D_F}) + \Delta V_S \quad (19)$$

$$V_{D_R_MAX} = \frac{\sqrt{2}V_{AC_MAX}}{N_{PS}} + V_{OUT} \quad (20)$$

Where V_{AC_MAX} is the maximum input AC RMS voltage; N_{PS} is the turn ratio of the Flyback transformer; V_{OUT} is the rated output voltage; V_{D_F} is the forward voltage of secondary power diode; ΔV_S is the overshoot voltage clamped by RCD snubber during OFF time.

When the operation condition is with minimum input voltage and full load, the current stress of MOSFET and power diode is maximized.

$$I_{MOS_PK_MAX} = I_{P_PK_MAX} \quad (21)$$

$$I_{MOS_RMS_MAX} = I_{P_RMS_MAX} \quad (22)$$

$$I_{D_PK_MAX} = N_{PS} \times I_{P_PK_MAX} \quad (23)$$

$$I_{D_AVG} = I_{OUT} \quad (24)$$

Where $I_{P_PK_MAX}$ and $I_{P_RMS_MAX}$ are maximum primary peak current and RMS current, which will be introduced later.

Transformer (N_{PS} and L_M)

N_{PS} is limited by the electrical stress of the power MOSFET:

$$N_{PS} \leq \frac{V_{MOS_BR_DS} \times 90\% - \sqrt{2}V_{AC_MAX} - \Delta V_S}{V_{OUT} + V_{D_F}} \quad (25)$$

Where $V_{MOS_BR_DS}$ is the breakdown voltage of the power MOSFET.

In Quasi-Resonant mode, each switching period cycle t_s consists of three parts: current rising time t_1 , current falling time t_2 and quasi-resonant time t_3 are shown as Fig.12.

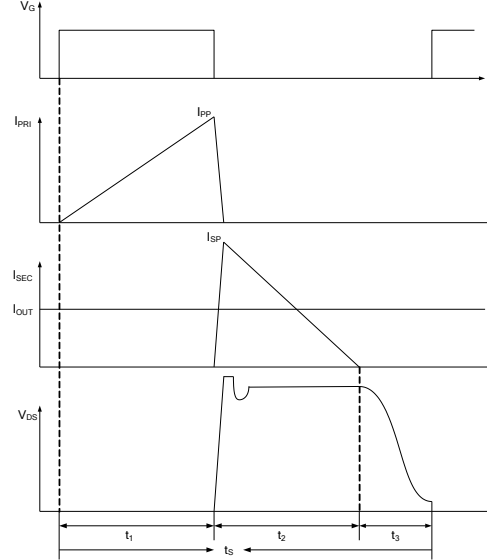

Fig.16 switching waveforms

The system operates in the constant on time mode to achieve high power factor. The ON time increases with the decreasing of input AC RMS voltage and the increasing of load. When the operation condition is with minimum input AC RMS voltage and full load, the ON time is maximized. On the other hand, when the input voltage is at the peak value, the OFF time is maximized. Thus, the minimum switching frequency f_{S_MIN} happens at the peak value of input voltage with minimum input AC RMS voltage and maximum load condition; meanwhile, the maximum peak current through MOSFET and the transformer happens.

Once the minimum frequency f_{S_MIN} is set, the inductance of the transformer could be induced. The design flow is shown as below:

(a) Select N_{PS}

$$N_{PS} \leq \frac{V_{MOS_BR_DS} \times 90\% - \sqrt{2}V_{AC_MAX} - \Delta V_S}{V_{OUT} + V_{D_F}} \quad (26)$$

(b) Preset minimum frequency f_{S_MIN}

(c) Compute relative t_s , t_1 (t_3 is omitted to simplify the design here)

$$t_s = \frac{1}{f_{S_MIN}} \quad (27)$$

$$t_1 = \frac{t_s \times N_{PS} \times (V_{OUT} + V_{D_F})}{\sqrt{2}V_{AC_MIN} + N_{PS} \times (V_{OUT} + V_{D_F})} \quad (28)$$

(d) Design inductance L_M

$$L_M = \frac{V_{AC_MIN}^2 \times t_1^2 \times \eta}{2P_{OUT} \times t_S} \quad (29)$$

(e) Compute t_3

$$t_3 = \pi \times \sqrt{L_M \times C_{Drain}} \quad (30)$$

Where C_{Drain} is the parasitic capacitance at drain of MOSFET.

(f) Compute primary maximum peak current $I_{P_PK_MAX}$ and RMS current $I_{P_RMS_MAX}$ for the transformer fabrication.

$$I_{P_PK_MAX} = \frac{2P_{OUT} \times \left[\frac{L_M}{\sqrt{2}V_{AC_MIN}} + \frac{L_M}{N_{PS} \times (V_{OUT} + V_{D,F})} \right]}{L_M \times \eta} + \frac{\sqrt{4P_{OUT}^2 \times \left[\frac{L_M}{\sqrt{2}V_{AC_MIN}} + \frac{L_M}{N_{PS} \times (V_{OUT} + V_{D,F})} \right]^2 + 4L_M \times \eta \times P_{OUT} \times t_3}}{L_M \times \eta} \quad (31)$$

Where η is the efficiency; P_{OUT} is rated full load power

Adjust t_1 and t_S to t_1' and t_S' considering the effect of t_3

$$t_S' = \frac{\eta \times L_M \times I_{P_PK_MAX}^2}{4P_{OUT}} \quad (32)$$

$$t_1' = \frac{L_M \times I_{P_PK_MAX}}{\sqrt{2}V_{AC_MIN}} \quad (33)$$

$$I_{P_RMS_MAX} \approx \sqrt{\frac{t_1'}{6t_S'}} \times I_{P_PK_MAX} \quad (34)$$

(g) Compute secondary maximum peak current $I_{S_PK_MAX}$ and RMS current $I_{S_RMS_MAX}$ for the transformer fabrication.

$$I_{S_PK_MAX} = N_{PS} \times I_{P_PK_MAX} \quad (35)$$

$$t_2' = t_S' - t_1' - t_3 \quad (36)$$

$$I_{S_RMS_MAX} \approx \sqrt{\frac{t_2'}{6t_S'}} \times I_{S_PK_MAX} \quad (37)$$

Transformer Design (N_P, N_S, N_{AUX})

The design of the transformer is similar with ordinary Flyback transformer. The parameters below are necessary:

Necessary parameters	
Turns ratio	N_{PS}
Inductance	L_M
Primary maximum current	$I_{P_PK_MAX}$
Primary maximum RMS current	$I_{P_RMS_MAX}$
Secondary maximum RMS current	$I_{S_RMS_MAX}$

The design rules are as followed:

(a) Select the magnetic core style, identify the effective area A_e .

(b) Preset the maximum magnetic flux ΔB

$$\Delta B = 0.22 \sim 0.26 T$$

(c) Compute primary turn N_P

$$N_P = \frac{L_M \times I_{P_PK_MAX}}{\Delta B \times A_e} \quad (38)$$

(d) Compute secondary turn N_S

$$N_S = \frac{N_P}{N_{PS}} \quad (39)$$

(e) Compute auxiliary turn N_{AUX}

$$N_{AUX} = N_S \times \frac{V_{VIN}}{V_{OUT}} \quad (40)$$

Where V_{VIN} is the working voltage of VIN pin (12V~15V is recommended).

(f) Select an appropriate wire diameter

With $I_{P_RMS_MAX}$ and $I_{S_RMS_MAX}$, select appropriate wire to make sure the current density ranges from 4A/mm² to 10A/mm².

(g) If the winding area of the core and bobbin is not enough, reselect the core style, go to (a) and redesign the transformer until the ideal transformer is achieved.

Output Capacitor C_{OUT}

Preset the output current ripple ΔI_{OUT} , C_{OUT} is induced by

$$C_{OUT} = \frac{\sqrt{\left(\frac{2I_{OUT}}{\Delta I_{OUT}}\right)^2 - 1}}{4\pi f_{AC} R_{LED}} \quad (41)$$

Where I_{OUT} is the rated output current; ΔI_{OUT} is the demanded current ripple; f_{AC} is the input AC supply frequency; R_{LED} is the equivalent series resistor of the LED load.

RCD Snubber for MOSFET

The power loss of the snubber P_{RCD} is evaluated first

$$P_{RCD} = \frac{N_{PS} \times (V_{OUT} + V_{D,F}) + \Delta V_S}{\Delta V_S} \times \frac{L_K}{L_M} \times P_{OUT} \quad (42)$$

Where N_{PS} is the turns ratio of the Flyback transformer; V_{OUT} is the output voltage; $V_{D,F}$ is the forward voltage of the power diode; ΔV_S is the overshoot voltage clamped by RCD snubber; L_K is the leakage inductor; L_M is the inductance of the Flyback transformer; P_{OUT} is the output power.

The R_{RCD} is related with the power loss:

$$R_{RCD} = \frac{(N_{PS} \times (V_{OUT} + V_{D,F}) + \Delta V_S)^2}{P_{RCD}} \quad (43)$$

The C_{RCD} is related with the voltage ripple of the snubber ΔV_{C_RCD} :

$$C_{RCD} = \frac{N_{PS} \times (V_{OUT} + V_{D,F}) + \Delta V_S}{R_{RCD} f_S \Delta V_{C_RCD}} \quad (44)$$

Layout

(a) To achieve better EMI performance and reduce line frequency ripples, the output of the bridge rectifier should be connected to the BUS line capacitor first, then to the switching circuit.

(b) The circuit loop of all switching circuit should be kept small: primary power loop, secondary loop and auxiliary power loop.

(c) Bias supply trace should be connected to the bias supply capacitor first instead of GND pin. The bias supply capacitor should be put beside the IC.

(d) Loop of 'Source pin – current sample resistor – GND pin' should be kept as small as possible.

(e) The resistor divider is recommended to be put beside the IC.

(f) The connection of ground is recommended as:

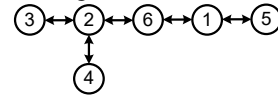

Ground ①: ground of BUS line capacitor

Ground ②: ground of bias supply capacitor and GND pin

Ground ③: ground node of auxiliary winding

Ground ④: ground of signal trace except GND pin

Ground ⑤: primary ground node of Y capacitor.

Ground ⑥: ground of current sample resistor.

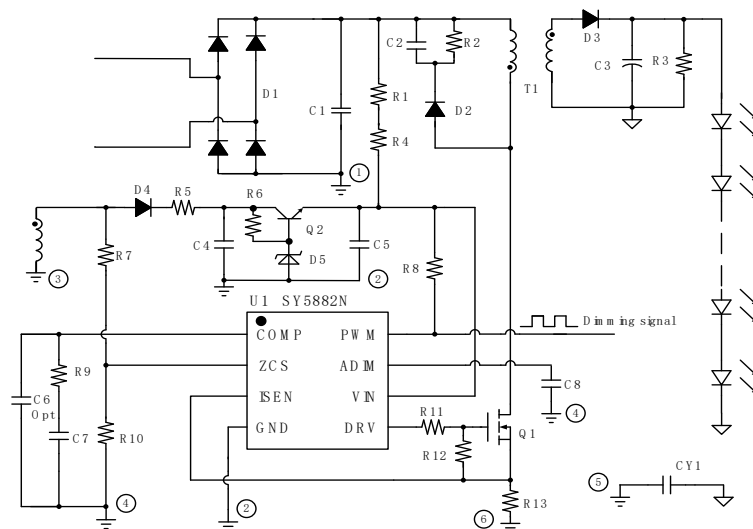

Fig.17 Ground Layout

Design Example

A design example of typical application is shown below step by step.

#1. Identify design specification

Design Specification			
$V_{AC(RMS)}$	90V~264V	V_{OUT}	42V
I_{OUT}	1000mA	η	89%

#2. Transformer design (N_{PS} , L_M)

Refer to Power Device Design

Conditions			
V_{AC_MIN}	90V	V_{AC_MAX}	264V
ΔV_S	50V	$V_{MOS_ (BR)DS}$	600V
P_{OUT}	42W	$V_{D,F}$	1V
C_{Drain}	100pF	f_{S_MIN}	75kHz

(a) Compute turns ratio N_{PS} first

$$\begin{aligned}
 N_{PS} &\leq \frac{V_{MOS_ (BR)DS} \times 90\% - \sqrt{2}V_{AC_MAX} - \Delta V_S}{V_{OUT} + V_{D,F}} \\
 &= \frac{600V \times 0.9 - \sqrt{2} \times 264V - 50V}{42V + 1V} \\
 &= 2.71
 \end{aligned}$$

N_{PS} is set to

$$N_{PS} = 2.60$$

(b) f_{S_MIN} is preset

$$f_{S_MIN} = 42kHz$$

(c) Compute the switching period t_S and ON time t_1 at the peak of input voltage.

$$t_S = \frac{1}{f_{S_MIN}} = 23.8\mu s$$

$$\begin{aligned}
 t_1 &= \frac{t_S \times N_{PS} \times (V_{OUT} + V_{D,F})}{\sqrt{2}V_{AC_MIN} + N_{PS} \times (V_{OUT} + V_{D,F})} \\
 &= \frac{23.8\mu s \times 2.60 \times (42V + 1V)}{\sqrt{2} \times 90V + 2.60 \times (42V + 1V)} \\
 &= 11.13\mu s
 \end{aligned}$$

(d) Compute the inductance L_M

$$\begin{aligned}
 L_M &= \frac{V_{AC_MIN}^2 \times t_1^2 \times \eta}{2P_{OUT} \times t_s} \\
 &= \frac{90V^2 \times 11.13\mu s^2 \times 0.89}{2 \times 42W \times 23.8\mu s} \\
 &= 446.693\mu H
 \end{aligned}$$

Set

$$L_M = 440\mu H$$

(e) Compute the quasi-resonant time t_3

$$\begin{aligned}
 t_3 &= \pi \times \sqrt{L_M \times C_{Drain}} \\
 &= \pi \times \sqrt{440\mu H \times 100pF} \\
 &\approx 659ns
 \end{aligned}$$

(f) Compute primary maximum peak current $I_{P_PK_MAX}$

$$\begin{aligned}
 I_{P_PK_MAX} &= \frac{2P_{OUT} \times \left[\frac{L_M}{\sqrt{2}V_{AC_MIN}} + \frac{L_M}{N_{PS} \times (V_{OUT} + V_{D,F})} \right]}{L_M \times \eta} + \sqrt{\frac{4P_{OUT}^2 \times \left[\frac{L_M}{\sqrt{2}V_{AC_MIN}} + \frac{L_M}{N_{PS} \times (V_{OUT} + V_{D,F})} \right]^2 + 4L_M \times \eta \times P_{OUT} \times t_3}{L_M \times \eta}} \\
 &= 3.26A
 \end{aligned}$$

Adjust switching period t_s and ON time t_1 to t'_s and t'_1 .

$$\begin{aligned}
 t'_s &= \frac{\eta \times L_M \times I_{P_PK_MAX}^2}{4P_{OUT}} \\
 &= \frac{0.89 \times 440\mu H \times 3.26A^2}{4 \times 42W} \\
 &= 24.772\mu s
 \end{aligned}$$

$$\begin{aligned}
 t'_1 &= \frac{L_M \times I_{P_PK_MAX}}{\sqrt{2}V_{AC_MIN}} \\
 &= \frac{440\mu H \times 3.26A}{\sqrt{2} \times 90V} \\
 &= 11.27\mu s
 \end{aligned}$$

Compute primary maximum RMS current $I_{P_RMS_MAX}$

$$I_{P_RMS_MAX} \approx \sqrt{\frac{t'_1}{6t'_s}} \times I_{P_PK_MAX} = \sqrt{\frac{11.27\mu s}{6 \times 24.772\mu s}} \times 3.26A = 0.90A$$

(g) Compute secondary maximum peak current and the maximum RMS current.

$$I_{S_PK_MAX} = N_{PS} \times I_{P_PK_MAX} = 2.60 \times 3.26A = 8.47A$$

$$t_2 = t'_s - t'_1 - t_3 = 24.772\mu s - 11.27\mu s - 0.659\mu s = 12.843\mu s$$

$$I_{S,RMS,MAX} \approx \sqrt{\frac{t'_2}{6t'_s}} \times I_{S,PK,MAX} = \sqrt{\frac{12.843\mu s}{6 \times 24.772\mu s}} \times 8.47A = 2.55A$$

#3. Select power MOSFET and secondary power diode

Refer to Power Device Design

Known conditions at this step			
$V_{AC,MAX}$	264V	N_{PS}	2.60
V_{OUT}	42V	$V_{D,F}$	1V
ΔV_S	50V	η	89%

(a) Compute the voltage and the current stress of MOSFET:

$$\begin{aligned} V_{MOS,DS,MAX} &= \sqrt{2}V_{AC,MAX} + N_{PS} \times (V_{OUT} + V_{D,F}) + \Delta V_S \\ &= \sqrt{2} \times 264V + 2.60 \times (42V + 1V) + 50V \\ &= 535V \end{aligned}$$

$$I_{MOS,PK,MAX} = I_{P,PK,MAX} = 3.26A$$

$$I_{MOS,RMS,MAX} = I_{P,RMS,MAX} = 0.90A$$

(b) Compute the voltage and the current stress of secondary power diode

$$\begin{aligned} V_{D,R,MAX} &= \frac{\sqrt{2}V_{AC,MAX}}{N_{PS}} + V_{OUT} \\ &= \frac{\sqrt{2} \times 264V}{2.60} + 42V \\ &= 186V \end{aligned}$$

$$I_{D,PK,MAX} = N_{PS} \times I_{P,PK,MAX} = 2.60 \times 3.26A = 8.47A$$

$$I_{D,AVG} = I_{OUT} = 1A$$

#4. Select the output capacitor C_{OUT}

Refer to Power Device Design

Conditions			
I_{OUT}	1000mA	ΔI_{OUT}	$0.3I_{OUT}$
f_{AC}	50Hz	R_{LED}	$12 \times 1.6\Omega$

The output capacitor is

$$C_{OUT} = \frac{\sqrt{\left(\frac{2I_{OUT}}{\Delta I_{OUT}}\right)^2 - 1}}{4\pi f_{AC} R_{LED}}$$

$$= \frac{\sqrt{\left(\frac{2 \times 1A}{0.3 \times 1A}\right)^2 - 1}}{4\pi \times 50Hz \times 12 \times 1.6\Omega}$$

$$= 546\mu F$$

#5. Set VIN pin

Refer to **Start up**

Conditions			
V _{BUS_MIN}	90V × 1.414	V _{BUS_MAX}	264V × 1.414
I _{ST}	34μA (typical)	V _{IN_ON}	22V (typical)
		t _{ST}	500ms (designed by user)

(a) R_{ST} is preset

$$R_{ST} < \frac{V_{BUS}}{I_{ST}} = \frac{90V \times 1.414}{34\mu A} = 3.7M\Omega,$$

$$R_{ST} > \frac{V_{BUS}}{1mA} = \frac{264V \times 1.414}{1mA} = 373k\Omega,$$

Set R_{ST}

$$R_{ST} = 300k\Omega \times 2 = 600k\Omega$$

(b) Design C_{VIN}

$$C_{VIN} = \frac{\left(\frac{V_{BUS}}{R_{ST}} - I_{ST}\right) \times t_{ST}}{V_{VIN_ON}}$$

$$= \frac{\left(\frac{90V \times 1.414}{600k\Omega} - 34\mu A\right) \times 500ms}{22V}$$

$$= 4\mu F$$

Set C_{VIN}

$$C_{VIN} = 4.7\mu F$$

#6 Set COMP pin

Refer to **Internal pre-charge design for quick start up**

Parameters designed			
R _{COMP}	1.5kΩ		
C _{COMP1}	1μF		

#7 Set current sense resistor to achieve ideal output current

Refer to **Primary-side constant-current control**

Known conditions at this step			
k	0.167	N _{PS}	2.60
V _{REF}	0.3V	I _{OUT}	1A

The current sense resistor is

$$R_s = \frac{k \times V_{REF} \times N_{PS}}{I_{OUT}}$$

$$= \frac{0.167 \times 0.3V \times 2.60}{1A}$$

$$= 0.13\Omega$$

#8 set ZCS pin

Refer to **Line regulation modification** and **Over Voltage Protection (OVP) & Open Loop Protection (OLP)**

First identify R_{ZCSU} need for line regulation.

Known conditions at this step			
K ₂	68		
Parameters Designed			
R _{ZCSU}	200kΩ		

Then compute R_{ZCSD} and N_{AUX}

Conditions			
V _{ZCS_OVP}	1.42V	V _{OVP}	58V
V _{OUT}	42V		
Parameters designed			
R _{ZCSU}	200kΩ		
N _S	14	N _{AUX}	

$$V_{IN_CV} = \frac{0.5 \cdot (R_{ZCSU} + R_{ZCSD})}{R_{ZCSD}} \geq 11$$

$$\frac{0.5}{10.5} \geq \frac{R_{ZCSD}}{R_{ZCSU}}$$

R_{ZCSUP}=200k ohm

$$R_{ZCSD} \leq 9.5$$

R_{ZCSD} is set to

$$R_{ZCSD} = 8.2k\Omega$$

Then set the N_{AUX} to

$$N_{SA} = \frac{V_{OVP}}{1.5 \cdot (R_{ZCSU} + R_{ZCSD})} = \frac{58}{1.5 \cdot (8.2k + 200k)} = 1.5$$

$$N_{SA} = \frac{R_{ZCSD}}{8.2k}$$

So N_{AUX} is

$$N_{AUX} = N_S / N_{SA} = 9$$

#9 set ADIM pin

$$C_{ADIM} = \frac{1.0 \times 10^{-3}}{f_{PWM}} F \times Hz = \frac{1.0 \times 10^{-3}}{f_{PWM}} F \times Hz = 1\mu F$$

Hence C_{ADIM} is set to

$$C_{ADIM} = 1\mu F$$

#10 final result

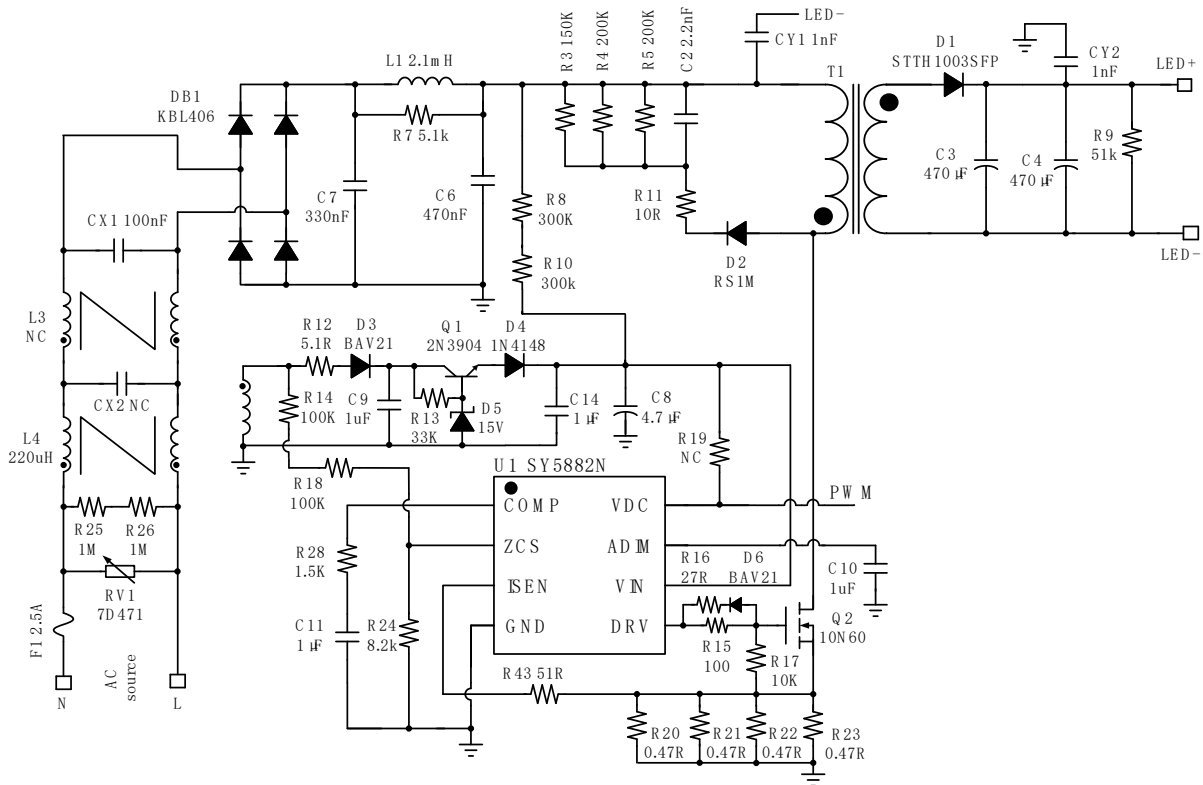
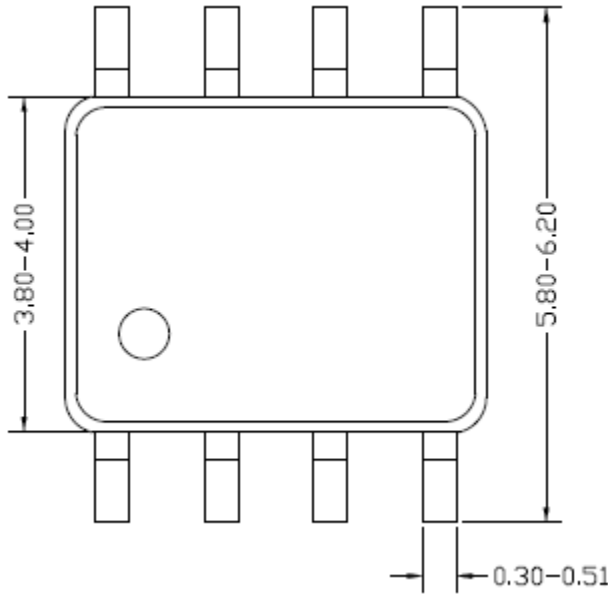
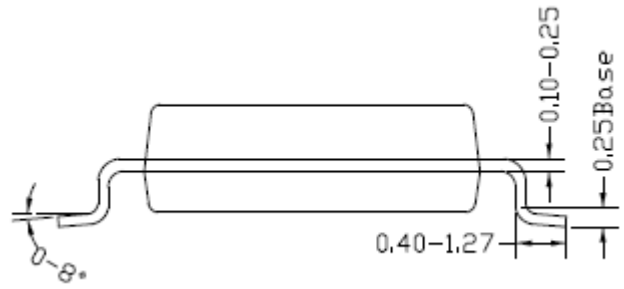

Fig.18 Final Design Result

SO8 Package outline & PCB layout design



Top view



Side view

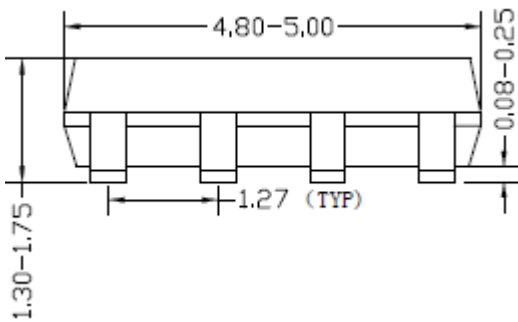

Front view

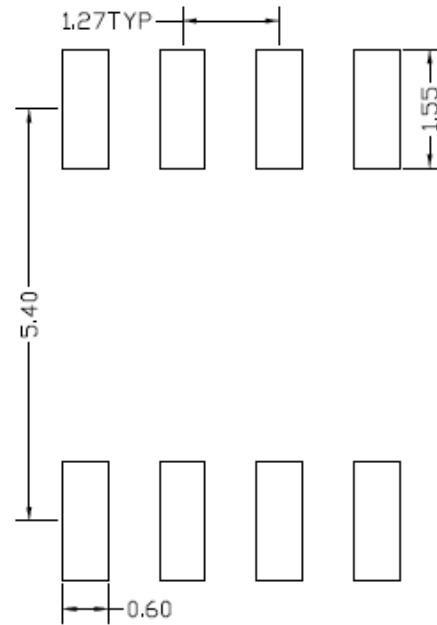

**Recommended Pad Layout
(Reference only)**

Notes: All dimension in millimeter and exclude mold flash & metal burr.

Taping & Reel Specification

1. Taping orientation for packages (SO8)

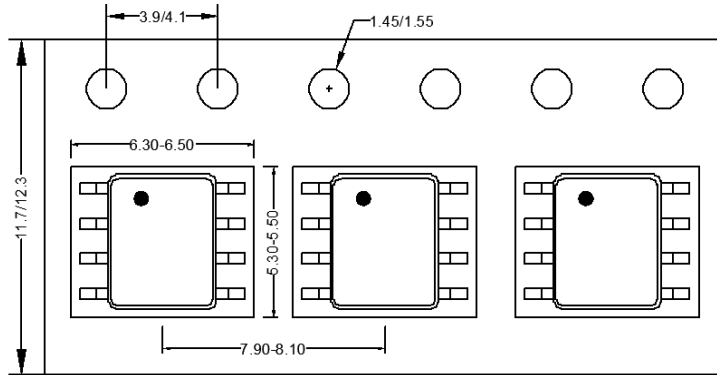

Feeding direction →

2. Carrier Tape & Reel specification for packages

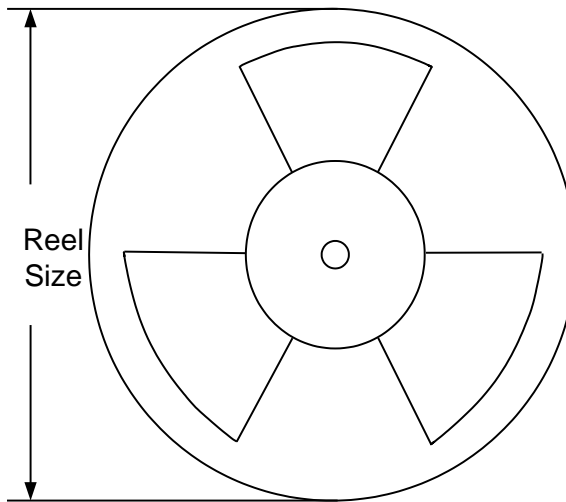

Package type	Tape width (mm)	Pocket pitch(mm)	Reel size (Inch)	Trailer length(mm)	Leader length (mm)	Qty per reel
SO8	12	8	13"	400	400	2500



Revision History

The revision history provided is for informational purpose only and is believed to be accurate, however, not warranted. Please make sure that you have the latest revision.

Date	Revision	Change
August 1, 2019	Revision 0.9	Initial Release

IMPORTANT NOTICE

- 1. Right to make changes.** Silergy and its subsidiaries (hereafter Silergy) reserve the right to change any information published in this document, including but not limited to circuitry, specification and/or product design, manufacturing or descriptions, at any time and without notice. This document supersedes and replaces all information supplied prior to the publication hereof. Buyers should obtain the latest relevant information before placing orders and should verify that such information is current and complete. All semiconductor products are sold subject to Silergy's standard terms and conditions of sale.
- 2. Applications.** Application examples that are described herein for any of these products are for illustrative purposes only. Silergy makes no representation or warranty that such applications will be suitable for the specified use without further testing or modification. Buyers are responsible for the design and operation of their applications and products using Silergy products. Silergy or its subsidiaries assume no liability for any application assistance or designs of customer products. It is customer's sole responsibility to determine whether the Silergy product is suitable and fit for the customer's applications and products planned. To minimize the risks associated with customer's products and applications, customer should provide adequate design and operating safeguards. Customer represents and agrees that it has all the necessary expertise to create and implement safeguards which anticipate dangerous consequences of failures, monitor failures and their consequences, lessen the likelihood of failures that might cause harm and take appropriate remedial actions. Silergy assumes no liability related to any default, damage, costs or problem in the customer's applications or products, or the application or use by customer's third-party buyers. Customer will fully indemnify Silergy, its subsidiaries, and their representatives against any damages arising out of the use of any Silergy components in safety-critical applications. It is also buyers' sole responsibility to warrant and guarantee that any intellectual property rights of a third party are not infringed upon when integrating Silergy products into any application. Silergy assumes no responsibility for any said applications or for any use of any circuitry other than circuitry entirely embodied in a Silergy product.
- 3. Limited warranty and liability.** Information furnished by Silergy in this document is believed to be accurate and reliable. However, Silergy makes no representation or warranty, expressed or implied, as to the accuracy or completeness of such information and shall have no liability for the consequences of use of such information. In no event shall Silergy be liable for any indirect, incidental, punitive, special or consequential damages, including but not limited to lost profits, lost savings, business interruption, costs related to the removal or replacement of any products or rework charges, whether or not such damages are based on tort or negligence, warranty, breach of contract or any other legal theory. Notwithstanding any damages that customer might incur for any reason whatsoever, Silergy' aggregate and cumulative liability towards customer for the products described herein shall be limited in accordance with the Standard Terms and Conditions of Sale of Silergy.
- 4. Suitability for use.** Customer acknowledges and agrees that it is solely responsible for compliance with all legal, regulatory and safety-related requirements concerning its products, and any use of Silergy components in its applications, notwithstanding any applications-related information or support that may be provided by Silergy. Silergy products are not designed, authorized or warranted to be suitable for use in life support, life-critical or safety-critical systems or equipment, nor in applications where failure or malfunction of an Silergy product can reasonably be expected to result in personal injury, death or severe property or environmental damage. Silergy assumes no liability for inclusion and/or use of Silergy products in such equipment or applications and therefore such inclusion and/or use is at the customer's own risk.
- 5. Terms and conditions of commercial sale.** Silergy products are sold subject to the standard terms and conditions of commercial sale, as published at <http://www.silergy.com/stdterms>, unless otherwise agreed in a valid written individual agreement specifically agreed to in writing by an authorized officer of Silergy. In case an individual agreement is concluded only the terms and conditions of the respective agreement shall apply. Silergy hereby expressly objects to and denies the application of any customer's general terms and conditions with regard to the purchase of Silergy products by the customer.
- 6. No offer to sell or license.** Nothing in this document may be interpreted or construed as an offer to sell products that is open for acceptance or the grant, conveyance or implication of any license under any copyrights, patents or other industrial or intellectual property rights. Silergy makes no representation or warranty that any license, either express or implied, is granted under any patent right, copyright, mask work right, or other intellectual property right. Information published by Silergy regarding third-party products or services does not constitute a license to use such products or services or a warranty or endorsement thereof. Use of such information may require a license from a third party under the patents or other intellectual property of the third party, or a license from Silergy under the patents or other intellectual property of Silergy.

For more information, please visit: www.silergy.com

© 2019 Silergy Corp.

All Rights Reserved.