



5.5V, 3A Low Loss Power Distribution Switch with Reverse Block Rating Up to 28V

General Description

The SY6863B2 is an ultra-low $R_{DS(ON)}$, 3A Low Loss power distribution switch with current limit to protect the power source from over current and short circuit conditions.

The SY6863B2 has over voltage protection and the output pin can withstand 28V. It incorporates the over-temperature protection and reverse blocking functions.

The SY6863B2 supports USB PD3.0 fast role swap. The output voltage could recovery to USB valid voltage range in 100 μ s during USB PD fast role swap event.

Ordering Information

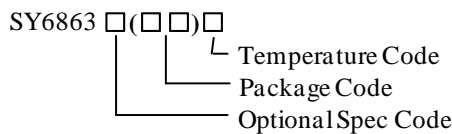

Ordering Number	Package Type	Note
SY6863B2ABC	SOT23-6	Active Low

Features

- Input Voltage: 2.5V to 5.5V
- Output Voltage Withstanding 28V
- Extremely Low Power Path Resistance: 45m Ω (typ.)
- 3A Load Current Capability
- Reverse Blocking in Normal Operation or Shutdown
- Fault Flag (OCB) Output for over Current and Fault Conditions
- Fast Role Swap Support
- Compact Package: SOT23-6
- RoHS Compliant and Halogen Free

Applications

- USB 3.1 Application
- USB 3G Datacard
- USB Dongle
- MiniPCI Accessories
- USB Charger
- Public Place Multi-USB Charger

Typical Applications

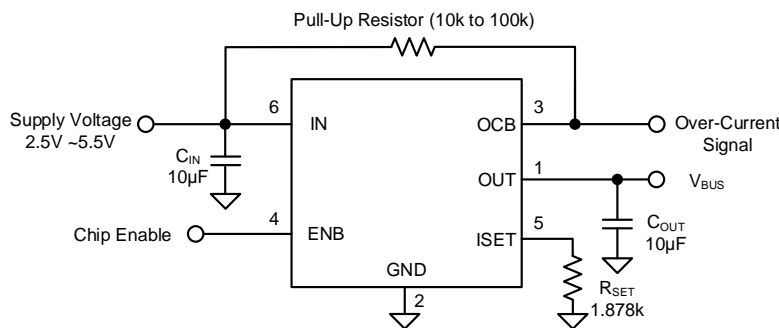

Note: If 1uF input cap will lead to large V_{in} voltage spike, it is strongly recommended to add additional 10uF ceramic cap.

Figure 1. Schematic Diagram

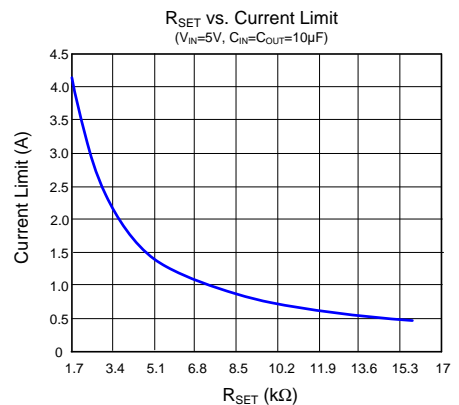
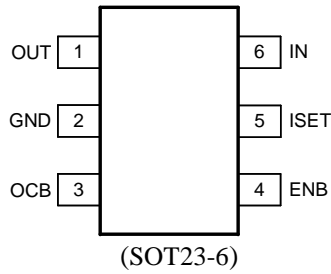

Figure 2. R_{SET} vs. Current Limit

Pinout (top view)



Top Mark: **aBxyz** for SY6863B2ABC (Device code: aB; *x=year code, y=week code, z=lot number code*)

Pin Name	Pin number	Pin Description
	SOT23-6	
OUT	1	Output pin.
GND	2	Ground pin.
OCB	3	Fault Flag. Open drain under normal conditions, grounded under fault operation.
ENB	4	ON/OFF control. Do not leave it floating. ENB: Active low.
IN	6	Input pin.
ISET	5	Current limit programming pin. Connect a resistor R_{SET} from this pin to ground to program the current limit: $I_{LIM} (A) = 7100 / R_{SET} (\Omega)$

Block Diagram

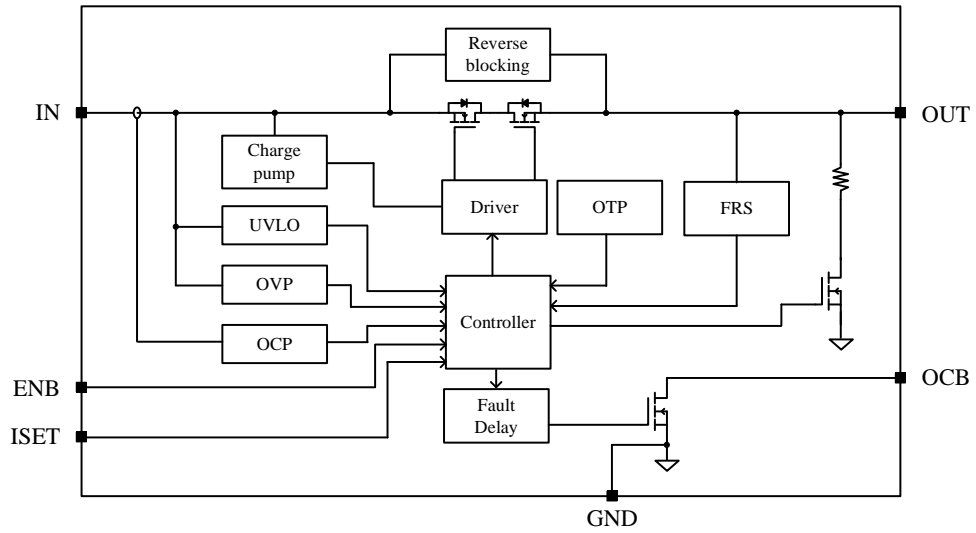

Figure 3. Block Diagram



SY6863B2

Absolute Maximum Ratings (Note 1)

IN	-0.3V to 7V
ISET	-0.3V to 3.6V
OCB, EN, ENB, OUT	-0.3V to 28V
Power Dissipation, P_D @ $T_A = 25^\circ\text{C}$ SOT23-6	1.2W
Package Thermal Resistance (Note 2)	
θ_{JA} , SOT23-6	81°C/W
θ_{JC} , SOT23-6	14°C/W
Junction Temperature Range	-40°C to 150°C
Lead Temperature (Soldering, 10 sec.)	260°C
Storage Temperature Range	-65°C to 150°C
ESD Susceptibility	
HBM (Human Body Mode)	2kV
CDM (Charged Device Mode)	500V

Recommended Operating Conditions (Note 3)

IN	2.5V to 5.5V
ISET	0V to 3.3V
All other pins	0V to 22V
Junction Temperature Range	-40°C to 125°C
Ambient Temperature Range	-40°C to 85°C



Electrical Characteristics

($V_{IN} = 5V$, $C_{OUT} = 10\mu F$, $T_A = 25^\circ C$ unless otherwise specified)

Parameter	Symbol	Test Conditions	Min	Typ	Max	Unit
Input Voltage Range	V_{IN}		2.5		5.5	V
Output Over Voltage Protection	V_{OVP}			5.6		V
OVP Hysteresis	V_{OVP_HYS}			0.1		V
Shutdown Input Current	I_{SHDN}	Open load, switch OFF		5	30	μA
		Output grounded, switch OFF		5	30	μA
Quiescent Supply Current	I_Q	Open load, switch ON		65		μA
FET $R_{DS(ON)}$	$R_{DS(ON)}$	$V_{IN} = 5V$ $I_{OUT} = 0.5A$		45	50	m Ω
Current Limit	I_{LIM}	$R_{SET} = 1.878k$, $V_{IN} = 5V$, $V_{OUT} = 4.75V$	3.0	3.62	4.16	
Programmable Current Limit Range	I_{LIM_RANGE}		0.4		4	A
EN/ \overline{EN} Threshold	Logic-Low Voltage	V_{IL}			0.4	V
	Logic-High Voltage	V_{IH}	1.0			V
IN UVLO Threshold	V_{IN_UVLO}				2.45	V
IN UVLO Hysteresis	V_{IN_HYS}			0.1		V
Rise Time	t_{RISE}	$V_{IN} = 3.3V$, $R_L = 10\Omega$, $C_L = 1\mu F$	1.0	1.9	3.0	ms
		$V_{IN} = 5.0V$, $R_L = 10\Omega$, $C_L = 1\mu F$	1.5	3.0	4.5	ms
OCB Low Resistance	R_{OCB}			125		Ω
OCB Delay Time	t_{OCB_Delay}			15		ms
OUT Shutdown Discharge Resistance	R_{DSG}		90	115	140	Ω
Discharge Time	t_{DSG}			130		ms
Fast Role Swap Response	t_{FRS}	From V_{OUT} drops below 4.75V to V_{OUT} back to 4.75V		100		μs
Thermal Shutdown Temperature	T_{SD}			150		$^\circ C$
Thermal Shutdown Hysteresis	T_{HYS}			20		$^\circ C$

Note 1: Stresses beyond the “Absolute Maximum Ratings” may cause permanent damage to the device. These are stress ratings only. Functional operation of the device at these or any other conditions beyond those indicated in the operational sections of the specification is not implied. Exposure to absolute maximum rating conditions for extended periods may affect device reliability.

Note 2: θ_{JA} is measured in the natural convection at $T_A = 25^\circ C$ on a Silergy’s test board. Pin 2 of SOT23-6 package is the case position for θ_{JC} measurement.

Note 3: The device is not guaranteed to function outside its operating conditions.

Typical Performance Characteristic

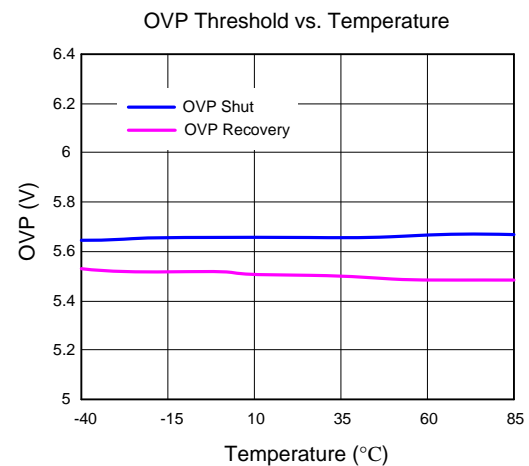
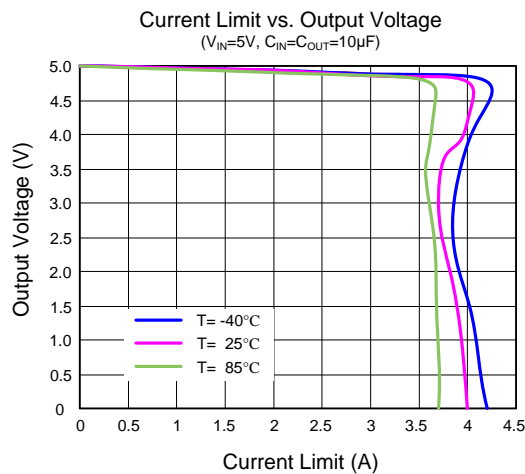
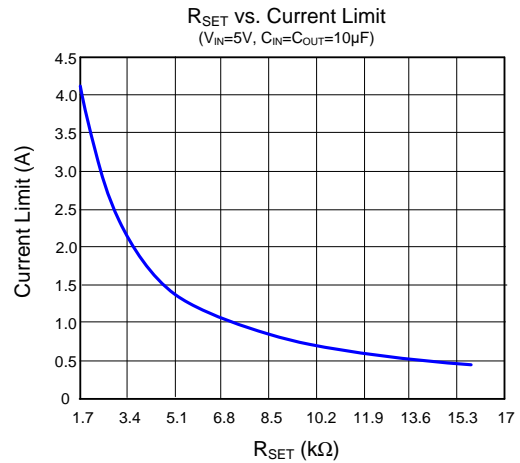
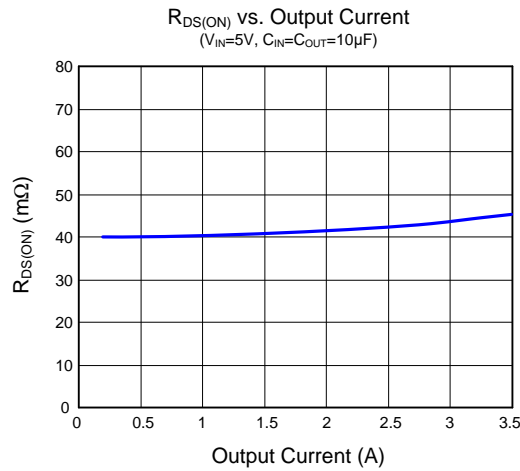
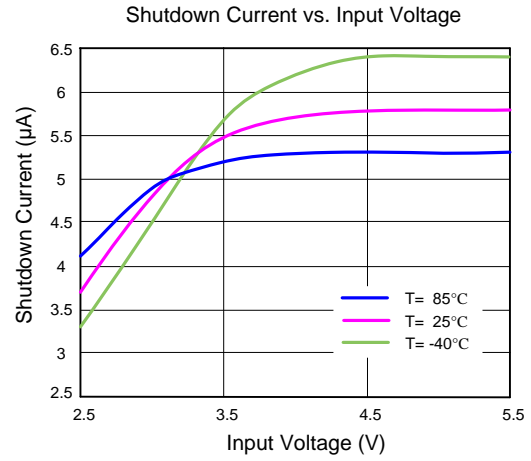
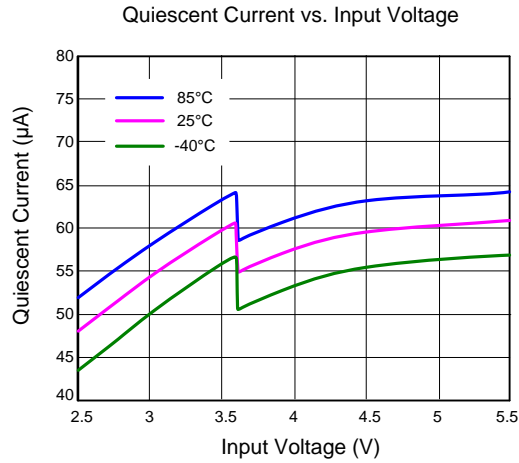

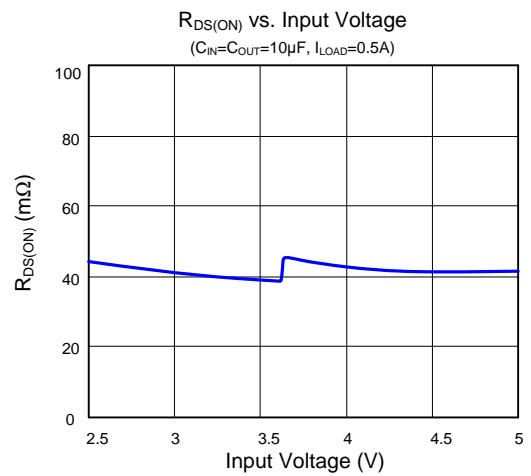
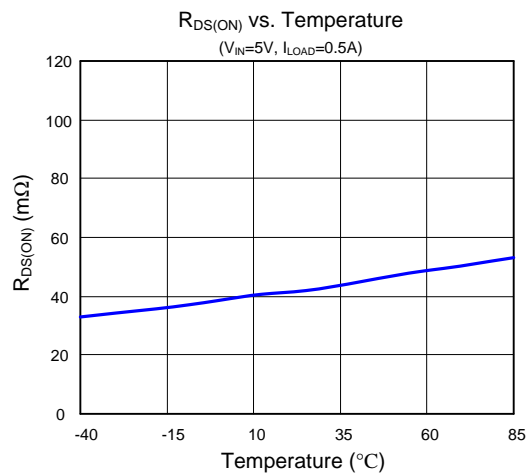
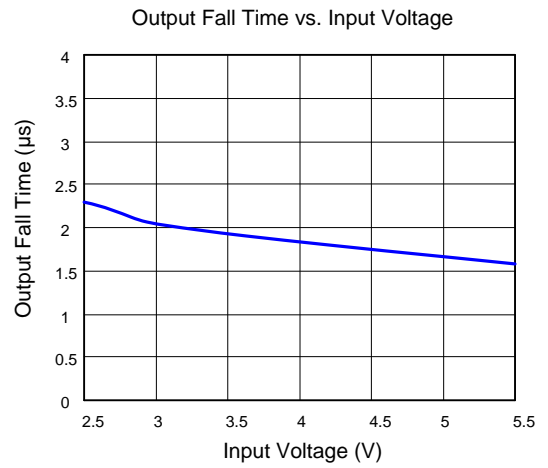
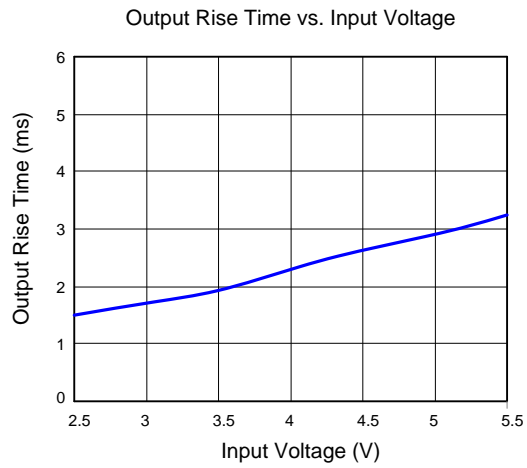
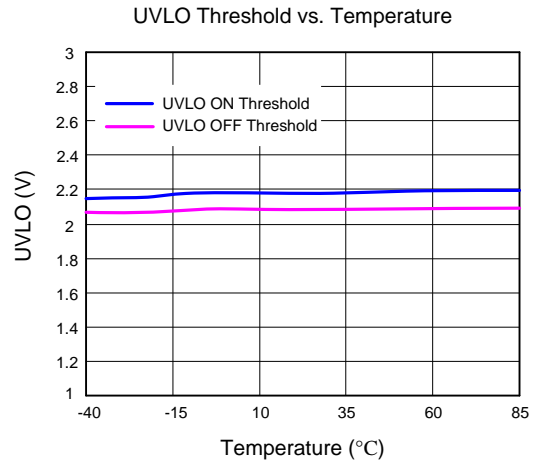
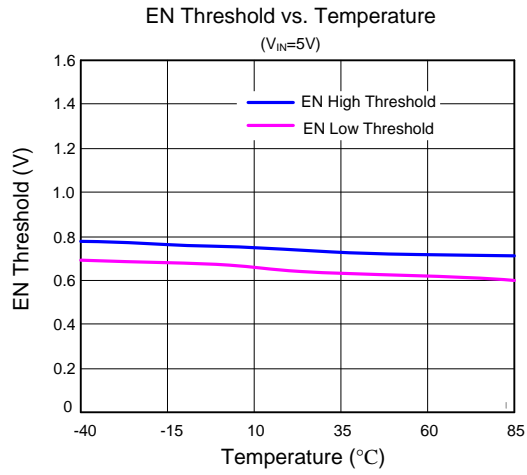

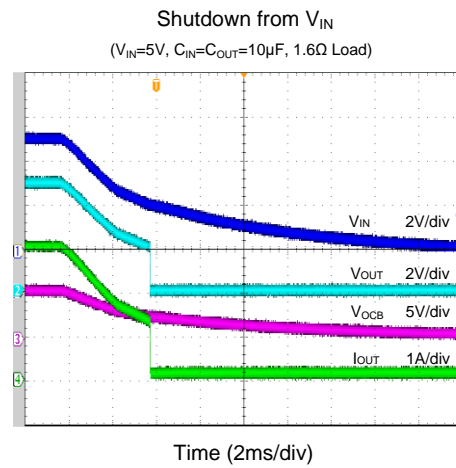
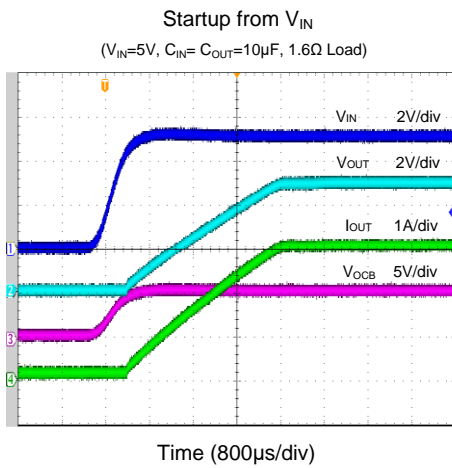
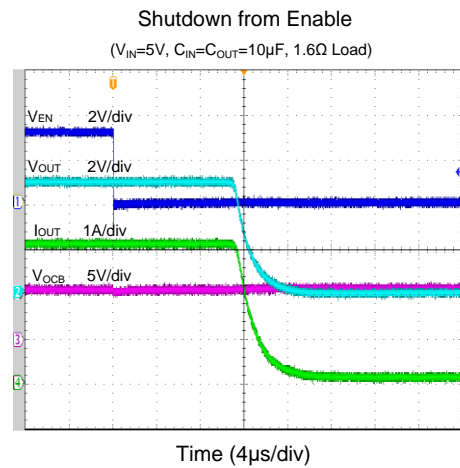
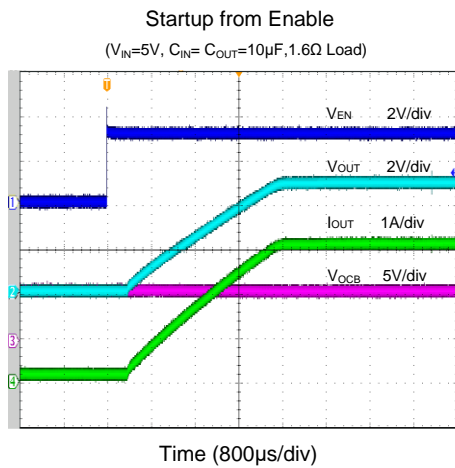
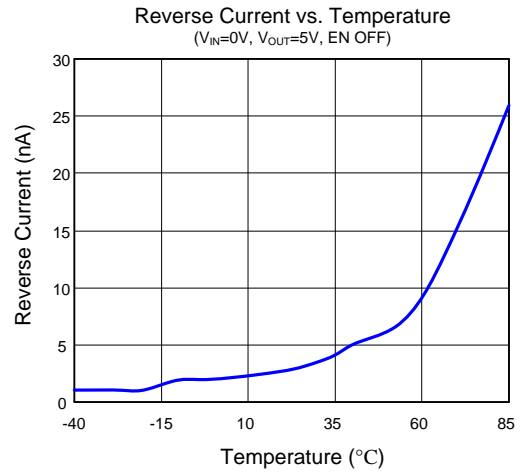
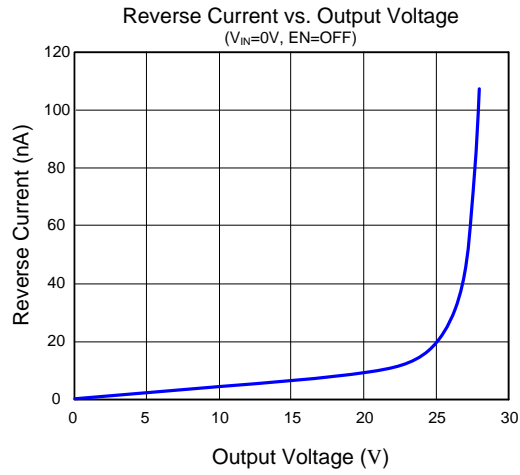

Turn off Delay Time and Fall Time

($V_{IN}=5V$, $R_L=10\Omega$, $C_{IN}=C_{OUT}=10\mu F$)

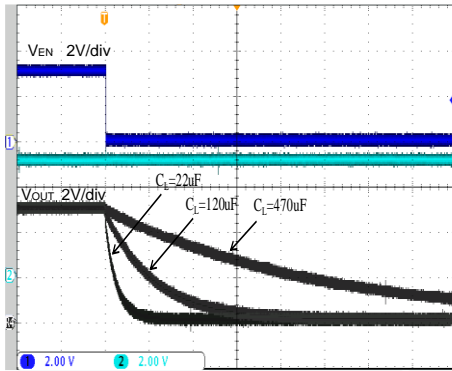

Time (2ms/div)

Inrush Current with Different Load Capacitance

($V_{IN}=5V$, $C_{IN}=C_{OUT}=10\mu F$, $C_L=470\mu F$, $R_L=10\Omega$)

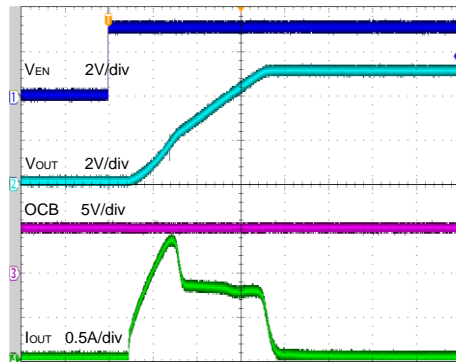

Time (800 μs /div)

Capacitance Load Inrush Response

($V_{IN}=5V$, $C_{IN}=C_{OUT}=10\mu F$, $R_L=10\Omega$, 470 μF plug in)

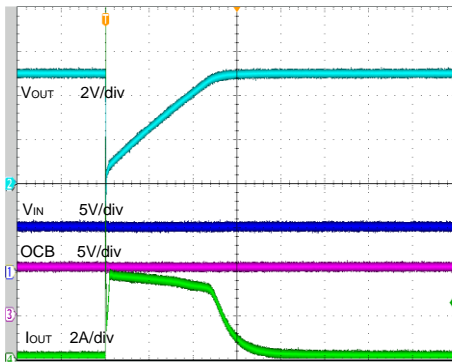

Time (200 μs /div)

Resistance Load Inrush Response

($V_{IN}=5V$, $C_{IN}=C_{OUT}=10\mu F$, $R_L=1.3\Omega$)

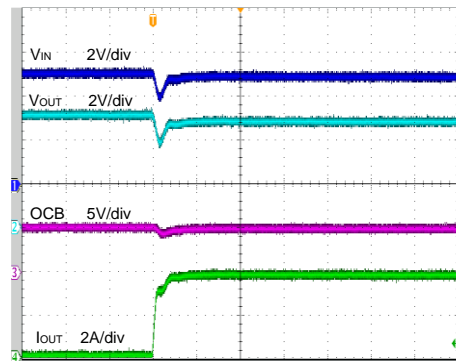

Time (10 μs /div)

Short Circuit Response

($V_{IN}=5V$, $C_{IN}=C_{OUT}=10\mu F$)

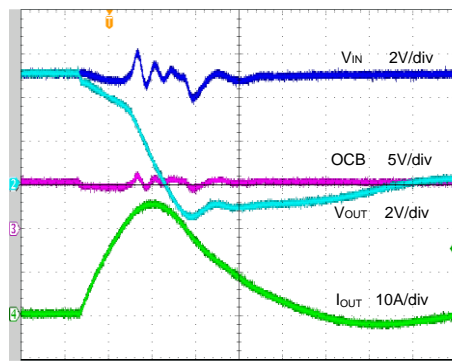

Time (2 μs /div)

Reverse-Voltage Protection Response

($V_{IN}=5.5V \rightarrow 5V$, $V_{OUT}=5.5V$, $C_{IN}=C_{OUT}=10\mu F$)

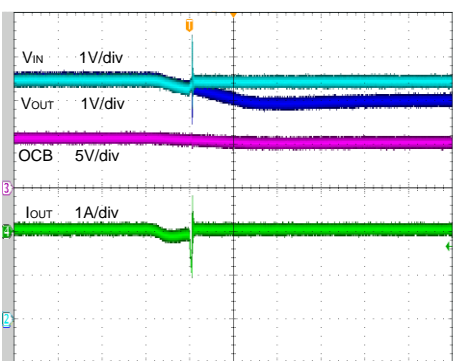

Time (400 μs /div)

Reverse-Voltage Protection Recovery

($V_{IN}=5V$, $C_{IN}=C_{OUT}=10\mu F$, $R_L=10\Omega$, $5.5V$ V_{OUT} Removed)

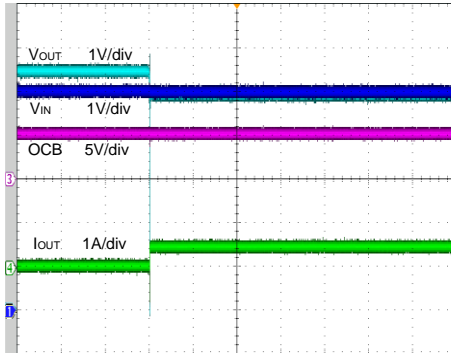

Time (200ms/div)

Thermal Shutdown Response

($V_{IN}=5V$, $C_{IN}=C_{OUT}=10\mu F$, $R_L=1.3\Omega$)

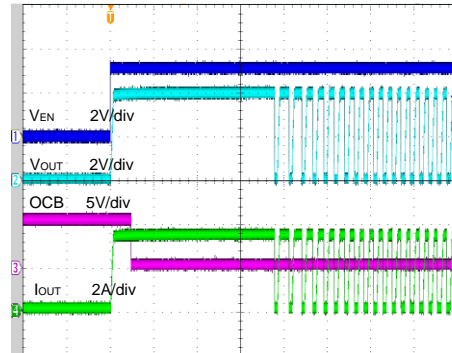

Time (40ms/div)

OCB Response During Over Load

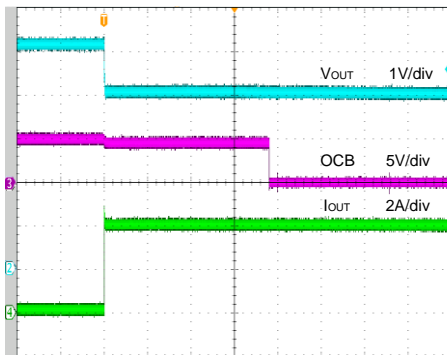

Time (4ms/div)

Fast Role Swap Response

($V_{IN}=5V$, $V_{OUT}=20V$ plug out, $R_{LOAD}=50\Omega$)

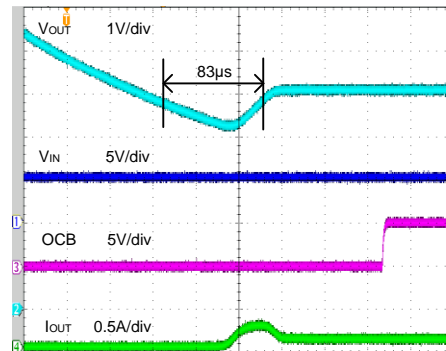

Time (40µs/div)

Operation

The SY6863B2 is a current limited N-channel MOSFET power switch designed for high-side load-switching applications. It incorporates the back to back N-channel MOSFET, so the IC prevents the current-flow from OUT to IN when OUT being externally forced to a higher voltage than IN when the IC is disabled.

Over Current Protection

The SY6863B2 supports current limit programming. Connect a resistor R_{SET} from ISET pin to ground to program the current limit:

$$I_{LIM}(A) = 7100/R_{SET}(\Omega)$$

The minimum current limit is 0.4A. A current limit beyond 4A is not recommended.

When the over-current condition is sensed, the gate of the pass switch is modulated to achieve constant output current. If the over current condition persists for a long time, the junction temperature may exceed 150°C, and over-temperature protection will shut down the part. Once the chip temperature drops below 130°C, the part will restart.

Fault Flag(OCB)

The OCB output is asserted (active low) when input OVP or thermal shutdown protection is triggered or over current condition persists for 15ms. The output remains asserted until fault condition is removed. Connecting a heavy capacitance load to an enabled device can cause a momentary over current condition. However, no false reporting on OCB occurs due to 15ms deglitch circuit.

Over Voltage Protection

The SY6863B2 integrates over voltage protection for the input pin. When the IC is in the ON state and the V_{IN} exceeds 5.6V (typ.), the power FET will be turned off to protect low voltage input stage during the output voltage is higher than 5.6V (typ.). Meanwhile OCB is pulled low to indicate fault condition. Once the output voltage is lower than the input voltage, the power FET will be turned on and OCB is released to high impedance.

Fast Role Swap

The SY6863B2 integrates the fast role swap function, which makes V_{OUT} recovery to 4.75V in 100µs during

V_{OUT} drops from high voltage to low. When EN is high, V_{IN} is valid and V_{OUT} is higher than V_{IN} , the device works at reverse block mode, power FET is off and standby for FRS. Once V_{OUT} drops lower than V_{IN} , power FET will be turned on in 150µs.

Supply Filter Capacitor

In order to prevent the input voltage drooping during hot-plug events, a 1µF ceramic capacitor from V_{IN} to GND is strongly recommended. However, higher capacitor values could reduce the voltage droop on the input further. Furthermore, an output short will cause ringing on the input without the input capacitor. It could destroy the internal circuitry when the input transient exceeds the absolute maximum supply voltage even for a short duration.

Output Filter Capacitor

A 10µF output ceramic capacitor is recommended to be placed close to the IC and output connector to reduce voltage drop during load transient. Some illegal USB PD device will provide 20V bus voltage without USB negotiation. Therefore the output capacitor should be larger than 4.7µF to decouple the large spike when unstandardized USB PD device plug in. The SY6863B2 is guaranteed to be safe from damage with OUT voltage up to 28V. Nevertheless, voltage transient above 28V may cause permanent damage. A TVS is recommended to clamp the voltage spike.

Reverse block Function

The SY6863B2 integrates reverse block function. Once the deviation voltage of OUT-IN exceeds 60mV, the reverse block is triggered. The power FET will be shutdown in 600ns to block the reverse current flow from OUT to IN.

PCB Layout Guide

For the best performance of the SY6863B2, the following guidelines must be strictly followed:

1. Keep all VBUS traces as short and wide as possible and use at least 2 ounce copper for all VBUS traces.
2. Locate the output capacitor as close to the connectors as possible to lower the impedance (mainly inductance) between the port and the capacitor to improve transient performance.
3. Input and output capacitors should be placed closed to the IC and connected to ground plane to reduce the noise coupling.

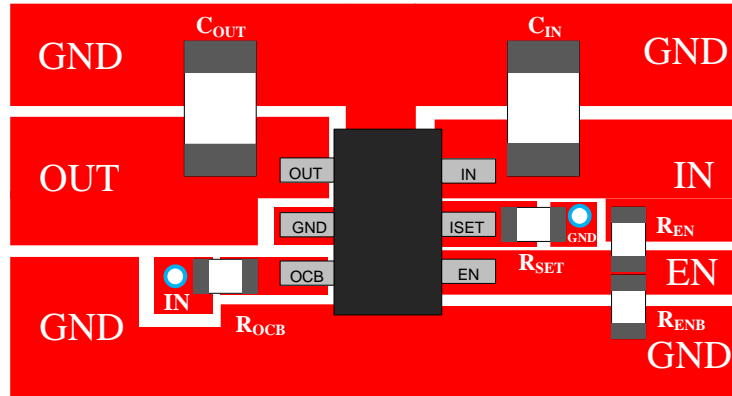
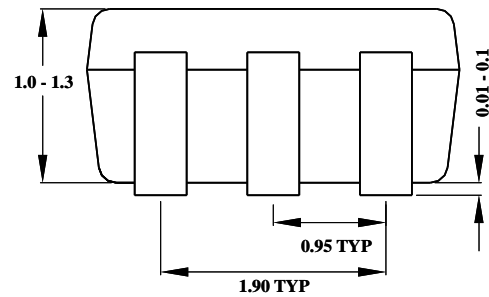
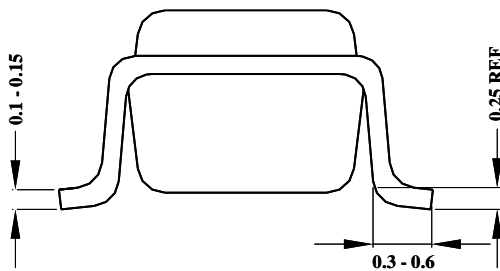
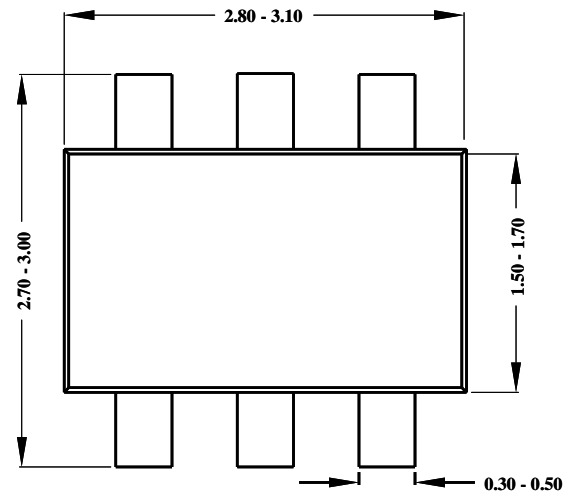
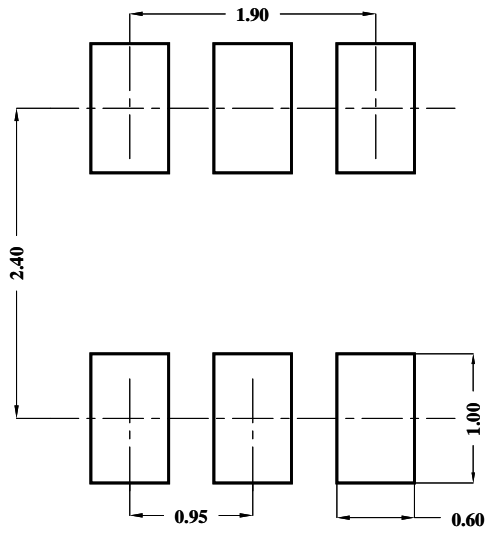

Figure 4. PCB Layout Suggestion

SOT23-6 Package outline & PCB layout design



Notes: All dimensions are in millimeters.
 All dimensions don't include mold flash & metal burr.

Taping & Reel Specification

1. Taping orientation

SOT23-6

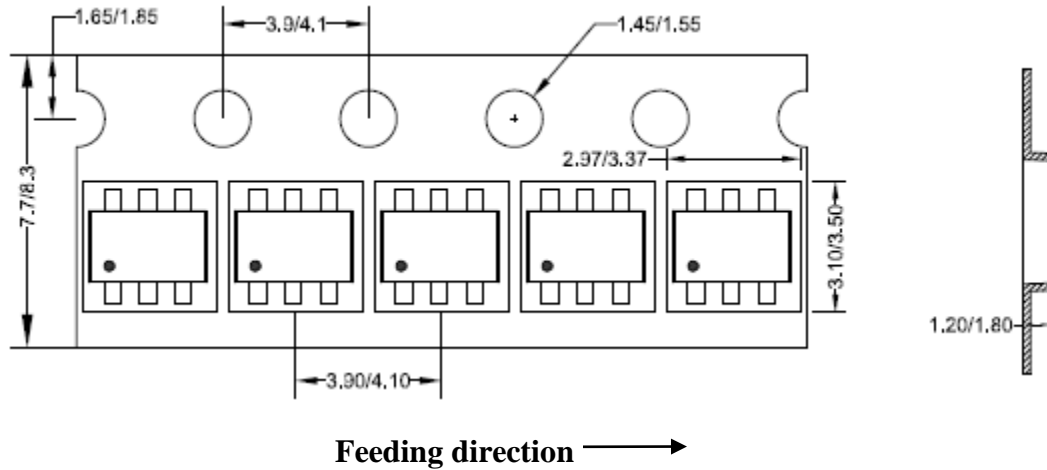

2. Carrier Tape & Reel specification for packages

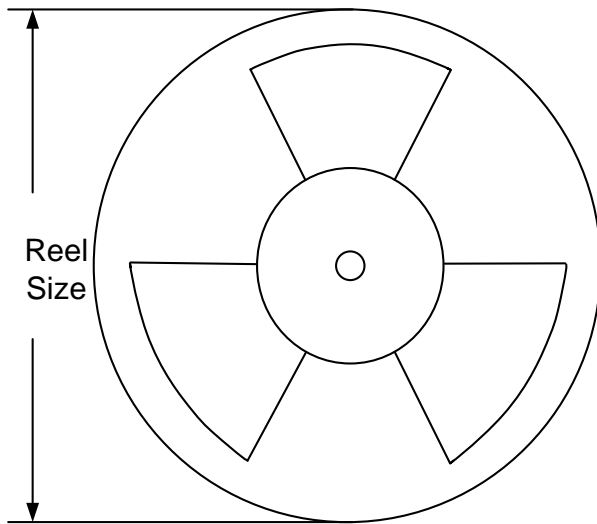

Package type	Tape width (mm)	Pocket pitch(mm)	Reel size (Inch)	Trailer length(mm)	Leader length (mm)	Qty per reel
SOT23-6	8	4	7"	280	160	3000

3. Others: NA

**IMPORTANT NOTICE**

1. **Right to make changes.** Silergy and its subsidiaries (hereafter Silergy) reserve the right to change any information published in this document, including but not limited to circuitry, specification and/or product design, manufacturing or descriptions, at any time and without notice. This document supersedes and replaces all information supplied prior to the publication hereof. Buyers should obtain the latest relevant information before placing orders and should verify that such information is current and complete. All semiconductor products are sold subject to Silergy's standard terms and conditions of sale.
2. **Applications.** Application examples that are described herein for any of these products are for illustrative purposes only. Silergy makes no representation or warranty that such applications will be suitable for the specified use without further testing or modification. Buyers are responsible for the design and operation of their applications and products using Silergy products. Silergy or its subsidiaries assume no liability for any application assistance or designs of customer products. It is customer's sole responsibility to determine whether the Silergy product is suitable and fit for the customer's applications and products planned. To minimize the risks associated with customer's products and applications, customer should provide adequate design and operating safeguards. Customer represents and agrees that it has all the necessary expertise to create and implement safeguards which anticipate dangerous consequences of failures, monitor failures and their consequences, lessen the likelihood of failures that might cause harm and take appropriate remedial actions. Silergy assumes no liability related to any default, damage, costs or problem in the customer's applications or products, or the application or use by customer's third-party buyers. Customer will fully indemnify Silergy, its subsidiaries, and their representatives against any damages arising out of the use of any Silergy components in safety-critical applications. It is also buyers' sole responsibility to warrant and guarantee that any intellectual property rights of a third party are not infringed upon when integrating Silergy products into any application. Silergy assumes no responsibility for any said applications or for any use of any circuitry other than circuitry entirely embodied in a Silergy product.
3. **Limited warranty and liability.** Information furnished by Silergy in this document is believed to be accurate and reliable. However, Silergy makes no representation or warranty, expressed or implied, as to the accuracy or completeness of such information and shall have no liability for the consequences of use of such information. In no event shall Silergy be liable for any indirect, incidental, punitive, special or consequential damages, including but not limited to lost profits, lost savings, business interruption, costs related to the removal or replacement of any products or rework charges, whether or not such damages are based on tort or negligence, warranty, breach of contract or any other legal theory. Notwithstanding any damages that customer might incur for any reason whatsoever, Silergy' aggregate and cumulative liability towards customer for the products described herein shall be limited in accordance with the Standard Terms and Conditions of Sale of Silergy.
4. **Suitability for use.** Customer acknowledges and agrees that it is solely responsible for compliance with all legal, regulatory and safety-related requirements concerning its products, and any use of Silergy components in its applications, notwithstanding any applications-related information or support that may be provided by Silergy. Silergy products are not designed, authorized or warranted to be suitable for use in life support, life-critical or safety-critical systems or equipment, nor in applications where failure or malfunction of a Silergy product can reasonably be expected to result in personal injury, death or severe property or environmental damage. Silergy assumes no liability for inclusion and/or use of Silergy products in such equipment or applications and therefore such inclusion and/or use is at the customer's own risk.
5. **Terms and conditions of commercial sale.** Silergy products are sold subject to the standard terms and conditions of commercial sale, as published at <http://www.silergy.com/stdterms>, unless otherwise agreed in a valid written individual agreement specifically agreed to in writing by an authorized officer of Silergy. In case an individual agreement is concluded only the terms and conditions of the respective agreement shall apply. Silergy hereby expressly objects to and denies the application of any customer's general terms and conditions with regard to the purchase of Silergy products by the customer.
6. **No offer to sell or license.** Nothing in this document may be interpreted or construed as an offer to sell products that is open for acceptance or the grant, conveyance or implication of any license under any copyrights, patents or other industrial or intellectual property rights. Silergy makes no representation or warranty that any license, either express or implied, is granted under any patent right, copyright, mask work right, or other intellectual property right. Information published by Silergy regarding third-party products or services does not constitute a license to use such products or services or a warranty or endorsement thereof. Use of such information may require a license from a third party under the patents or other intellectual property of the third party, or a license from Silergy under the patents or other intellectual property of Silergy.

For more information, please visit: www.silergy.com

©2021 Silergy Corp.

All Rights Reserved.