

General Description

SY22312-H2 combines a photodiode and a current-to-frequency converter circuit on a single chip. Its output is a square wave (50% duty cycle) with frequency proportional to light intensity on the photodiode. This digital output allows direct interface to a microcontroller or other logic circuitry. The device has been temperature compensated for the ultraviolet-to-visible light range of 320 nm to 700 nm and can respond over the light range of 320 nm to 1050 nm.

SY22312-H2 is characterized for operation over the temperature range of -40°C to 85°C and is supplied in a compact side-looker package.

Features

- High-resolution Conversion of Light Intensity to Frequency without External Components
- Low Dark Frequency <1Hz at 50°C
- Single-supply Operation 2.7V to 3.6V
- Interfaces Directly to a Microcontroller
- RoHS Compliant

Application Schematic

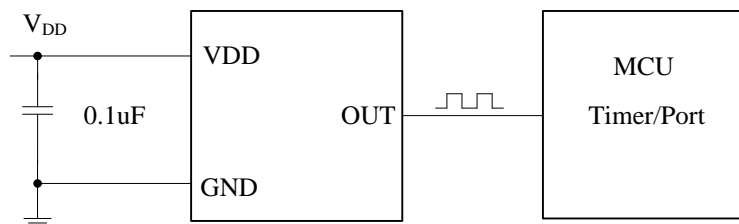

Figure 1. Typical Application

Pin Assignment

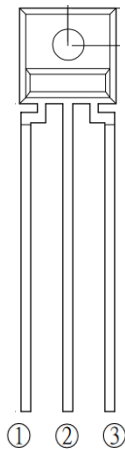

Figure 2. Pin-out

Pin Name	Pin number	Descriptions
GND	1	Power ground pin
VDD	2	Power supply input
OUT	3	Output frequency

Absolute Maximum Ratings [Note 1]($T_A=25^{\circ}\text{C}$ unless otherwise specified)

Symbol	Parameter	Min	Max	Unit
V_{DD}	Supply Input Voltage		6	V
T_{STG}	Storage Temperature	-40	+85	$^{\circ}\text{C}$
ESD	Human Body Mode	±2000		V
	Machine Mode	±500		V

Recommended Operating Conditions ($T_A=25^{\circ}\text{C}$ unless otherwise specified)

Symbol	Parameter	Min	Typ	Max	Unit
V_{DD}	Supply Input Voltage	2.7		3.6	V
T_{OPR}	Operating temperature	-40		+85	$^{\circ}\text{C}$

Block Diagram

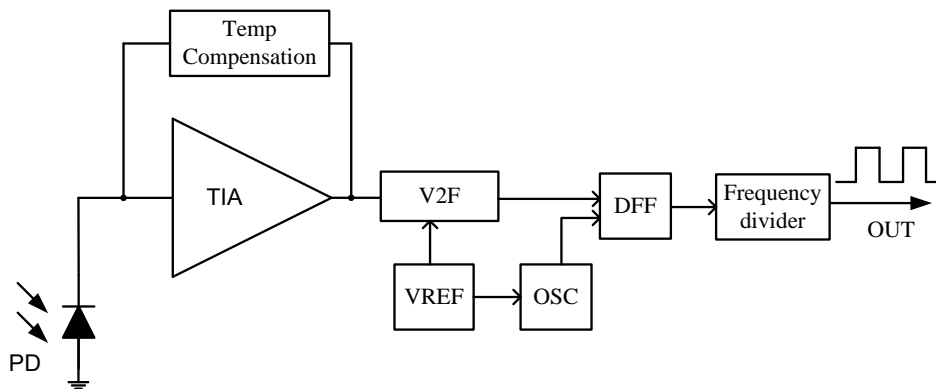

Figure 3. Function Block Diagram

Electrical Characteristics

($V_{DD} = 3.3V$, $T_A = 25^\circ C$, unless otherwise specified)

Parameter	Symbol	Test Conditions	Min	Typ	Max	Unit
Supply Input Voltage	V_{DD}		2.7		3.6	V
High-level Output Voltage	V_{OH}	$I_{OH} = -1 \text{ mA}$	2.3	3		V
Low-level Output Voltage	V_{OL}	$I_{OL} = 1 \text{ mA}$		0.1	0.4	V
Supply Current	I_{DD}			1	1.5	mA
Full-scale Frequency [Note2]			800	1000		kHz
Power Supply Suppression Ratio of Frequency Output	PSSR	$V_{DD} = 3.3V \pm 10\%$	-1		1	%/V

Operating Characteristics

($V_{DD} = 3.3V$, $T_A = 25^\circ C$, $\lambda_p = 660 \text{ nm}$, unless otherwise specified)

Parameter	Symbol	Test Conditions	Min	Typ	Max	Unit
Output Frequency	f_O	$E_e = 18.1 \text{ uW/cm}^2$	40	50	60	kHz
Dark Frequency	f_D	$E_e = 0 \text{ uW/cm}^2$	0	0.1		Hz
Frequency Transfer Ratio	FTR			2.76		kHz/(uW/cm ²)
Nonlinearity [Note3]		$f_O = 0 \text{ kHz to } 10 \text{ kHz}$		$\pm 1\%$		%F.S.

Note 1: Stresses beyond the “Absolute Maximum Ratings” may cause permanent damage to the device. These are stress ratings only. Functional operation of the device at these or any other conditions beyond those indicated in the operational sections of the specification is not implied. Exposure to absolute maximum rating conditions for extended periods may affect device reliability.

Note 2: Full-scale frequency is the maximum operating frequency of the device without saturation.

Note 3: Nonlinearity is defined as the deviation of f_O from a straight line between zero and full scale, expressed as a percent of full scale.

Operation Principles

When exposed at light, the photodiode can generate a current which flows through TIA (trans-impedance amplifier), and the voltage output of TIA is transferred into a frequency output proportionally. The OSC is used to align the frequency output by DFF gating, and the gating pulse is also fed into a frequency divider to generate a 50% duty cycle square wave.

Light current that PD generates is proportional to light intensity, so the higher light intensity on SY22312-H2 surface, the higher frequency will be given at the OUT terminal.

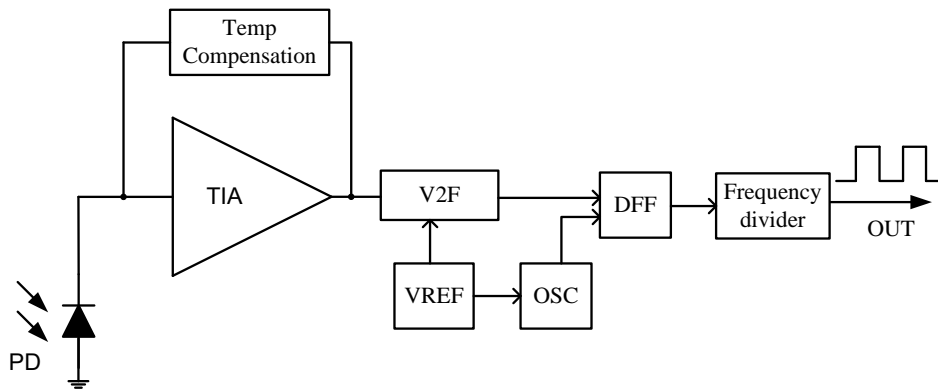

Power Supply Consideration

A typical capacitor with 0.1uF~1uF capacitance is recommended to place close to SY22312-H2 to decouple power line noise.

Output Interface

Output terminal of SY22312-H2 is designed to drive a CMOS logic input through short distances. For most applications, we can directly connect its output terminal to input pin of microcontroller. A buffer is recommended if the routing length between SY22312-H2 and microcontroller is longer than 250 mm.

Typical Characteristic Curves

Relative Spectral Response

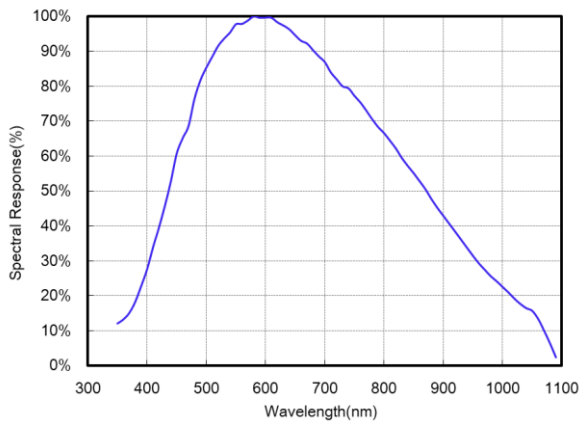

Output Frequency vs. Irradiance

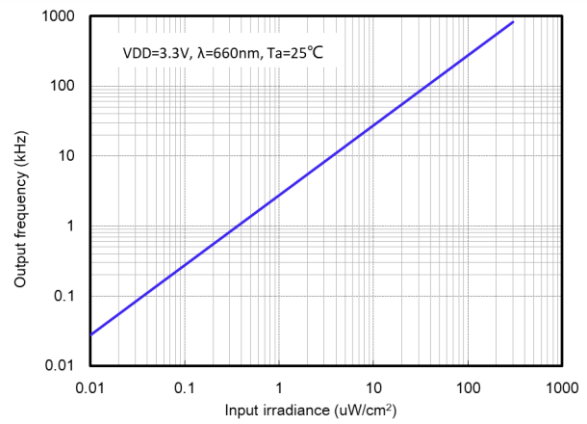

Current Consumption vs. Ambient Temperature

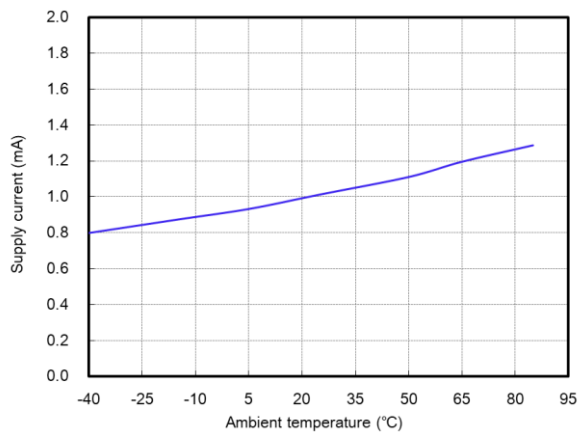

Dark Frequency vs. Ambient Temperature

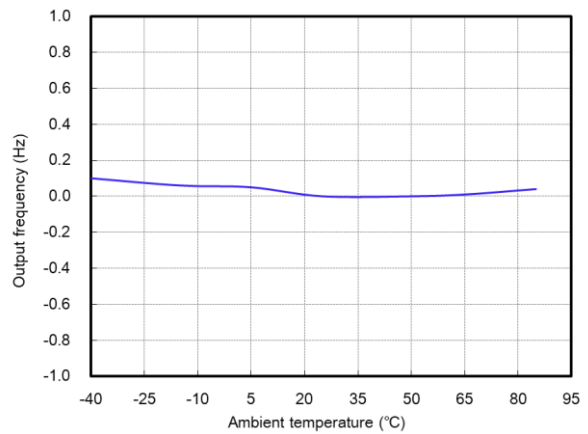

Output Frequency vs. Angular Displacement

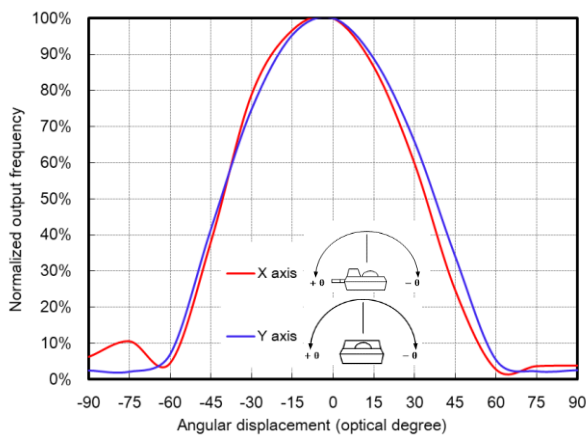



Package Information

SY22312-H2 is supplied in a clear plastic three-lead through-hole package.

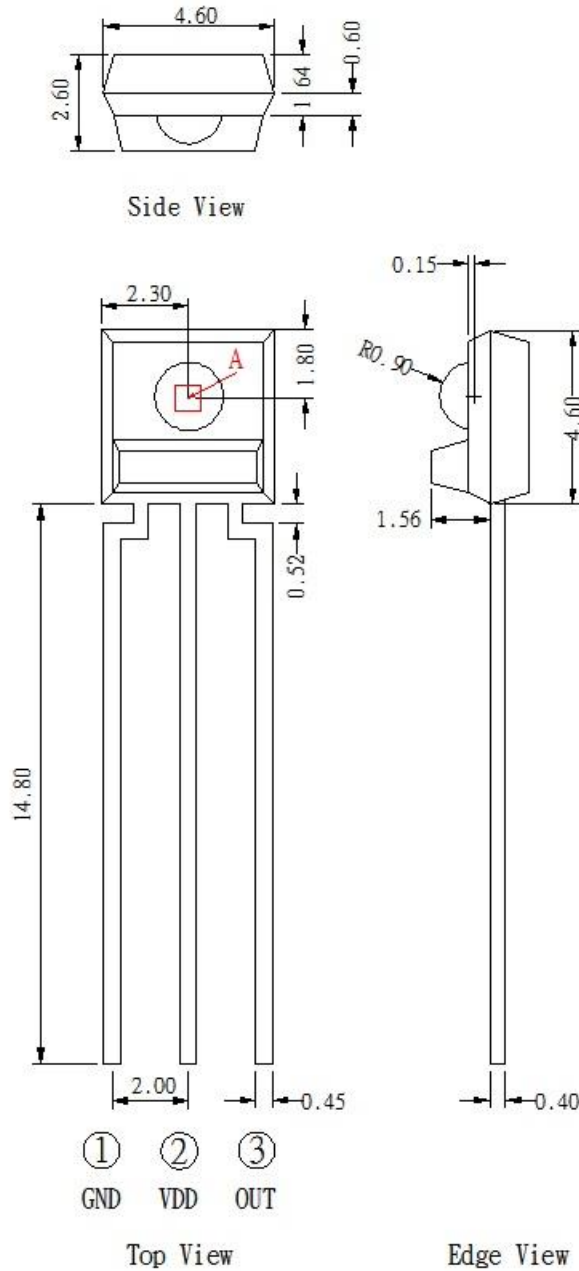

Notes:

- [1]. Unit is in mm; all tolerances are ± 0.1 mm unless otherwise noted.
- [2]. Photodiode center is at point A (x,y) = (2.30, 1.80).
- [3]. The photodiode active area is located 1.22mm below the top of the lens surface.

Revision History

The revision history provided is for informational purposes only and is believed to be accurate; however, not warranted. Please make sure that you have the latest revision.

Revision Number	Revision Date	Description
Rev 0.9	Oct. 19, 2020	Initial Release
Rev 1.0	Oct. 19, 2021	Production Release

IMPORTANT NOTICE

- 1. Right to make changes.** Silergy and its subsidiaries (hereafter Silergy) reserve the right to change any information published in this document, including but not limited to circuitry, specification and/or product design, manufacturing or descriptions, at any time and without notice. This document supersedes and replaces all information supplied prior to the publication hereof. Buyers should obtain the latest relevant information before placing orders and should verify that such information is current and complete. All semiconductor products are sold subject to Silergy's standard terms and conditions of sale.
- 2. Applications.** Application examples that are described herein for any of these products are for illustrative purposes only. Silergy makes no representation or warranty that such applications will be suitable for the specified use without further testing or modification. Buyers are responsible for the design and operation of their applications and products using Silergy products. Silergy or its subsidiaries assume no liability for any application assistance or designs of customer products. It is customer's sole responsibility to determine whether the Silergy product is suitable and fit for the customer's applications and products planned. To minimize the risks associated with customer's products and applications, customer should provide adequate design and operating safeguards. Customer represents and agrees that it has all the necessary expertise to create and implement safeguards which anticipate dangerous consequences of failures, monitor failures and their consequences, lessen the likelihood of failures that might cause harm and take appropriate remedial actions. Silergy assumes no liability related to any default, damage, costs or problem in the customer's applications or products, or the application or use by customer's third-party buyers. Customer will fully indemnify Silergy, its subsidiaries, and their representatives against any damages arising out of the use of any Silergy components in safety-critical applications. It is also buyers' sole responsibility to warrant and guarantee that any intellectual property rights of a third party are not infringed upon when integrating Silergy products into any application. Silergy assumes no responsibility for any said applications or for any use of any circuitry other than circuitry entirely embodied in a Silergy product.
- 3. Limited warranty and liability.** Information furnished by Silergy in this document is believed to be accurate and reliable. However, Silergy makes no representation or warranty, expressed or implied, as to the accuracy or completeness of such information and shall have no liability for the consequences of use of such information. In no event shall Silergy be liable for any indirect, incidental, punitive, special or consequential damages, including but not limited to lost profits, lost savings, business interruption, costs related to the removal or replacement of any products or rework charges, whether or not such damages are based on tort or negligence, warranty, breach of contract or any other legal theory. Notwithstanding any damages that customer might incur for any reason whatsoever, Silergy' aggregate and cumulative liability towards customer for the products described herein shall be limited in accordance with the Standard Terms and Conditions of Sale of Silergy.
- 4. Suitability for use.** Customer acknowledges and agrees that it is solely responsible for compliance with all legal, regulatory and safety-related requirements concerning its products, and any use of Silergy components in its applications, notwithstanding any applications-related information or support that may be provided by Silergy. Silergy products are not designed, authorized or warranted to be suitable for use in life support, life-critical or safety-critical systems or equipment, nor in applications where failure or malfunction of an Silergy product can reasonably be expected to result in personal injury, death or severe property or environmental damage. Silergy assumes no liability for inclusion and/or use of Silergy products in such equipment or applications and therefore such inclusion and/or use is at the customer's own risk.
- 5. Terms and conditions of commercial sale.** Silergy products are sold subject to the standard terms and conditions of commercial sale, as published at <http://www.silergy.com/stdterms>, unless otherwise agreed in a valid written individual agreement specifically agreed to in writing by an authorized officer of Silergy. In case an individual agreement is concluded only the terms and conditions of the respective agreement shall apply. Silergy hereby expressly objects to and denies the application of any customer's general terms and conditions with regard to the purchase of Silergy products by the customer.
- 6. No offer to sell or license.** Nothing in this document may be interpreted or construed as an offer to sell products that is open for acceptance or the grant, conveyance or implication of any license under any copyrights, patents or other industrial or intellectual property rights. Silergy makes no representation or warranty that any license, either express or implied, is granted under any patent right, copyright, mask work right, or other intellectual property right. Information published by Silergy regarding third-party products or services does not constitute a license to use such products or services or a warranty or endorsement thereof. Use of such information may require a license from a third party under the patents or other intellectual property of the third party, or a license from Silergy under the patents or other intellectual property of Silergy.

For more information, please visit: www.silergy.com

© 2020 Silergy Corp.

All Rights Reserved.