

General Description

The SY22848 is an AC input Constant Voltage buck regulator. Its target applications are home appliances and auxiliary power supplies.

SY22848 integrates 650V MOSFET to decrease physical volume, adopts HV start-up circuit.

SY22848 adopts multi-off time control to realize quasi constant switching frequency and large duty cycle. It uses peak current mode control and enters burst mode at light load to minimize power dissipation.

SY22848 include OCP, OVP and OTP functions.

Features

- 650V MOSFET Integrated
- High Voltage Start up Circuit Integrated
- 50mW No Load Power Consumption
- Multi-off Time Control
- Minimum External Components
- Over Temperature Protection(OTP)
- Output Over Voltage Protection(OVP)
- Compact Package: DIP8

Applications

- Home Appliances and White Goods
- Auxiliary Power Supplies

Recommended operating output power	
Products	$V_{OUT}=18V$
SY22848	6.5W

Typical Application

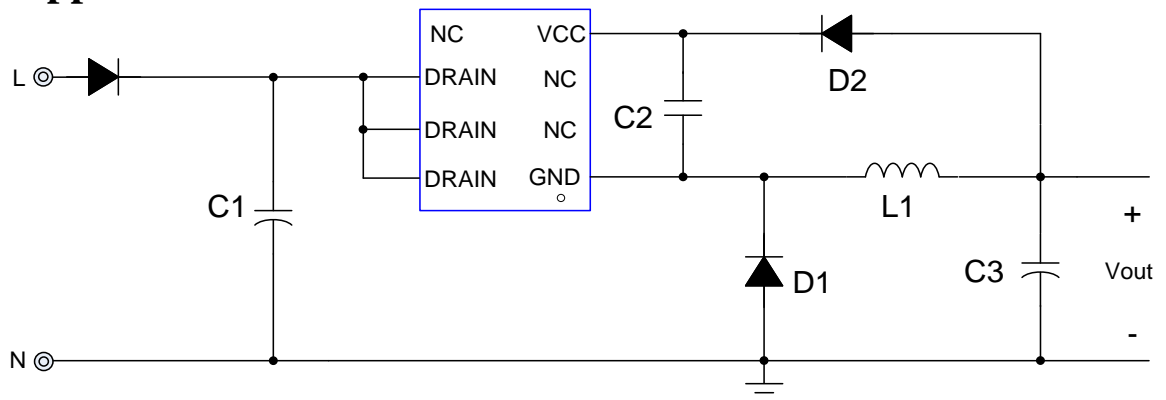
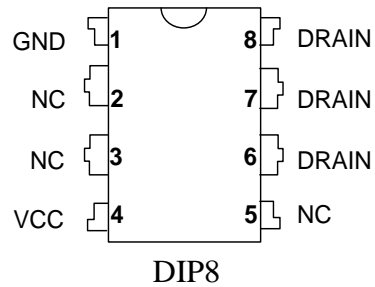
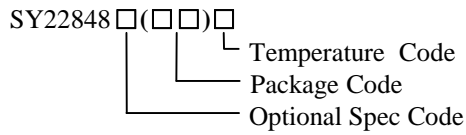

Fig.1 Typical Application Circuit

Ordering Information



Ordering Number	Package	Top Mark
SY22848AGC	DIP8	CMMxyz

x=year code, y=week code, z= lot number code

Pinout (top view)

Pin number	Pin Name	Pin Description
1	GND	IC ground pin.
2,3	NC	No connection.
4	VCC	Power supply pin and voltage sense pin. Connect a ceramic capacitor between VCC and GND pin.
5	NC	No connection.
6,7,8	DRAIN	Internal power MOSFET drain pin.

Absolute Maximum Ratings (Note 1)

VCC	-0.3V~25V
DRAIN	650V
DRAIN Pulse Current (Pulse=100uS)	1.6A
Power Dissipation, @ T _A = 25°C DIP8	1.5W
Package Thermal Resistance (Note 2)	
DIP8, θ _{JA}	83°C/W
DIP8, θ _{JC}	36°C/W
Maximum Junction Temperature	150°C
Lead Temperature (Soldering, 10 sec.)	260°C
Storage Temperature Range	-65°C to 150°C

Recommended Operating Conditions

VCC	18V
Junction Temperature Range	-40°C to 125°C
Ambient Temperature Range	-40°C to 85°C

Electrical Characteristics

(T_A = 25°C unless otherwise specified)

Parameter	Symbol	Test Conditions	Min	Typ	Max	Unit
Power Supply Section						
VCC Turn-on Threshold	V _{VCC_ON}		10.4	11.2	12	V
VCC Turn-off Threshold	V _{VCC_OFF}		5.5	6	6.5	V
HV Current Source Enable Threshold	V _{VCC_MIN}		6.5	7.0	7.5	V
Start up Current	I _{CHARGE}		1.5	1.9	2.3	mA
Operating Current	I _{VCC}	V _{IN} =373V, I _{OUT} =0.3A, L=900μH	1	2	3	mA
Quiescent Current	I _Q	V _{VCC} =19V	300	440	560	μA
Current Sense Section						
Current Limit	I _{ISEN_LIM}		0.61	0.72	0.83	A
V_{VCC} Control Section						
VCC OVP Voltage Threshold	V _{VCC_OVP}		20	21.6	23	V
VCC Voltage Reference	V _{VCC_REF}		17.5	18	18.5	V
Integrated MOSFET Section						
BV of HV MOSFET	V _{BV}	V _{GS} =0V, I _{DS} =250uA	650			V
MOSFET on Resistance	R _{ON_Q1}	V _{GS} =10V, I _{DS} =1A		9.2	11.5	Ω
Driver Section						
Max ON Time	T _{ON_MAX}		16	24	32	μs
Min ON Time	T _{ON_MIN}		100	350	600	ns
Oscillator Section						
Normal Frequency	F _{Normal}	V _{IN} =127V, I _{OUT} =0.3A, L=900μH	24.8	35.5	46.2	kHz
		V _{IN} =373V, I _{OUT} =0.3A, L=900μH	27.3	39	50.7	kHz
Thermal Section						
Thermal Shutdown Temperature	T _{SD}		135	150	165	°C
Hysteresis to Resume Operating	T _{OTP_HYS}		13	20	27	°C

Note 1: Stresses beyond the “Absolute Maximum Ratings” may cause perm anent damage to the device. These are stress ratings only. Functional operation of the device at these or any other conditions beyond those indicated in the operational sections of the specification is not implied. Exposure to absolute maximum rating conditions for extended periods may affect device reliability.

Note 2: θ_{JA} is measured in the natural convection at T_A = 25°C on a low effective single layer thermal conductivity test board of JEDEC 51-3 thermal measurement standard. Test condition: Device mounted on 2” x 2” FR-4 substrate PCB, 2oz copper, with minimum recommended pad on top layer and thermal vias to bottom layer ground plan

Block Diagram

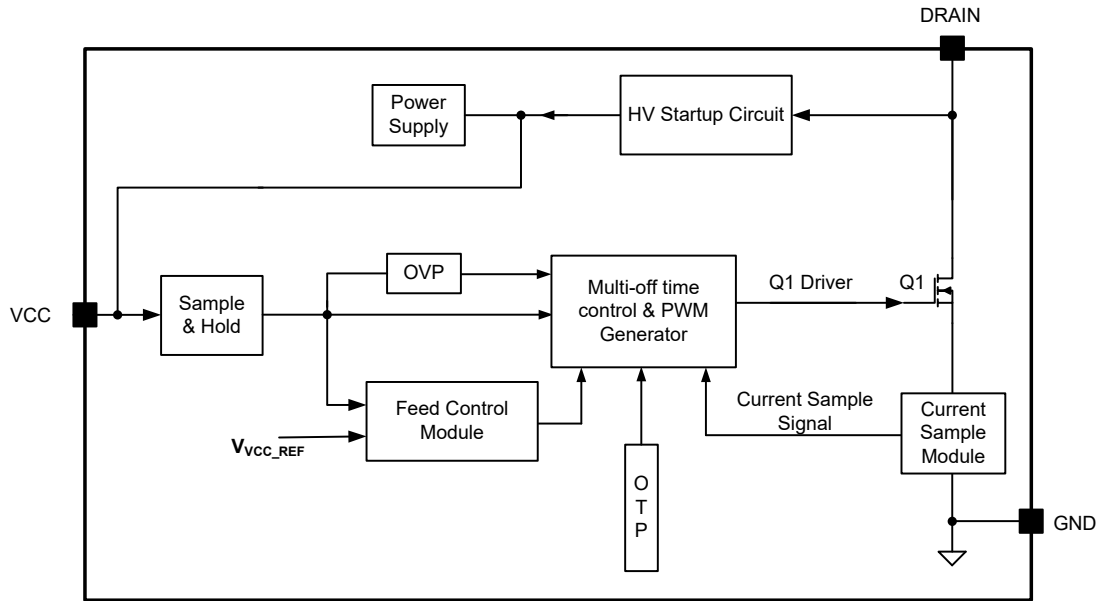
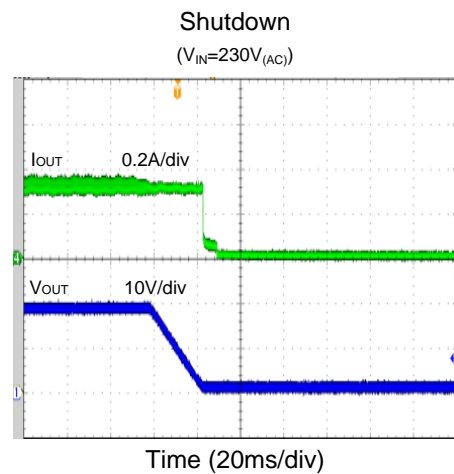
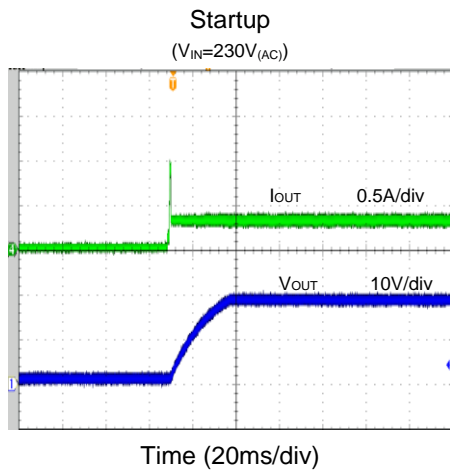
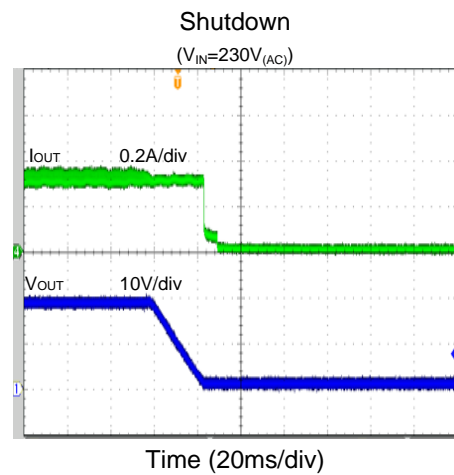
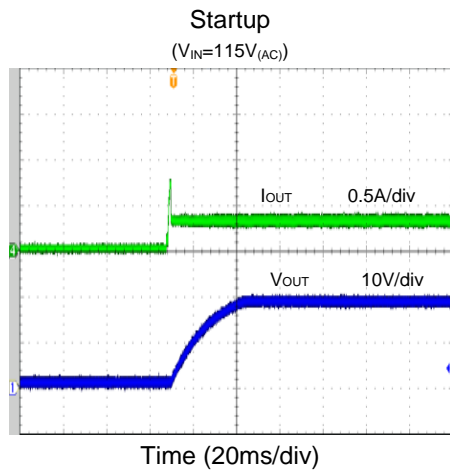
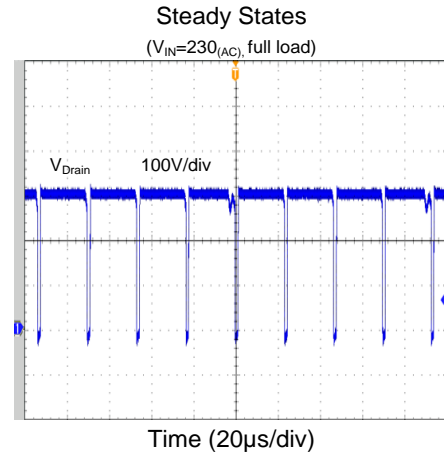
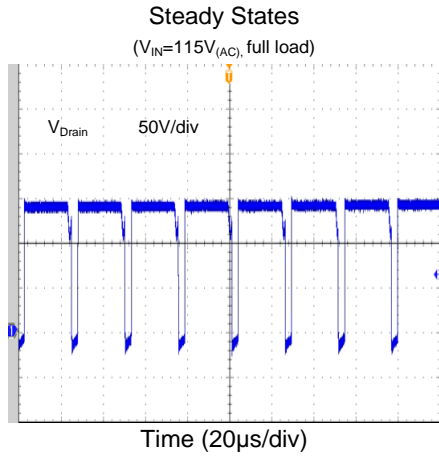
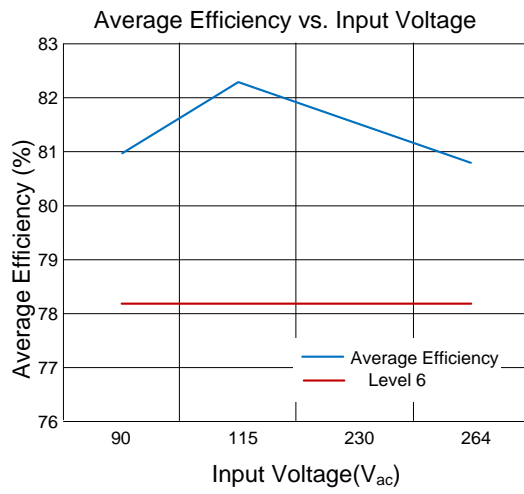
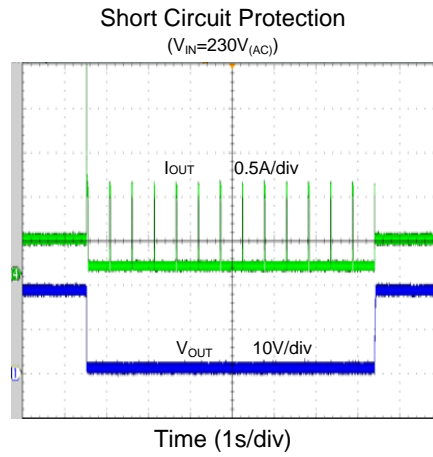
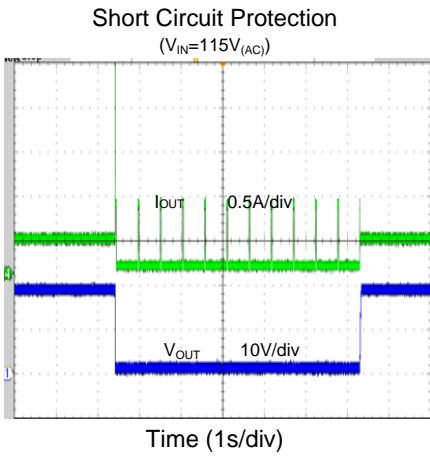

Fig.2 Block diagram

Typical Performance Characteristics

(Test condition: input voltage: 90~264Vac; output spec: 18Vdc_0.36A; Ambient temperature: 25±5 °C; Ambient humidity: 65±25 %.)





Operation Principles

Start-up Operation and Under Voltage Lockout

After AC supply is powered on, the rectified BUS voltage ramps up. The capacitor across VCC and GND pins, C_{VCC}, is charged up by the BUS voltage through an internal HV startup circuit. When VCC voltage reaches V_{VCC_ON}, the IC starts switching and the internal high voltage regulator turns off.

The IC stops switching when the V_{VCC} drops below V_{VCC_MIN}. To reduce the power loss under short circuit condition, SY22848 adopts the smart UVLO strategy. A digital counter is adopted to slow down the restart frequency. If V_{VCC} drop to V_{VCC_MIN}, the internal PWM switching is stop, UVLO flag signal will be set and V_{VCC} will be charged to V_{VCC_ON} again by HV current source. When V_{VCC} has reached V_{VCC_MIN}, the counter will plus 1. Initial number of the counter is 0, and when the counter has reached number 4, UVLO flag signal will be reset, then the V_{VCC} drop to V_{VCC_OFF}. Meanwhile, IC will try to start up with soft start process. The timing diagram is shown as Fig.3.

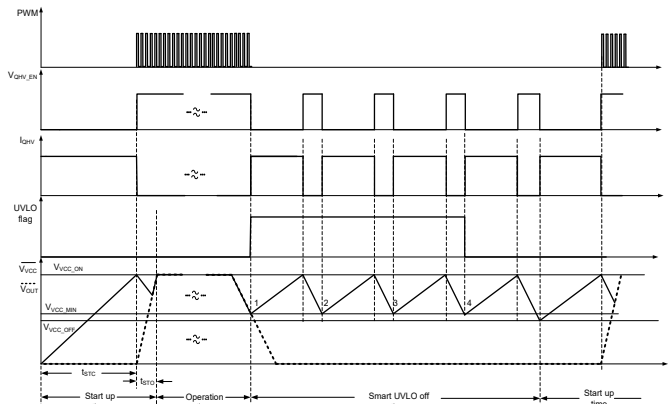

Fig.3 timing diagram of startup and UVLO off

Output Voltage Sample

SY22848 samples the V_{OUT} by V_{Dmain} and V_{Dsample}. The relationship between V_{VCC} and V_{OUT} can be described as: $V_{VCC} = V_{OUT} + V_{Dmain} - V_{Dsample}$

V_{OUT} is the output voltage, V_{Dmain} is the forward voltage drop of the main power diode, V_{Dsample} is the forward voltage drop of the sample diode. The circuit diagram of output voltage feedback is shown in Fig.4.

Generally, forward voltage drop varies with forward current. So V_{Dmain} varies with load current, but V_{Dsample}

keeps constant when load current varies, as a result, V_{VCC} cannot precisely represent V_{OUT}. So SY22848 adopts an internal compensated strategy to optimize the load regulation of V_{OUT}.

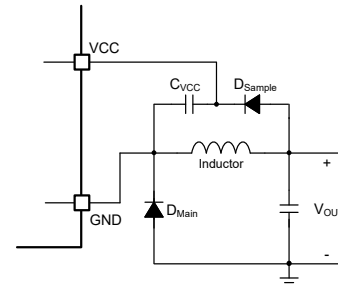

Fig. 4 circuit diagram of output voltage sample

Multi-off time control

SY22848 adopts multi-off time control to achieve quasi constant switching frequency and large duty cycle. Multi-off time control is consist of fix off time control and multi-state control.

The fix off time of PWM is decided by a current source I_i, a capacitor and the reference.

To ensure the switching frequency of circuit is between 28k and 42k, and max duty cycle is above 0.6, multi-state control strategy is adopted. When the T_{on} varies, the T_{off} is changed. The logic diagram is shown in Fig.5.

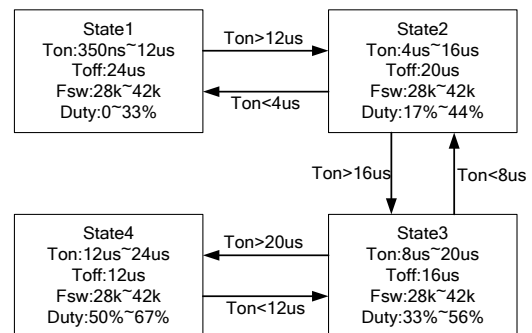

Fig.5 logic diagram of multi-state control

Sleep Mode in Light Load

To improve the light load efficiency, the burst mode control is adopted in SY22848.

As load decreases, the peak current of MOSFET I_{PK} will decrease as well. When I_{PK} falls below a threshold current represented by I_{SLEEP_IN}(typical 1/6 times of I_{ISEN_LIM}), IC will enter sleep mode. Under sleep mode, IC will shut down most of internal circuit to further reduce power consumption by IC.

Due to the closed loop control, I_{PK} will rise again. When I_{PK} rises above a threshold current represented by I_{SLEEP_EXIT} (typical 1/5 times of I_{ISEN_LIM}), IC will exit sleep mode, and resume PWM switching again. The threshold current I_{SLEEP_EXIT} is a little higher than I_{SLEEP_IN} .

To optimize the over voltage protection, the minimum switching frequency will be reduced to 1k, and the peak current will be reduced to I_{SLEEP_IN} . The timing diagram of burst mode is shown in Fig.6.

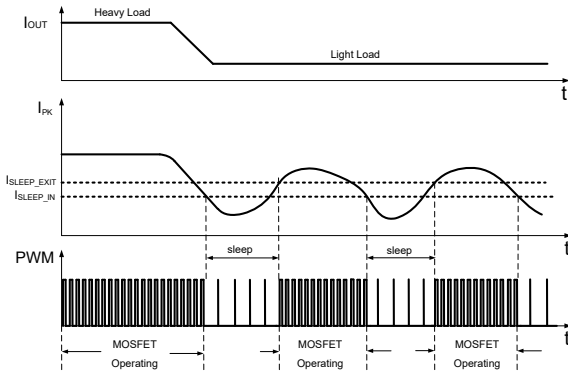

Fig.6 timing diagram of burst mode

Over Current Protection (OCP)

As the circuit operate at start up condition or output short condition, and the output voltage is shorted to zero. When the MOSFET conduct, the inductor current will rise $\Delta I_1 = \frac{(V_{IN}-0) * t_{ON}}{L}$ in a switching period, when the power diode conduct, the inductor current will fall $\Delta I_2 = \frac{(V_{D,F}+0) * t_{OFF}}{L}$ in a switching period. If the current rise value ΔI_1 is larger than current fall value ΔI_2 , the current will rise and the inductor will be saturated, then the circuit will be damaged.

V_{IN} is the input voltage, t_{ON} is MOSFET conducting time, $V_{D,F}$ is the forward voltage drop of power diode, t_{ON} is power diode conducting time. L is inductor value.

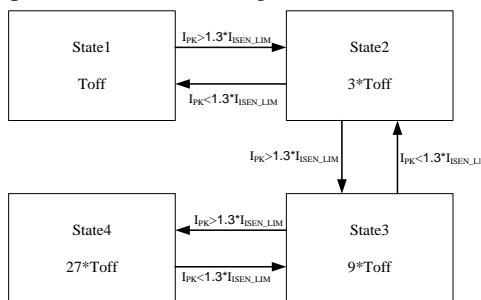

Fig. 7 logic diagram of over current protection

To resolve the problem, the OCP strategy is adopted. When peak current of MOSFET I_{PK} exceeds OCP current threshold (typical 1.3times of I_{ISEN_LIM}), the off time will be changed to 3 times of previous off time. The logic diagram is shown in Fig.7.

At start up condition, when I_{PK} exceeds OCP current threshold, the timing diagram of inductor current is shown in Fig.8.

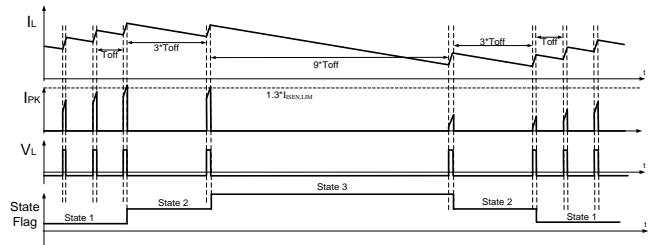

Fig. 8 timing diagram of inductor current

Over Voltage Protection (OVP)

SY22848 will monitor the V_{VCC} , if the V_{VCC} is above V_{VCC_OVP} , IC will shut down the gate pulse till IC restart.

Over Temperature Protection (OTP)

To prevent any thermal damage, SY22848 shuts down switching when its junction temperature exceed T_{SD} . When the junction temperature drops T_{OTP_HYS} , IC will restart.

Power design

Typical application specification:

Products	Input range	Output		Temperature rise
SY22848	90Vac~264Vac	5.4W	18V0.3A	45°C
	90Vac~264Vac	6.48W	18/0.36A	55°C

The test is operated in natural cooling condition at 25 °C ambient temperature.

Inductor Design Considerations

The design rules are as followed:

(a) Compute inductor value L

Consider the thermal performance during all input range, define the ripple coefficient of inductor current as 133%.

$$I_{OUT}=0.36A, \text{ then } \Delta I=1.33*I_{OUT}=0.48A$$

In the range, the IC operation in state1 of MOT in most periods, then the T_{OFF} is 24uS.

$$L=\frac{18V * 24\mu}{0.48A}=900\mu$$

(b) Compute maximum current of inductor

Because of the OCP function, the maximum current of inductor will be limited to 1.3times of I_{ISEN_LIM} . So the saturation current of inductor should be designed as below:

$$I_{MAX}=1.3 * I_{ISEN_LIM}=1.3 * 0.72A=0.963A$$

(c) Preset the maximum magnetic flux ΔB

$$\Delta B=0.3T$$

(d) Compute turns N

$$N=\frac{L * I_{MAX}}{A_e * \Delta B}=\frac{900\mu * 0.963A}{A_e * 0.3}$$

A_e is the cross sectional area of core. Once the A_e is confirmed, the turns of inductor winding can be calculated.

Layout Considerations

(a) To achieve a good EMI performance and to reduce the line frequency voltage ripples, the output of the bridge rectifier should be connected to the BUS line capacitor first, then to the switching circuit.

(b) The circuit loop of all switching circuit should be kept as small as possible, which include: bus cap, SY22848, power diode, inductor and output cap.

(c) The circuit loop of power supply should be kept as small as possible. The bias supply capacitor should be close to the VCC pin.

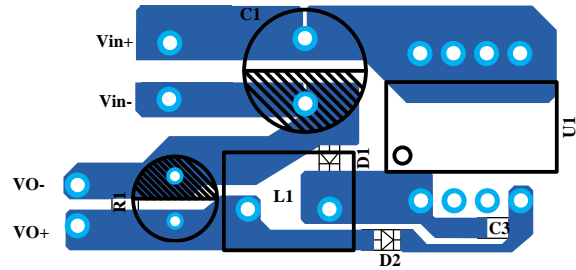

Fig.9 Layout example of Key Part

Figure 10 shows a typical application example of 18V, 360mA non-isolated power supply using.

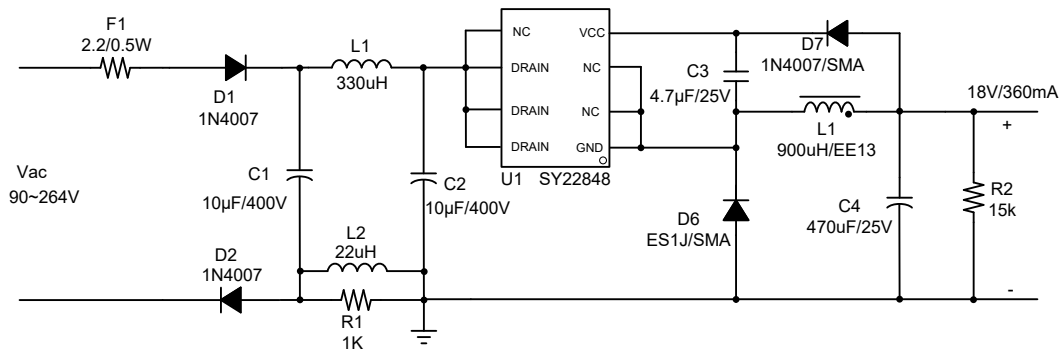
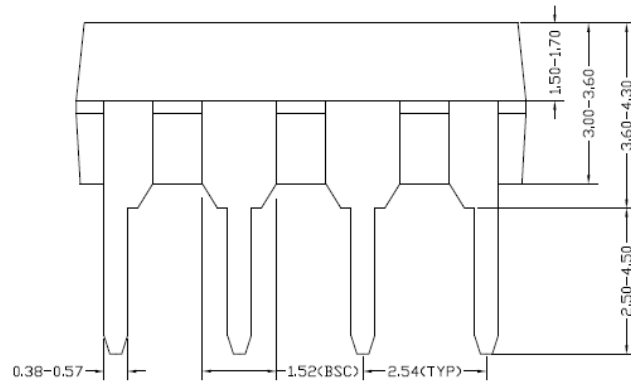

Figure 10 Typical Application at 18V, 360mA

Design Notice

1. The ES1J is recommended to use for power diode.
2. To achieve better startup and sampling performance, the 4.7uF capacitor value is recommended for VCC cap.
3. To optimize the thermal performance, the pin5 of SY22848 could be connected to pin6~8.
4. To simplify the layout, the pin 2/pin 3 could be connected to pin1 or pin4.

DIP8 Package Outline



Side view A

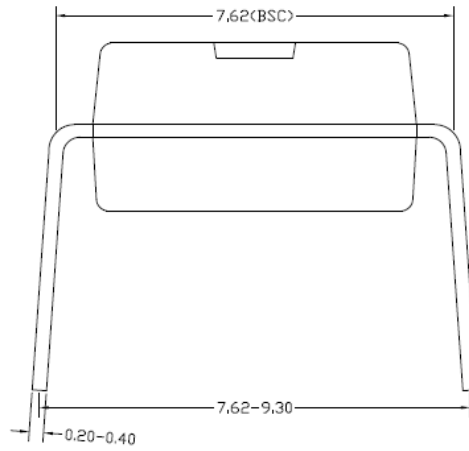

Side view B

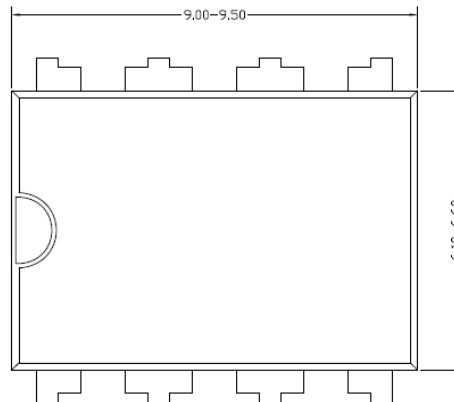

Top view

Notes: All dimension in millimeters and exclude mold flash & metal burr

Revision History

The revision history provided is for informational purpose only and is believed to be accurate, however, not warranted. Please make sure that you have the latest revision.

Date	Revision	Change
December 31,2019	Revision 0.9	Initial Release

IMPORTANT NOTICE

- 1. Right to make changes.** Silergy and its subsidiaries (hereafter Silergy) reserve the right to change any information published in this document, including but not limited to circuitry, specification and/or product design, manufacturing or descriptions, at any time and without notice. This document supersedes and replaces all information supplied prior to the publication hereof. Buyers should obtain the latest relevant information before placing orders and should verify that such information is current and complete. All semiconductor products are sold subject to Silergy’s standard terms and conditions of sale.
- 2. Applications.** Application examples that are described herein for any of these products are for illustrative purposes only. Silergy makes no representation or warranty that such applications will be suitable for the specified use without further testing or modification. Buyers are responsible for the design and operation of their applications and products using Silergy products. Silergy or its subsidiaries assume no liability for any application assistance or designs of customer products. It is customer’s sole responsibility to determine whether the Silergy product is suitable and fit for the customer’s applications and products planned. To minimize the risks associated with customer’s products and applications, customer should provide adequate design and operating safeguards. Customer represents and agrees that it has all the necessary expertise to create and implement safeguards which anticipate dangerous consequences of failures, monitor failures and their consequences, lessen the likelihood of failures that might cause harm and take appropriate remedial actions. Silergy assumes no liability related to any default, damage, costs or problem in the customer’s applications or products, or the application or use by customer’s third-party buyers. Customer will fully indemnify Silergy, its subsidiaries, and their representatives against any damages arising out of the use of any Silergy components in safety-critical applications. It is also buyers’ sole responsibility to warrant and guarantee that any intellectual property rights of a third party are not infringed upon when integrating Silergy products into any application. Silergy assumes no responsibility for any said applications or for any use of any circuitry other than circuitry entirely embodied in a Silergy product.
- 3. Limited warranty and liability.** Information furnished by Silergy in this document is believed to be accurate and reliable. However, Silergy makes no representation or warranty, expressed or implied, as to the accuracy or completeness of such information and shall have no liability for the consequences of use of such information. In no event shall Silergy be liable for any indirect, incidental, punitive, special or consequential damages, including but not limited to lost profits, lost savings, business interruption, costs related to the removal or replacement of any products or rework charges, whether or not such damages are based on tort or negligence, warranty, breach of contract or any other legal theory. Notwithstanding any damages that customer might incur for any reason whatsoever, Silergy’ aggregate and cumulative liability towards customer for the products described herein shall be limited in accordance with the Standard Terms and Conditions of Sale of Silergy.
- 4. Suitability for use.** Customer acknowledges and agrees that it is solely responsible for compliance with all legal, regulatory and safety-related requirements concerning its products, and any use of Silergy components in its applications, notwithstanding any applications-related information or support that may be provided by Silergy. Silergy products are not designed, authorized or warranted to be suitable for use in life support, life-critical or safety-critical systems or equipment, nor in applications where failure or malfunction of an Silergy product can reasonably be expected to result in personal injury, death or severe property or environmental damage. Silergy assumes no liability for inclusion and/or use of Silergy products in such equipment or applications and therefore such inclusion and/or use is at the customer’s own risk.
- 5. Terms and conditions of commercial sale.** Silergy products are sold subject to the standard terms and conditions of commercial sale, as published at <http://www.silergy.com/stdterms>, unless otherwise agreed in a valid written individual agreement specifically agreed to in writing by an authorized officer of Silergy. In case an individual agreement is concluded only the terms and conditions of the respective agreement shall apply. Silergy hereby expressly objects to and denies the application of any customer’s general terms and conditions with regard to the purchase of Silergy products by the customer.
- 6. No offer to sell or license.** Nothing in this document may be interpreted or construed as an offer to sell products that is open for acceptance or the grant, conveyance or implication of any license under any copyrights, patents or other industrial or intellectual property rights. Silergy makes no representation or warranty that any license, either express or implied, is granted under any patent right, copyright, mask work right, or other intellectual property right. Information published by Silergy regarding third-party products or services does not constitute a license to use such products or services or a warranty or endorsement thereof. Use of such information may require a license from a third party under the patents or other intellectual property of the third party, or a license from Silergy under the patents or other intellectual property of Silergy.

For more information, please visit: www.silergy.com

© 2019 Silergy Corp.

All Rights Reserved.