

General Description

The SY205269SLD is a single-line, unidirectional TVS (transient voltage suppressor) designed to provide ESD (electrostatic discharge) protection for various applications. The device safeguards sensitive electronic components from ESD and other transient events. It complies with IEC 61000-4-2 (ESD) ($\pm 30\text{kV}$ air, $\pm 30\text{kV}$ contact discharge) and IEC 61000-4-5 (surge) 100A (8/20 μs) standards.

The SY205269SLD is available in a compact DFN 1.6mm \times 1.0mm-2pin package.

Features

- Operating Voltage: 5V and below
- Capacitance: 600pF(Typical)
- Transient Protection for a Single line
 - IEC 61000-4-2 (ESD) $\pm 30\text{kV}$ (Air) $\pm 30\text{kV}$ (Contact)
 - IEC 61000-4-5 (Surge) 100A (8/20 μs)
- Protects One Control or Power Line
- Low Clamping Voltage

Applications

- VBUS and VBAT Lines
- Desktops, Servers and Laptops
- Smartphones
- Microprocessor-Based equipment
- Portable Instrumentation

Mechanical Characteristics

- DFN1.6 \times 1.0-2 package
- Marking: Device Code, Date Code.
- Packaging: Tape and Reel

Circuit Diagram

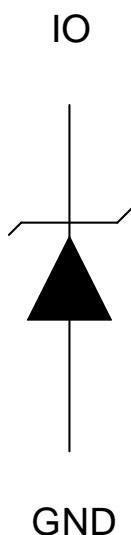

Ordering Information

Part Number	Package Type	Top Mark
SY205269SLD	DFN1.6x1.0-2	BHYWA

Pinout (Top View)

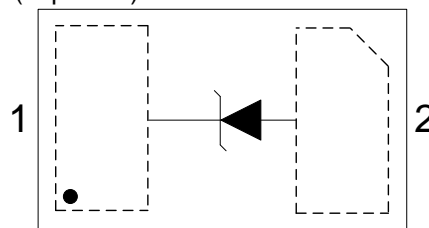

Marking Codes

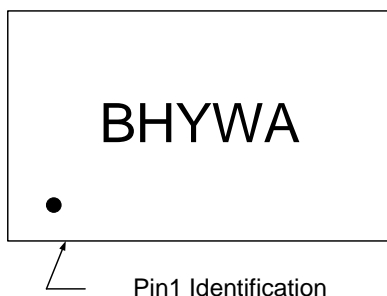

Note 1: “BH” is the device code, fixed.

Note 2: “YWA” is the date code.

Pin Descriptions

Device Pins	Pin Name	Description
1	Input/Output	IO
2	GND	GND

Absolute Maximum Rating

Parameter	Symbol	Min	Max	Unit
ESD per IEC 61000-4-2 (Air)	V_{ESD}	-30	30	kV
ESD per IEC 61000-4-2 (Contact)		-30	30	
Peak Pulse Power ($t_p=8/20\mu s$)	P_{PK}		800	W
Operating Temperature	T_{OPT}	-40	+125	°C
Storage Temperature	T_{STG}	-55	+150	°C

Electrical Characteristics $T_A = 25^\circ C$

Parameter	Symbol	Test Condition	Min	Typ	Max	Unit
Nominal Reverse Working Voltage	V_{RWM}				5.0	V
Reverse Leakage Current at V_{RWM}	I_R	$V_{RWM} = 5V, T_A = 25^\circ C$			3	μA
Reverse Breakdown Voltage at I_R	V_{BR}	$I_T = 1mA, \text{Pin1 to Pin2}$	5.5		8	V
Forward voltage	V_F	$I_F = 1mA, \text{Pin2 to Pin1}$	0.4		1.2	V
Clamping Voltage at I_{PP}	V_C^1	$I_{PP} = 16A, t_p = 10/100ns$		5.5		V
Clamping Voltage at I_{PP}	V_C^1	$I_{PP} = 100A, t_p = 8/20us$		8		V
Dynamic Resistance	$R_{DYN}^{1,2}$	$t_p = 10/100ns$		0.01		Ω
Parasitic Capacitance	C_{ESD}^1	$V_R = 0V, f = 1MHz$		600		pF

Note 1: Guaranteed by design and not subject to production test.

Note 2: R_{DYN} calculated based on $I_{PP}=8A$ to $I_{PP}=16A, t_p = 10/100ns$.

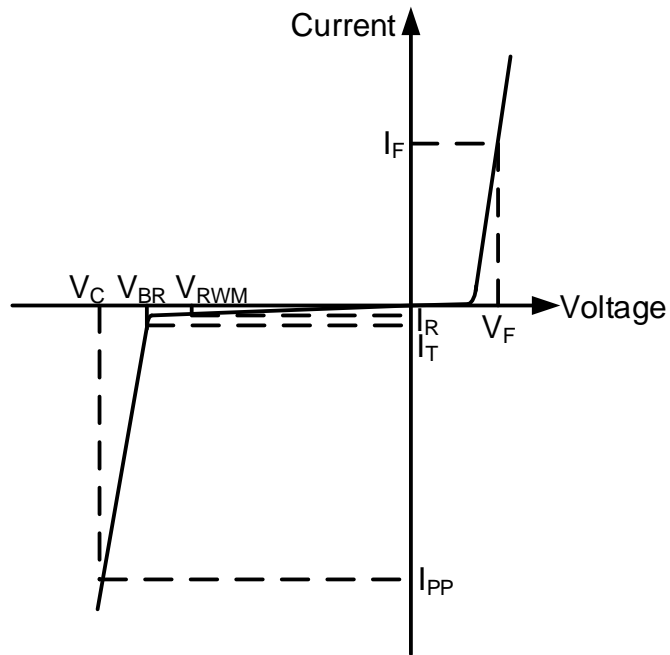
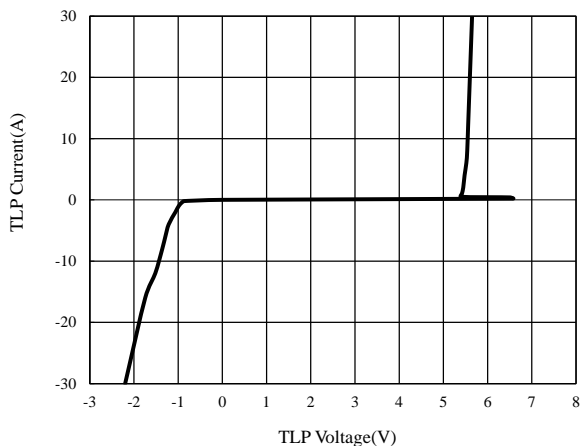

Figure 1. Uni-directional TVS

Typical Characteristics

TLP Testing of IO to GND



Clamping Voltage vs. Peak Pulse Current (8/20μs)

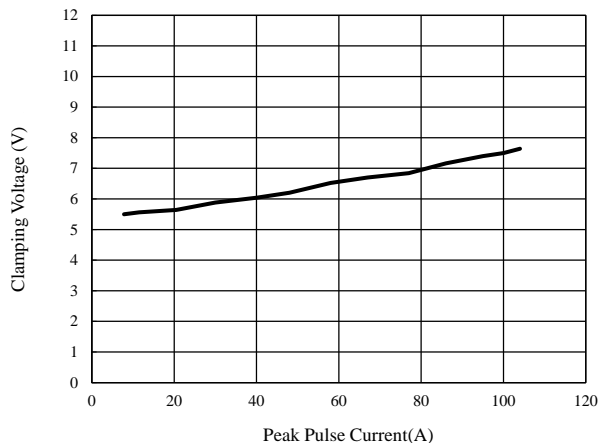

Capacitance vs. Reverse Voltage

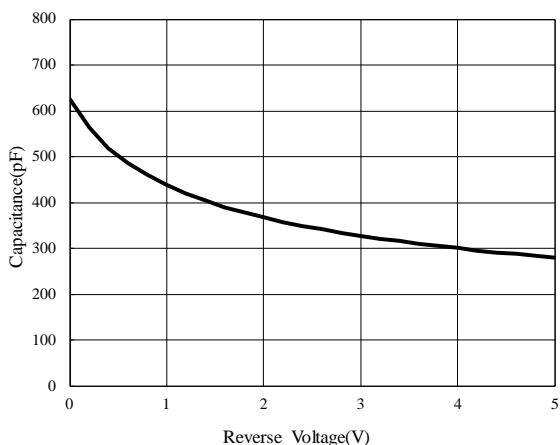

8/20μs Pulse Waveform

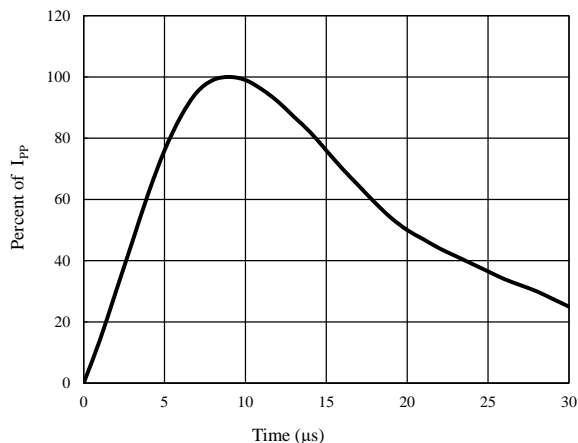

ESD Clamping of IO to GND (+8kV Contact per IEC 61000-4-2)

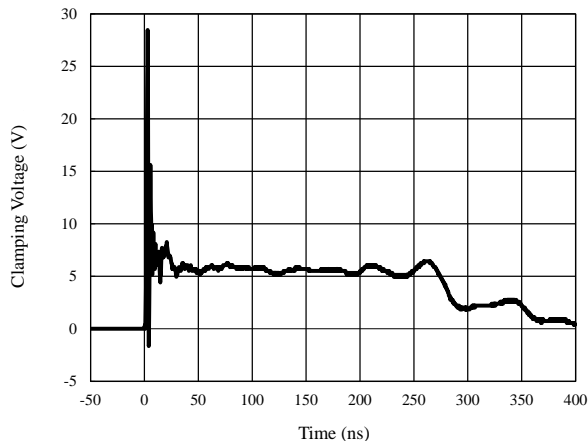

ESD Clamping of IO to GND (-8kV Contact per IEC 61000-4-2)

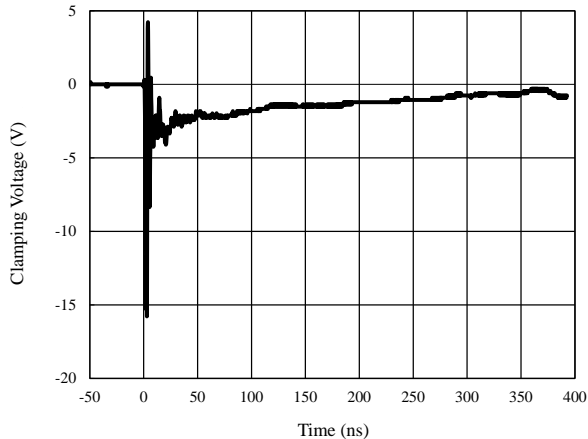

Application Information

Pin Connection in PCB

The SY205269SLD can protect one uni-directional line. It can be used to protect a single power or VBAT line. The pin connections are shown in Figure 2.

The single power or VBAT line can be connected directly to Pin1. Pin2 of the SY205269SLD is the negative reference pin, which should connect to the GND. The connection traces should be as short as possible to minimize parasitic inductance.

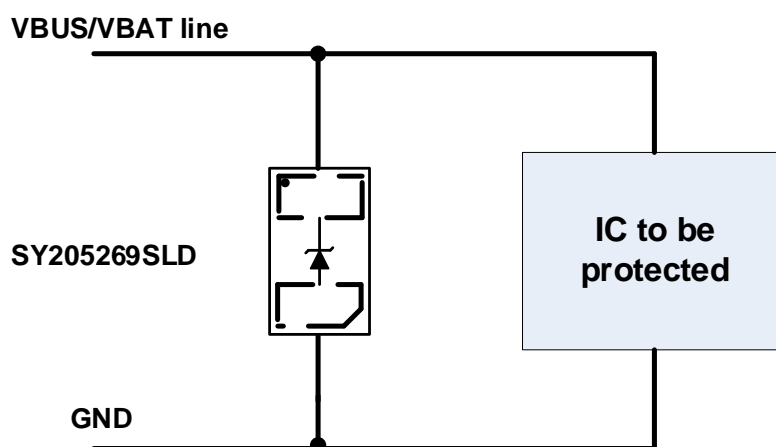

Figure 2. SY205269SLD Pin Connection in PCB

PCB Layout Guidelines

For optimum ESD protection and circuit performance, the following PCB layout guidelines are recommended:

- The distance between Pin2 and the PCB GND should be as short as possible to reduce the ESD transient return path to GND.
- Use large vias to connect Pin1 and Pin2 to the PCB VCC and GND.
- Place the SY205269SLD as close to the connector or battery port as possible to reduce parasitic inductance and reduce ESD coupling into adjacent traces

DFN1.6x1.0-2 Package Outline

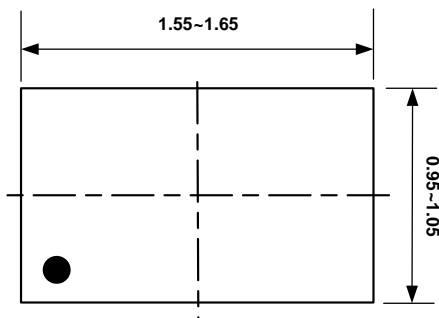

Top View

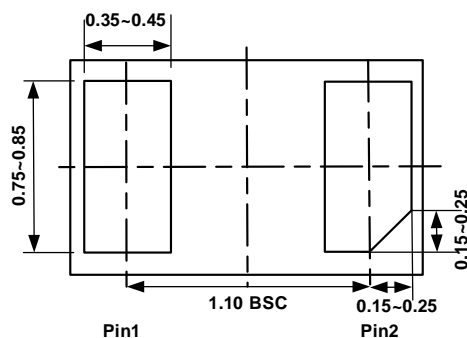

Bottom View

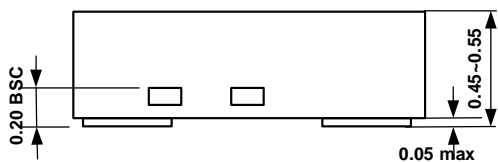

Side View

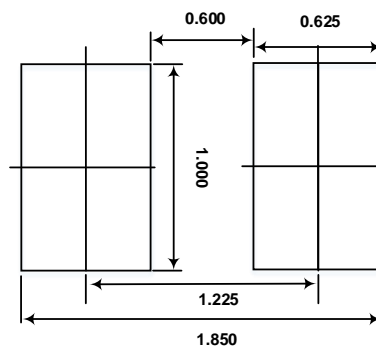

Recommended PCB Layout

Note: All dimensions are in millimeters and exclude mold flash and metal burr..

Taping & Reel Specification

DFN1.6x1.0-2 Taping Orientation

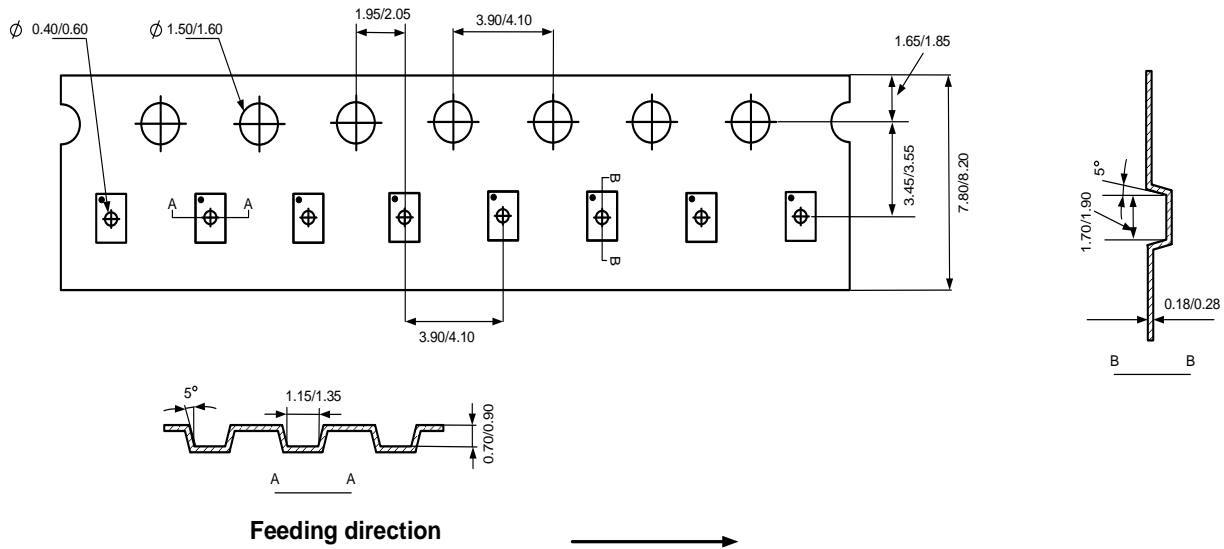

Carrier Tape & Reel Specification for Packages

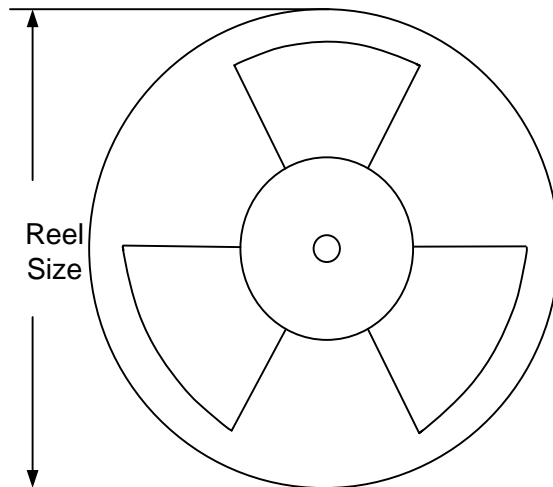

Package Types	Tape Width (mm)	Pocket Pitch(mm)	Reel Size (Inch)	Qty per Reel(pcs)
DFN1.6x1.0-2	8	4	7"	3000



Revision History

The revision history provided is for informational purpose only and is believed to be accurate, however, not warranted. Please make sure that you have the latest revision.

Revision Number	Revision Date	Description	Pages changed
1.0	Mar 27, 2024	Initial Release	

IMPORTANT NOTICE

- 1. Right to make changes.** Silergy and its subsidiaries (hereafter Silergy) reserve the right to change any information published in this document, including but not limited to circuitry, specification and/or product design, manufacturing or descriptions, at any time and without notice. This document supersedes and replaces all information supplied prior to the publication hereof. Buyers should obtain the latest relevant information before placing orders and should verify that such information is current and complete. All semiconductor products are sold subject to Silergy's standard terms and conditions of sale.
- 2. Applications.** Application examples that are described herein for any of these products are for illustrative purposes only. Silergy makes no representation or warranty that such applications will be suitable for the specified use without further testing or modification. Buyers are responsible for the design and operation of their applications and products using Silergy products. Silergy or its subsidiaries assume no liability for any application assistance or designs of customer products. It is customer's sole responsibility to determine whether the Silergy product is suitable and fit for the customer's applications and products planned. To minimize the risks associated with customer's products and applications, customer should provide adequate design and operating safeguards. Customer represents and agrees that it has all the necessary expertise to create and implement safeguards which anticipate dangerous consequences of failures, monitor failures and their consequences, lessen the likelihood of failures that might cause harm and take appropriate remedial actions. Silergy assumes no liability related to any default, damage, costs or problem in the customer's applications or products, or the application or use by customer's third-party buyers. Customer will fully indemnify Silergy, its subsidiaries, and their representatives against any damages arising out of the use of any Silergy components in safety-critical applications. It is also buyers' sole responsibility to warrant and guarantee that any intellectual property rights of a third party are not infringed upon when integrating Silergy products into any application. Silergy assumes no responsibility for any said applications or for any use of any circuitry other than circuitry entirely embodied in a Silergy product.
- 3. Limited warranty and liability.** Information furnished by Silergy in this document is believed to be accurate and reliable. However, Silergy makes no representation or warranty, expressed or implied, as to the accuracy or completeness of such information and shall have no liability for the consequences of use of such information. In no event shall Silergy be liable for any indirect, incidental, punitive, special or consequential damages, including but not limited to lost profits, lost savings, business interruption, costs related to the removal or replacement of any products or rework charges, whether or not such damages are based on tort or negligence, warranty, breach of contract or any other legal theory. Notwithstanding any damages that customer might incur for any reason whatsoever, Silergy' aggregate and cumulative liability towards customer for the products described herein shall be limited in accordance with the Standard Terms and Conditions of Sale of Silergy.
- 4. Suitability for use.** Customer acknowledges and agrees that it is solely responsible for compliance with all legal, regulatory and safety-related requirements concerning its products, and any use of Silergy components in its applications, notwithstanding any applications-related information or support that may be provided by Silergy. Silergy products are not designed, authorized or warranted to be suitable for use in life support, life-critical or safety-critical systems or equipment, nor in applications where failure or malfunction of a Silergy product can reasonably be expected to result in personal injury, death or severe property or environmental damage. Silergy assumes no liability for inclusion and/or use of Silergy products in such equipment or applications and therefore such inclusion and/or use is at the customer's own risk.
- 5. Terms and conditions of commercial sale.** Silergy products are sold subject to the standard terms and conditions of commercial sale, as published at <http://www.silergy.com>, unless otherwise agreed in a valid written individual agreement specifically agreed to in writing by an authorized officer of Silergy. In case an individual agreement is concluded only the terms and conditions of the respective agreement shall apply. Silergy hereby expressly objects to and denies the application of any customer's general terms and conditions with regard to the purchase of Silergy products by the customer.
- 6. No offer to sell or license.** Nothing in this document may be interpreted or construed as an offer to sell products that is open for acceptance or the grant, conveyance or implication of any license under any copyrights, patents or other industrial or intellectual property rights. Silergy makes no representation or warranty that any license, either express or implied, is granted under any patent right, copyright, mask work right, or other intellectual property right. Information published by Silergy regarding third-party products or services does not constitute a license to use such products or services or a warranty or endorsement thereof. Use of such information may require a license from a third party under the patents or other intellectual property of the third party, or a license from Silergy under the patents or other intellectual property of Silergy.

For more information, please visit: www.silergy.com

© 2024 Silergy Corp.

All Rights Reserved.