

General Description

The SY205272DVD is an ultra-low capacitance transient voltage suppressor (TVS) designed to provide electrostatic discharge (ESD) protection for high speed data interfaces.

With a typical capacitance of 0.18pF, the SY205272DVD is designed to protect parasitic-sensitive systems against overvoltage and overcurrent transient events. It complies with IEC 61000-4-2 (ESD), ($\pm 15\text{kV}$ air, $\pm 9\text{kV}$ contact discharge), and IEC 61000-4-5 (surge) (4.5A, 8/20 μs) standards.

Each SY205272DVD device can protect four high-speed data lines. The combined features of ultra-low capacitance, ultra-small size, and high ESD robustness make the SY205272DVD ideal for high-speed data ports and high-frequency lines (e.g., USB 3.x and DVI) applications. The low clamping voltage of the SY205272DVD ensures minimal stress on the protected device.

The SY205272DVD is available in a compact DFN2.5x1.0-10 package.

Features

- Operating Voltage: 3.3V and Below
- Transient Protection for Four High Speed Data Lines
 - IEC61000-4-2 (ESD) $\pm 15\text{kV}$ (Air) $\pm 9\text{kV}$ (Contact)
 - IEC61000-4-5 (Surge) 4.5A (8/20 μs)
- Ultra Low Capacitance: 0.18pF (Typ.)
- Low Clamping Voltage

Applications

- USB 2.0 and 3.x
- USB Type-C
- HDMI2.0, HDMI2.1
- V-By-One
- DP1.4, DP2.1

Mechanical Characteristics

- DFN2.5x1.0-10 Package
- Marking: Device Code, Date Code
- Packaging: Tape and Reel

Circuit Diagram

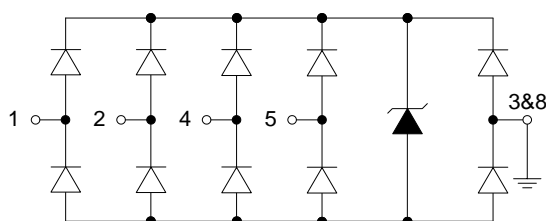

Ordering Information

Pinout (Top View)

Part Number	Package Type	Top Mark
SY205272DVD	DFN2.5x1.0-10	8eYWA

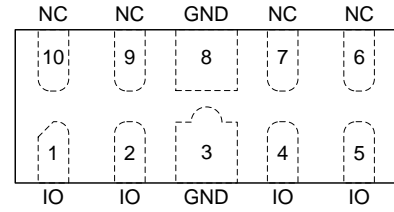

Marking Codes

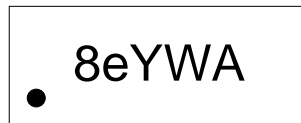

Note 1: "8e" is the device code, fixed.

Note 2: "YWA" is the date code.

Pin Descriptions

Device Pins	Name	Description
1	Input/Output	IO1
2	Input/Output	IO2
3	Ground	GND
4	Input/Output	IO3
5	Input/Output	IO4

Absolute Maximum Rating				
Parameter	Symbol	Min	Max	Unit
Maximum Peak Pulse Current (8/20 μ s)	I_{PP}		4.5	A
ESD per IEC 61000-4-2 (Air)	V_{ESD}	-15	15	kV
ESD per IEC 61000-4-2 (Contact)		-9	9	
Junction Temperature	T_J	-40	+125	$^{\circ}$ C
Storage Temperature	T_{STG}	-55	+150	$^{\circ}$ C

Electrical Characteristics $T_A = 25^{\circ}$ C						
Parameter	Symbol	Test Condition	Min	Typ	Max	Unit
Nominal Reverse Working Voltage	V_{RWM}		-3.3		3.3	V
Reverse Leakage Current at V_{RWM}	I_R	$V_{RWM} = 3.3V, T_A = 25^{\circ}$ C		0.01	0.1	μ A
Reverse Triggering Voltage at I_{t1}	V_{t1}	$I_{t1} = 0.1mA$	5.6		10	V
Clamping Voltage at I_{PP}	V_C^1	$I_{PP} = 16A, t_p = 10/100ns$		11		V
Clamping Voltage at I_{PP}	V_C^1	$I_{PP} = 4.5A, t_p = 8/20\mu s$		6	7	V
Dynamic Resistance	$R_{DYN}^{1,2}$	$t_p = 10/100ns$		0.23		Ω
Parasitic Capacitance	C_{ESD}^1	$V_R = 1.65V, f = 1MHz$		0.18	0.22	pF

Note 1: Guaranteed by design and not subject to production test.

Note 2: R_{DYN} calculated based on $I_{PP}=8A$ to $I_{PP}=16A$, $t_p = 10/100ns$.

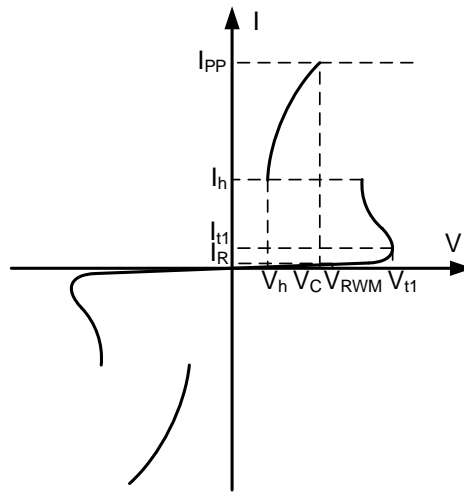
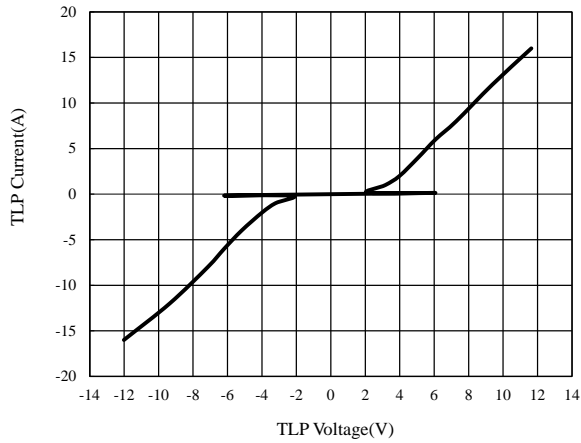

Figure 1. Bi-Directional TVS

Typical Performance Characteristics

TLP Testing of IO to GND



Clamping Voltage vs. Peak Pulse Current (8/20μs)

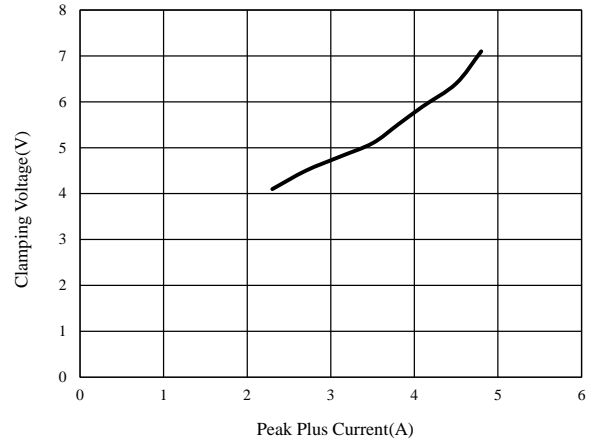

Capacitance vs. Voltage of IO to GND

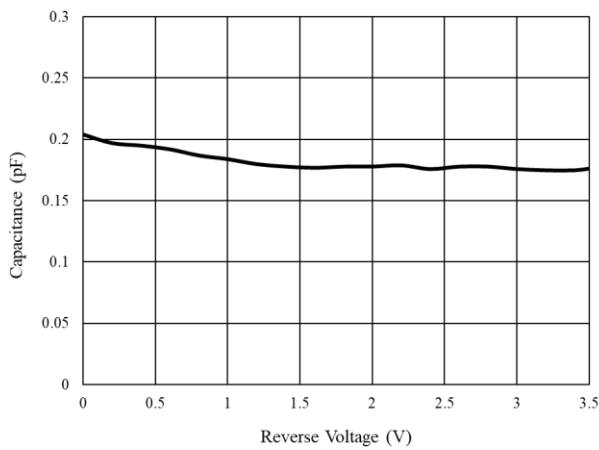

Insertion Loss S21 of IO to GND

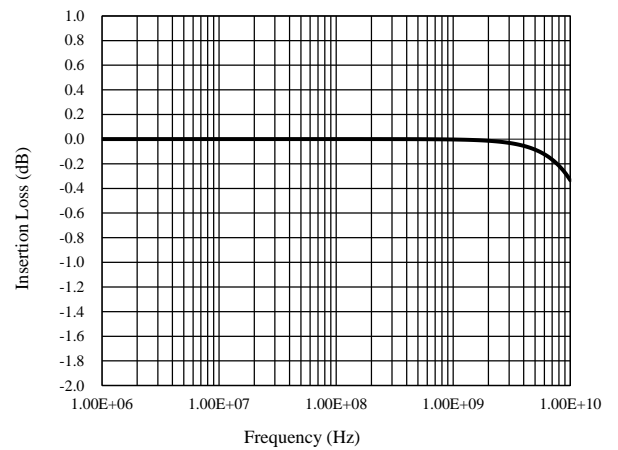

ESD Clamping of IO to GND (+8kV Contact per IEC 61000-4-2)

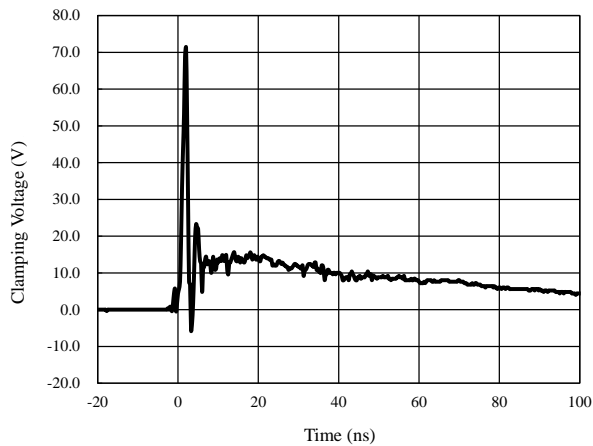

ESD Clamping of IO to GND (-8kV Contact per IEC 61000-4-2)

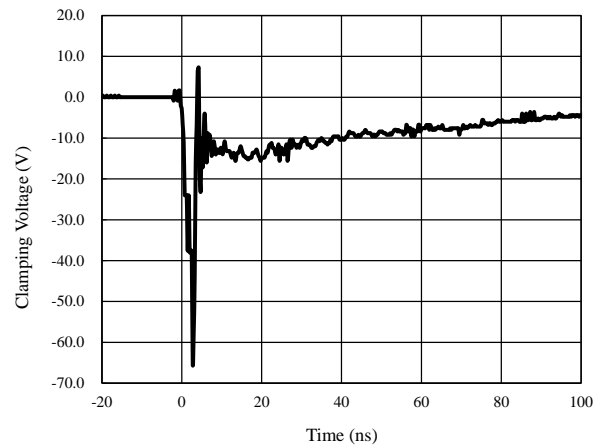

Eye Diagram Measurement for HDMI2.1

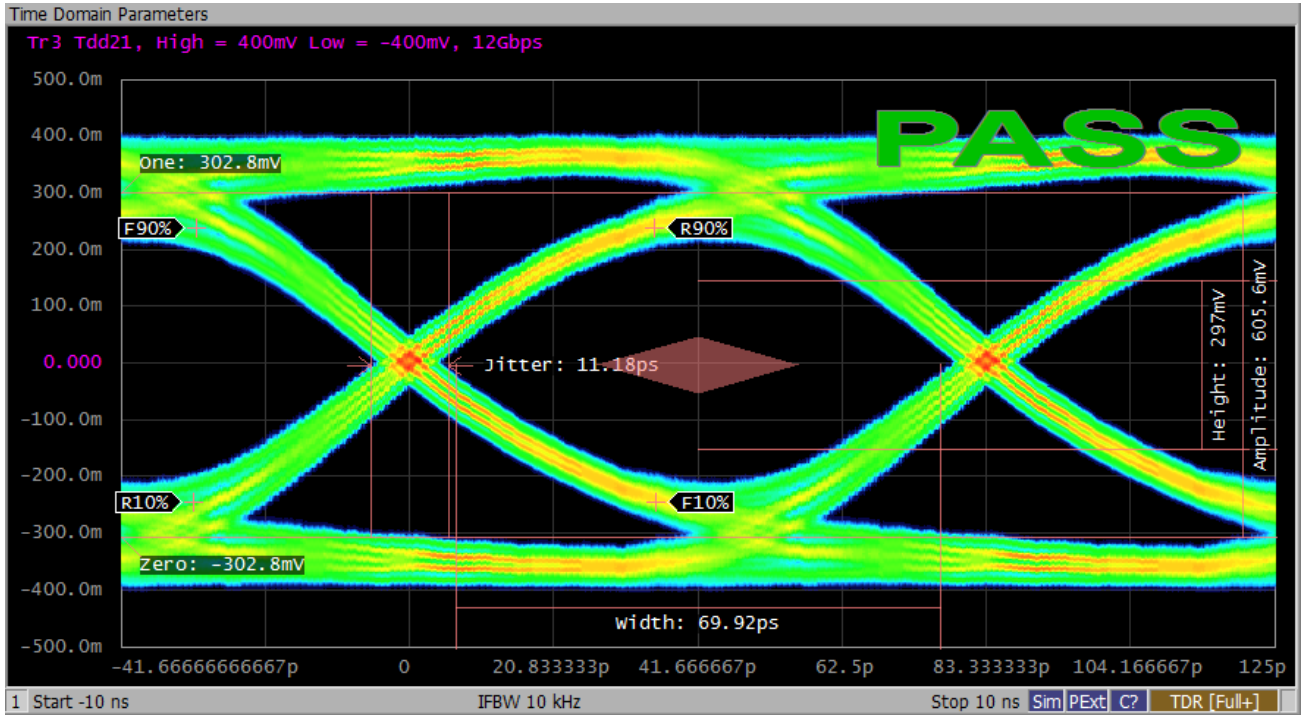

Figure 2. HDMI2.1 Eye Diagram without SY205272DVD
Data Rate 12Gb/s

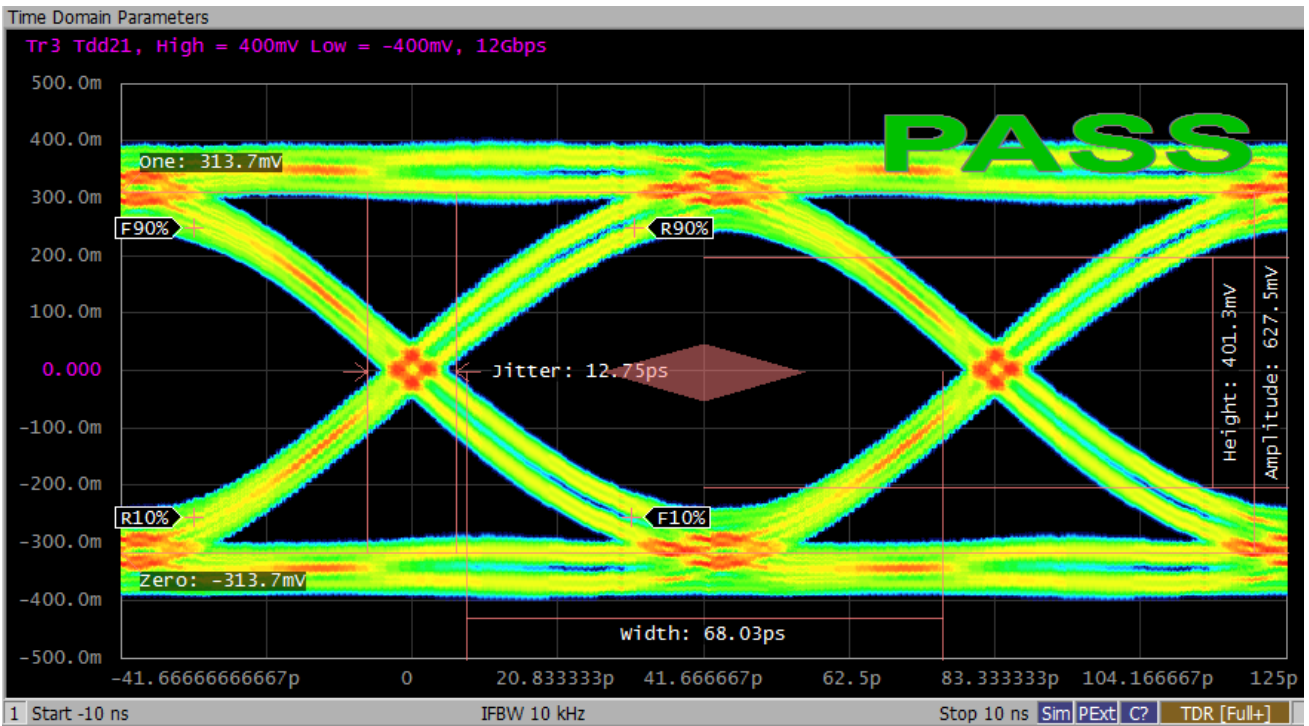

Figure 3. HDMI2.1 Eye Diagram with SY205272DVD
Data Rate 12Gb/s

Application Information

Pin Connections in PCB

The SY205272DVD provides ESD protection for four data lines simultaneously. The pin connections are shown in Figure 4 below.

Four parallel data lines, from the internal device to the IO port connector, can be connected directly to the four IO pins of the SY205272DVD. Pin 3 and Pin 8 of the SY205272DVD are GND pins and should be connected to the PCB ground. The connection wires should be as short as possible to minimize parasitic inductance.

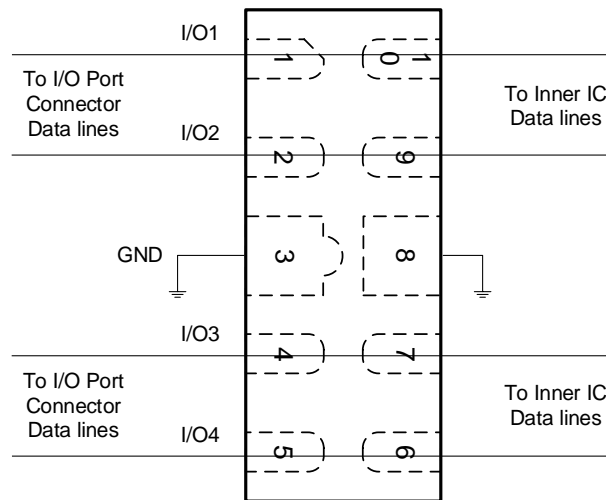

Figure 4. SY205272DVD Pin Connections in PCB

PCB Layout Guidelines

For optimum ESD protection and circuit performance, the following PCB layout guidelines are recommended:

1. The path from the SY205272DVD GND pin to the PCB GND rail should be as short as possible to reduce the ESD transient return path to GND.
2. Use large vias to connect the SY205272DVD GND pins to the PCB GND.
3. Place the SY205272DVD as close to the connector port as possible to reduce parasitic inductance and restrict ESD coupling into adjacent traces.
4. Avoid running critical signals near board edges.

DFN2.5x1.0-10 Package Outline

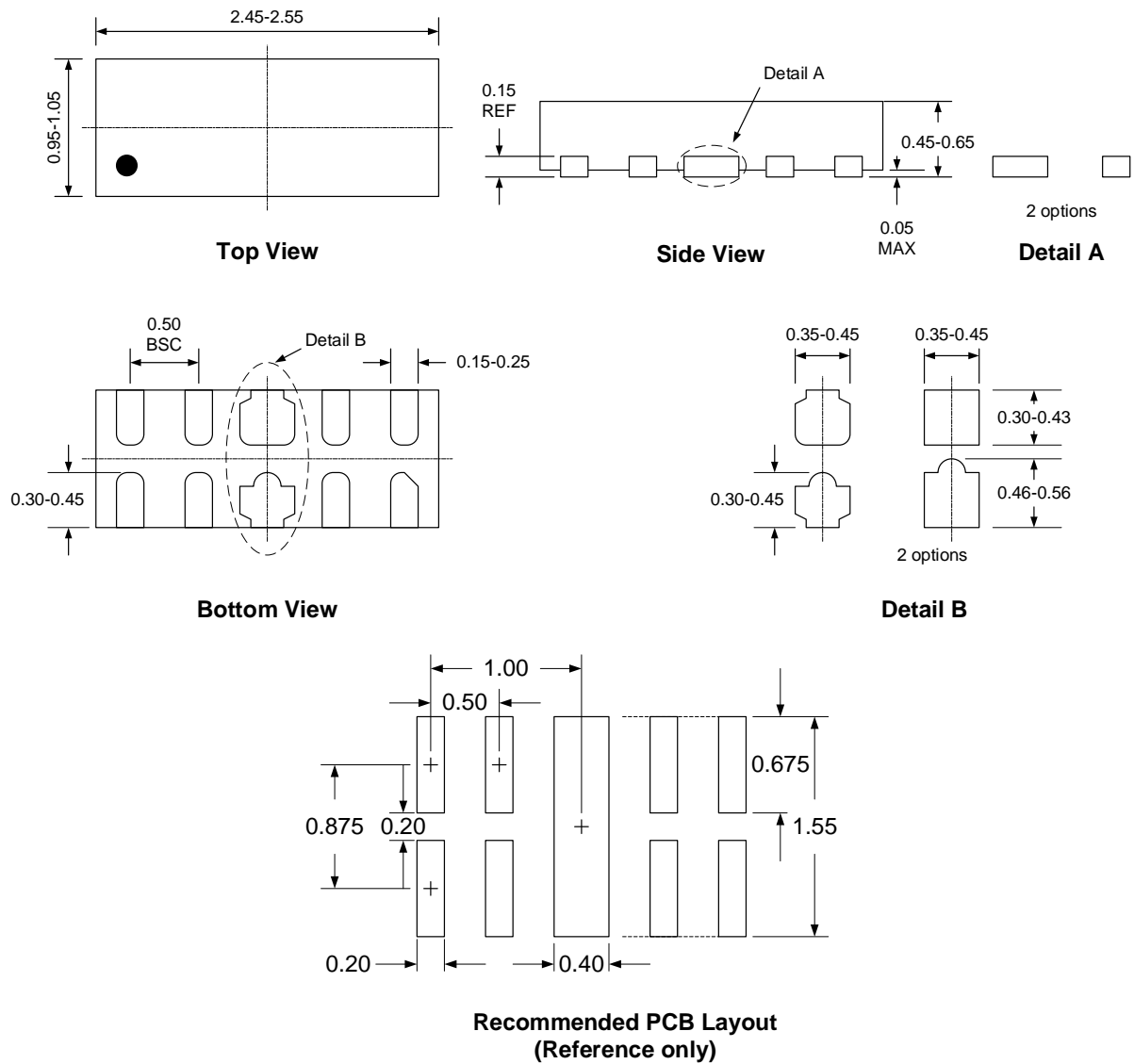

Note: All dimensions are in millimeters and exclude mold flash and metal burr.

Tape and Reel Information

Taping Dimensions and Pin 1 Orientation

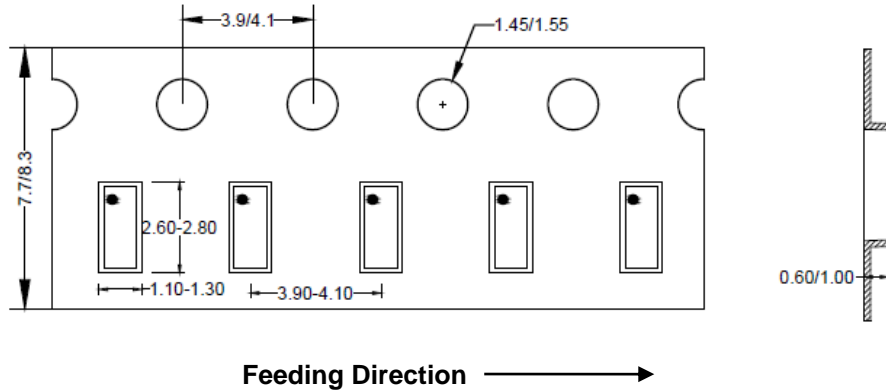

Reel Dimensions

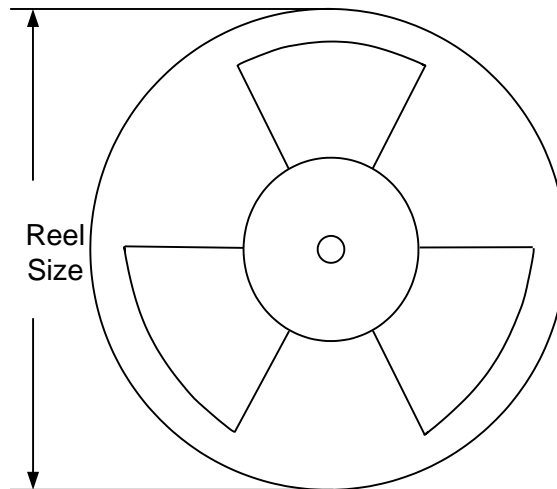

Package Type	Tape Width (mm)	Pocket Pitch (mm)	Reel Size (Inch)	Qty per Reel (pcs)
DFN2.5x1.0-10	8	4	7"	3000



Revision History

The revision history provided is for informational purposes only and is believed to be accurate; however, not warranted. Please make sure that you have the latest revision.

Revision Number	Revision Date	Description	Pages changed
1.0	May 27, 2024	Initial Release	

IMPORTANT NOTICE

- 1. Right to make changes.** Silergy and its subsidiaries (hereafter Silergy) reserve the right to change any information published in this document, including but not limited to circuitry, specification and/or product design, manufacturing or descriptions, at any time and without notice. This document supersedes and replaces all information supplied prior to the publication hereof. Buyers should obtain the latest relevant information before placing orders and should verify that such information is current and complete. All semiconductor products are sold subject to Silergy's standard terms and conditions of sale.
- 2. Applications.** Application examples that are described herein for any of these products are for illustrative purposes only. Silergy makes no representation or warranty that such applications will be suitable for the specified use without further testing or modification. Buyers are responsible for the design and operation of their applications and products using Silergy products. Silergy or its subsidiaries assume no liability for any application assistance or designs of customer products. It is customer's sole responsibility to determine whether the Silergy product is suitable and fit for the customer's applications and products planned. To minimize the risks associated with customer's products and applications, customer should provide adequate design and operating safeguards. Customer represents and agrees that it has all the necessary expertise to create and implement safeguards which anticipate dangerous consequences of failures, monitor failures and their consequences, lessen the likelihood of failures that might cause harm and take appropriate remedial actions. Silergy assumes no liability related to any default, damage, costs or problem in the customer's applications or products, or the application or use by customer's third-party buyers. Customer will fully indemnify Silergy, its subsidiaries, and their representatives against any damages arising out of the use of any Silergy components in safety-critical applications. It is also buyers' sole responsibility to warrant and guarantee that any intellectual property rights of a third party are not infringed upon when integrating Silergy products into any application. Silergy assumes no responsibility for any said applications or for any use of any circuitry other than circuitry entirely embodied in a Silergy product.
- 3. Limited warranty and liability.** Information furnished by Silergy in this document is believed to be accurate and reliable. However, Silergy makes no representation or warranty, expressed or implied, as to the accuracy or completeness of such information and shall have no liability for the consequences of use of such information. In no event shall Silergy be liable for any indirect, incidental, punitive, special or consequential damages, including but not limited to lost profits, lost savings, business interruption, costs related to the removal or replacement of any products or rework charges, whether or not such damages are based on tort or negligence, warranty, breach of contract or any other legal theory. Notwithstanding any damages that customer might incur for any reason whatsoever, Silergy' aggregate and cumulative liability towards customer for the products described herein shall be limited in accordance with the Standard Terms and Conditions of Sale of Silergy.
- 4. Suitability for use.** Customer acknowledges and agrees that it is solely responsible for compliance with all legal, regulatory and safety-related requirements concerning its products, and any use of Silergy components in its applications, notwithstanding any applications-related information or support that may be provided by Silergy. Silergy products are not designed, authorized or warranted to be suitable for use in life support, life-critical or safety-critical systems or equipment, nor in applications where failure or malfunction of a Silergy product can reasonably be expected to result in personal injury, death or severe property or environmental damage. Silergy assumes no liability for inclusion and/or use of Silergy products in such equipment or applications and therefore such inclusion and/or use is at the customer's own risk.
- 5. Terms and conditions of commercial sale.** Silergy products are sold subject to the standard terms and conditions of commercial sale, as published at <http://www.silergy.com>, unless otherwise agreed in a valid written individual agreement specifically agreed to in writing by an authorized officer of Silergy. In case an individual agreement is concluded only the terms and conditions of the respective agreement shall apply. Silergy hereby expressly objects to and denies the application of any customer's general terms and conditions with regard to the purchase of Silergy products by the customer.
- 6. No offer to sell or license.** Nothing in this document may be interpreted or construed as an offer to sell products that is open for acceptance or the grant, conveyance or implication of any license under any copyrights, patents or other industrial or intellectual property rights. Silergy makes no representation or warranty that any license, either express or implied, is granted under any patent right, copyright, mask work right, or other intellectual property right. Information published by Silergy regarding third-party products or services does not constitute a license to use such products or services or a warranty or endorsement thereof. Use of such information may require a license from a third party under the patents or other intellectual property of the third party, or a license from Silergy under the patents or other intellectual property of Silergy.

For more information, please visit: www.silergy.com

© 2024 Silergy Corp.

All Rights Reserved.