

### General Description

The SQ33020 is a high frequency quasi-resonant (QR) flyback controller designed for power delivery (PD) adaptors and quick battery chargers. It can deliver 240W output power with 25kHz–500kHz switching frequency.

The SQ33020 operates using peak current control. It provides a QR mode in which the MOSFET can be turned on at a valley point to reduce switching loss, especially under high input voltages.

In conventional QR flyback solutions, the valley number always varies between 1 and 2 or between 3 and 5, which increases  $V_o$  ripple and creates audible noise. The SQ33020 uses a proprietary circuit to lock the valley number between 1 and 6, which provides more stability than conventional QR solutions.

If load decreases, the SQ33020 will enter discontinuous conduction mode (DCM) to reduce the switching frequency for higher efficiency. Under very light loads, the SQ33020 enters burst mode to reduce power loss.

The SQ33020 provides multiple mechanisms to ensure reliable operation: HV startup, X capacitor discharge, brown-out protection, output and VCC overvoltage protection (OVP), output undervoltage protection (UVP), internal and external overtemperature protection (OTP), and open-loop protection (OLP).

For higher efficiency, use the SQ33239 as a secondary side synchronous rectifier controller in conjunction with the SQ33020 to achieve zero voltage switching (ZVS).

The SQ33020 is available in an SSOP9 package.

### Features

- DCM+QR Combined Operating Mode
- Programmable Gate Driver Current
- Switching Frequency Range: 25kHz–500kHz
- Automatic Valley Lockout from 1 to 6 cycles
- Accurate Output OCP
- Adaptive OCP (Limited Power Source)
- Low Frequency Burst Operation (1kHz)
- Switching Frequency Modulation to Reduce EMI Noise
- Internal Soft-Start
- Integrated 700V HV Startup
- Brown-In/Brown-Out Protections
- X Capacitor Discharge Protection (Optional)
- Programmable Output OVP and UVP
- Current Sense Resistor Short Protection
- Internal and External OTP
- Compact Package: SSOP9

### Applications

- AC/DC Adapters
- PD Adapters
- Quick Battery Chargers

### Typical Application

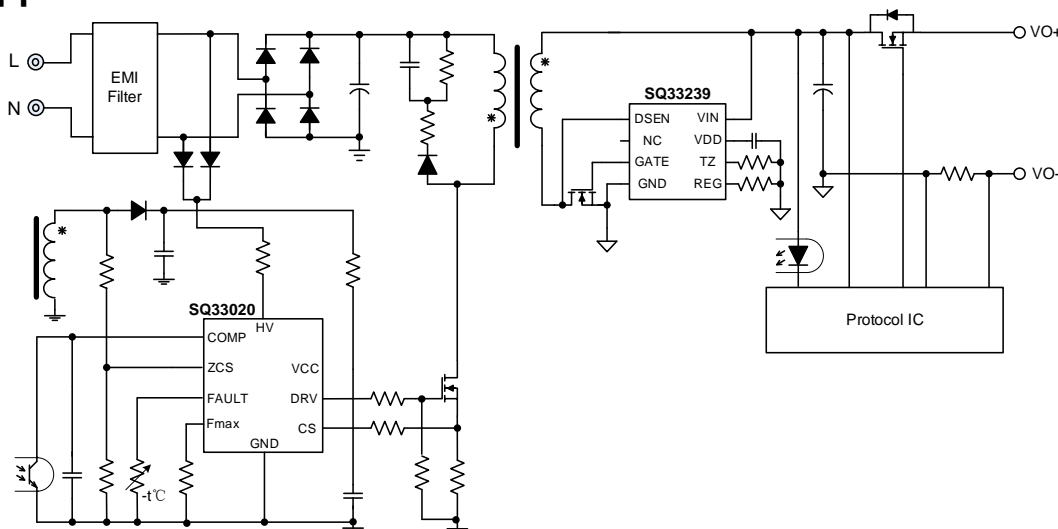

Figure 1. Typical Application Circuit using Synchronous Rectification (SR)

## Ordering Information

Ordering Part Number	Package type	Top Mark
SQ33020FVP	SSOP9 RoHS-Compliant and Halogen-Free	<b>FDExyz</b>

*x = year code, y = week code, z = lot number code*

## Pinout (top view)

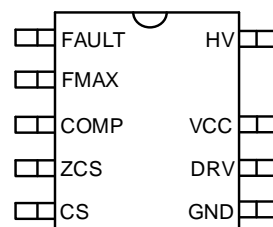

## Pin Description

Pin No	Pin Name	Pin Description
1	FAULT	External OTP and V <sub>OUT</sub> OVP pin
2	FMAX	Maximum frequency (f <sub>MAX</sub> ) set pin with an external resistor to GND
3	COMP	Compensation voltage of secondary side, connected to an optocoupler
4	ZCS	Output voltage, input voltage, and QR valley detection pin
5	CS	Transformer current sensing pin
6	GND	Ground pin
7	DRV	Programmable MOSFET gate drive pin
8	VCC	Power supply pin
9	HV	HV startup, brown-in/out, X capacitor discharge detection pin

Block Diagram

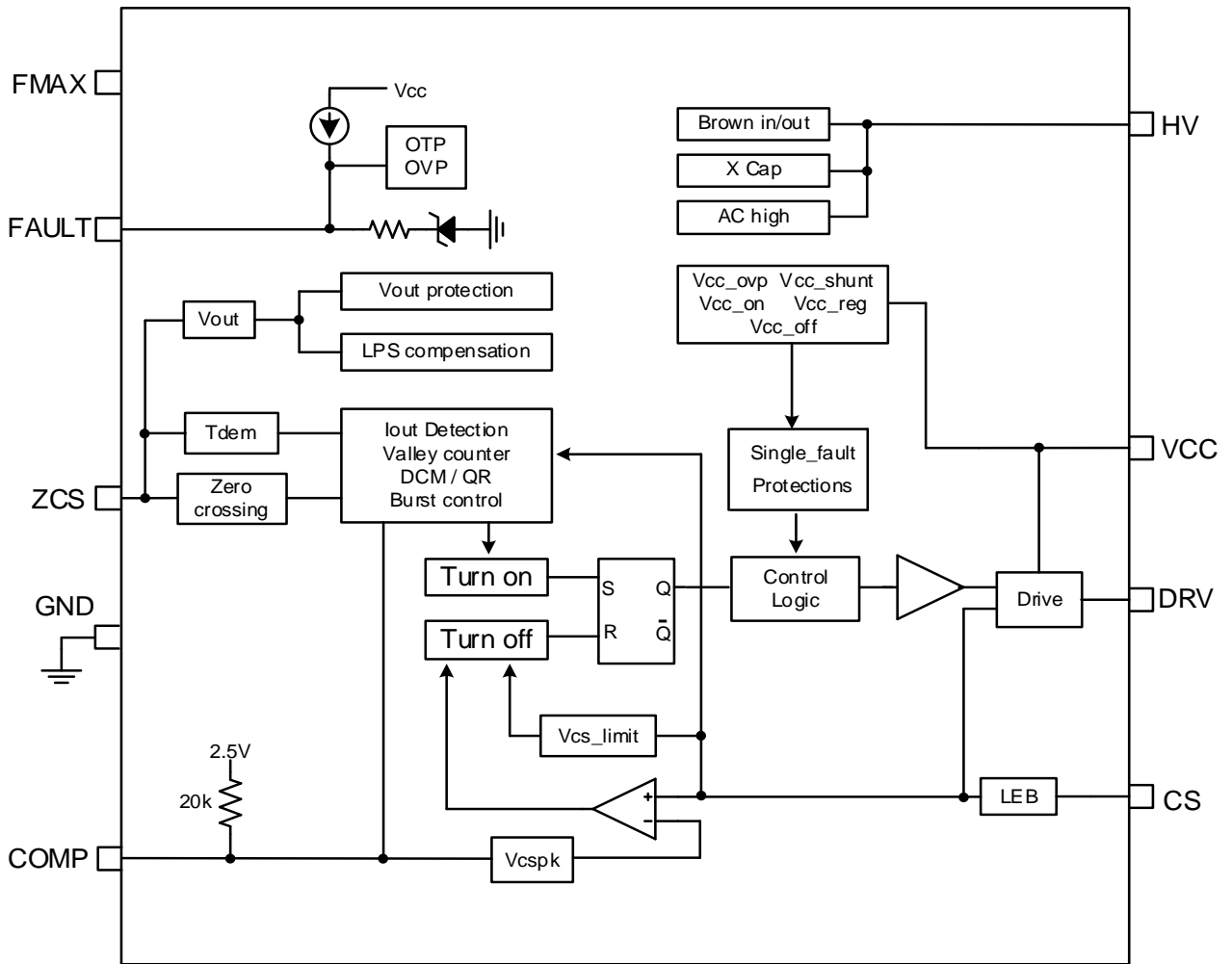

Figure 2. Block Diagram

## Absolute Maximum Ratings

Parameter (Note 1)	Min	Max	Unit
HV	-0.3	700	V
VCC	-0.3	30	
DRV	-0.3	16	
CS, COMP, FAULT, FMAX	-0.3	4	
ZCS	-1 (Note 1)	7	
Junction Temperature, Operating	-40	150	°C
Lead Temperature (Soldering, 10s)		260	
Storage Temperature Range	-60	150	
Note1, Dynamic ZCS Negative Voltage in 50µs Duration		-1	V
Note1, Dynamic ZCS Negative Current in 50µs Duration		-2	mA
Human Body Model ESD (HV Pin and VCCH Pin) per ESDA/JEDEC JS-001-2017 (Note 6)		±1	kV
Human Body Model ESD (All Pins Except HV Pin and VCCH Pin) per ESDA/JEDEC JS-001-2017 (Note 6)		±2	kV
Charged Device Model ESD per JS-002-2018 (Note 6)		±500	V
Latch-Up Test per JEDEC78E (Note 6)		±100	mA
MSL Rating		3	

## Thermal Information

Parameter (Note 2)	Min	Max	Unit
$\theta_{JA}$ Junction-to-Ambient Thermal Resistance		158	°C/W
$\theta_{JC}$ Junction-to-Case Thermal Resistance		30	
PD Power Dissipation $T_A = 25^\circ\text{C}$		0.79	W

## Recommended Operating Conditions

Parameter	Min	Max	Unit
HV	-0.3	700	V
VCC	9	25	
DRV	7	15	
CS	-0.3	0.5	
ZCS	-0.3	3.0	
COMP	-0.3	2.5	
FMAX	-0.3	2.5	
FAULT	-0.3	3.0	
Junction Temperature Range	-40	125	°C
Ambient Temperature Range	-40	85	°C

**Electrical Characteristics**

 (V<sub>VCC</sub> = 13V (Note 7), T<sub>A</sub> = 25°C unless otherwise specified)

Parameter (Note 4)	Symbol	Test Conditions	Min	Typ	Max	Unit	
HV	HV Current to Charge VCC	I <sub>HV_CHARGE1</sub>	V <sub>HV</sub> = 100V <sub>DC</sub> , V <sub>VCC</sub> = 0V	0.15	0.3	0.55	mA
			V <sub>HV</sub> = 100V <sub>DC</sub> , V <sub>VCC</sub> = 3V	2.6	4.0	5.4	mA
	Current to Discharge X Capacitor	I <sub>HV_XCAP</sub>		2.0		mA	
	High or Low Voltage Detection	HV <sub>TH_AC_HIGH</sub>		200	218	236	V
	AC Low Debounce Time	t <sub>AC_LOW_DBC</sub>		20		ms	
	Debounce Time to Detect AC Unplug	t <sub>UNPLUG_DBC</sub>		100		ms	
	BO Threshold	HV <sub>TH_BO</sub>		65	72	79	V
	BI Threshold	HV <sub>TH_BI</sub>			105		V
	BO Debounce Time	t <sub>BO_DBC</sub>		90		ms	
	Restart Time after BO	t <sub>ERROR_BO</sub>			0.25		s
BI Debounce Time	t <sub>BI_DBC</sub>			200		μs	
VCC	VCC Turn-On Threshold	V <sub>VCC_ON</sub>	V <sub>VCC</sub> rising	18	20	22	V
	VCC Turn-Off Threshold	V <sub>VCC_OFF</sub>	V <sub>VCC</sub> falling	7.5	8.0	8.5	V
	VCC Short Threshold	V <sub>VCC_SHORT_TH</sub>		0.5	0.7	0.8	V
	VCC Regulation Threshold	V <sub>VCC_REG</sub>		10	11	12	V
	VCC Regulation Hysteresis	V <sub>VCC_REGHYS</sub>			1.0		V
	Protection Timer after Error Trigger	t <sub>ERROR</sub>			1.0		s
	VCC OVP Threshold	V <sub>VCC_OVP</sub>	V <sub>VCC</sub> rising	26.4	28.0	29.6	V
	VCC OVP Debounce Cycles	N <sub>VCCOVP_DBC</sub>			4		
	VCC Shunt Threshold	V <sub>VCC_SHUNT</sub>		25	27	29	V
	VCC Shunt Current Capability	I <sub>VCC_SHUNT</sub>	V <sub>VCC</sub> > V <sub>VCC_SHUNT</sub>		10		mA
	Normal Operation Current Consumption	I <sub>CC_OPERATING</sub>	C <sub>L</sub> = open, f <sub>sw</sub> = 50kHz		1.2		mA
Standby Current Consumption	I <sub>CC_STANDBY</sub>	V <sub>COMP</sub> < V <sub>TH_SLEEP_IN</sub>	180	400	520	μA	
FMAX	Frequency Set	f <sub>MAX</sub>	R > 260kΩ R = 100kΩ R < 52kΩ or Floating	450	100 260 500	540	kHz
CS	Maximum Peak Current threshold	V <sub>CS_MAX</sub>	Secondary Side Diode or SR Short	685	720	755	mV
	Leading Edge Blanking for V <sub>CS_MAX</sub>	t <sub>CS_LEB1</sub>			150		ns
	Delay Time from V <sub>CS_MAX</sub> to PWM Off	t <sub>CSMAX_DELAY</sub>			30		ns

Parameter (Note 4)	Symbol	Test Conditions	Min	Typ	Max	Unit	
CS	V <sub>CS_MAX</sub> Cycles	N <sub>VCSMAX_DBC</sub>		4			
	V <sub>CS</sub> Limit	V <sub>CS_LIMIT</sub>	475	500	525	mV	
	Leading Edge Blanking for V <sub>PK</sub> and V <sub>CS_LIMIT</sub>	t <sub>CS_LEB2</sub>		250		ns	
	OCP Threshold Normal	V <sub>REF_OCPNORMAL</sub>	805	850	895	mV	
	OCP Threshold LPS High	V <sub>REF_OCPLPSH</sub>	V <sub>ZCS</sub> < V <sub>ZCSLPS_LOW</sub>	805	850	895	mV
	OCP Threshold LPS Low	V <sub>REF_OCPLPSL</sub>	V <sub>ZCS</sub> > V <sub>ZCSLPS_HIGH</sub>	470	495	520	mV
	OCP Debounce Time	t <sub>IOUTOCP_DBC</sub>		200		ms	
	Delay Time from V <sub>CS_LIMIT</sub> to DRV Falling	t <sub>CS_DELAY2</sub>		30		ns	
	Delay Time from V <sub>PK</sub> Control to DRV Falling	t <sub>CS_DELAY3</sub>		30		ns	
	V <sub>CS</sub> Minimum in DCM	V <sub>CSMIN_DCM</sub>	65	80	95	mV	
	Soft-Start Time	t <sub>SST</sub>		10		ms	
	QR Mode Frequency of Modulation	f <sub>MODULATION_QR</sub>		4		kHz	
	V <sub>CSPK</sub> Modulation Amplitude in QR Mode	V <sub>QR_MODULATION1</sub>	Valley = 1–3		20		mV
			Valley = 4–6		30		mV
	CS Short-Circuit Protection	V <sub>CS_SHORT</sub>	t <sub>ON</sub> = 6.2μs		60		mV
	Restart Time after CS Short Circuit	t <sub>ERROR_CSSHORT</sub>			0.25		s
Current Mirror In t <sub>ON</sub>	V <sub>CS_MIRROR</sub>	I <sub>ZCS</sub> :I <sub>CS</sub>		12:1		/	
ZCS	OVP Threshold	V <sub>ZCS_OVP</sub>	2.36	2.50	2.64	V	
	OVP Threshold Debounce Cycles	N <sub>ZCSOVP_DBC</sub>		4			
	UVP Threshold	V <sub>ZCS_UVP</sub>		150		mV	
	UVP Threshold Debounce Time	t <sub>OUTUVP_DBC</sub>		20		ms	
	Maximum Value of Off Blanking Time	t <sub>ZCSLEB_MAX</sub>	1.6	2.3	3.0	μs	
	Minimum Value of Off Blanking Time	t <sub>ZCSLEB_MIN</sub>	0.65	0.9	1.3	μs	
	Maximum Off-Time	t <sub>OFF_MAX</sub>	90	120	150	μs	
	Zero-Cross Point	V <sub>ZCS_ZERO</sub>		0		mV	
	QR Turn-On Delay	t <sub>ZCS_ONDELAY</sub>		100		ns	
	LPS High Point	V <sub>ZCSLPS_HIGH</sub>	1.74	1.90	1.98	V	
	LPS Low Point	V <sub>ZCSLPS_LOW</sub>	1.06	1.12	1.24	V	
Fault	Current Source for OTP Detection	I <sub>OTP</sub>	46.5	49.0	51.5	μA	
	OTP Threshold	V <sub>OTP_TH</sub>	0.37	0.40	0.43	V	
	OTP Exit Threshold	V <sub>OTPEXIT_TH</sub>		0.45		V	
	Clamp Diode for OVP	V <sub>OVPDIODE</sub>	1.1	1.3	1.5	V	
	Capability of Clamp Diode for OVP	I <sub>FAULT_OVP</sub>		1		mA	
	OVP Threshold	V <sub>OVP_TH</sub>		2.5		V	

Parameter (Note 4)	Symbol	Test Conditions	Min	Typ	Max	Unit	
Debounce Time to Trigger OTP/OVP	t <sub>FAULTOTP/OVP_DBC</sub>	V <sub>FAULT</sub> < V <sub>OTP_TH</sub> V <sub>FAULT</sub> > V <sub>OVP_TH</sub>		100		μs	
COMP	Internal Pullup Voltage	V <sub>COMP_PULLUP</sub>	2.2	2.5	2.8	V	
	Internal Pullup Resistor	R <sub>COMP_PULLUP</sub>		20		kΩ	
	V <sub>CS_LIMIT</sub> Point	V <sub>COMP_LIMIT</sub>		1.9		V	
	QR Mode to DCM Change Threshold	V <sub>COMP<sub>TH</sub>_DCM</sub>		1.0		V	
	Hysteresis of QR Mode to DCM	V <sub>COMP<sub>TH</sub>_DCMHYS</sub>		0.1		V	
	Minimum Switching Frequency Threshold	V <sub>COMP_FMIN</sub>		0.55	0.7	0.85	V
COMP	Enter Burst Mode Threshold	V <sub>COMP_BURSTIN</sub>	V <sub>COMP</sub> falling	0.19	0.25	0.31	V
	Exit Burst Mode Threshold	V <sub>COMP_BURSTOUT</sub>	V <sub>COMP</sub> increasing		0.45		V
	Start PWM Threshold in Burst Mode	V <sub>COMP_BURSTSTART</sub>	V <sub>COMP</sub> increasing		0.35		V
	Burst Frequency	V <sub>COMP_BURSTFREQ</sub>			1		kHz
	OLP Threshold	V <sub>COMP_OLP</sub>	V <sub>COMP</sub> rising	1.95	2.2	2.45	V
	OLP Debounce Time	t <sub>OLP_DBC</sub>	V <sub>COMP</sub> > V <sub>COMP_OLP</sub>		50		ms
DRV	High Voltage Clamp	V <sub>DRV-CS_CLAMP</sub>	12.0	13.5	15.0	V	
	Programmable Driver Current	I <sub>DRV</sub>	DVR-GND: 43kΩ		10		mA
			DVR-GND: 22kΩ		20		mA
			DVR-GND: 10kΩ		40		mA
			DVR-GND: < 2kΩ		Not supported		
	Sink Current	I <sub>DRV_SINK</sub>		800		mA	
	Maximum t <sub>ON</sub>	t <sub>ON_MAX</sub>		14	20	26	μs
	Frequency Limit in DCM Mode	f <sub>LIMIT_DCM</sub>			75		kHz
	Frequency Minimum in DCM Mode	f <sub>MIN_DCM</sub>		20	25	32	kHz
DCM Mode Modulation Frequency	f <sub>MODULATION_DCM</sub>			250		Hz	
Minimum Valley Number in QR Mode	VALLEY <sub>NUMBER</sub>	HV < 218V	1		6		
		HV > 218V	1		6		
Internal OTP	OTP Threshold (Note 5)	T <sub>OVP_SHUTDOWN</sub>		150		°C	
	Recovery Threshold (Note5)	T <sub>OVP_RECOVERY</sub>		130		°C	

**Note 1:** Stresses beyond the “Absolute Maximum Ratings” may cause permanent damage to the device. These are stress ratings only. Functional operation of the device at these or any other conditions beyond those indicated in the operational sections of the specification is not implied. Exposure to absolute maximum rating conditions for extended periods may affect device reliability.

**Note 2:** θ<sub>JA</sub> is measured in the natural convection at TA = 25°C on a low effective single layer thermal conductivity test board of JEDEC 51-3 thermal measurement standard. Test condition: Device mounted on “2 x 2” FR-4 substrate PCB, 2oz copper, with minimum recommended pad on top layer and thermal via to bottom layer ground plane.

**Note 3:** The device is not guaranteed to function outside its operating conditions.

**Note 4:** Unless otherwise stated, limits are 100% production tested under pulsed load conditions such that  $T_A \cong T_J = 25C$ . Limits over the operating temperature range (See recommended operating conditions) and relevant voltage range(s) are guaranteed by design, test, or statistical correlation.

**Note 5:** Guaranteed by design or statistical correlation and not production tested.

**Note 6:** Meets ESDA/JEDEC JS-001-2017 and JEDEC78E.

**Note 7:** Increase VCC pin voltage higher than  $V_{CC\_ON}$  (max) voltage, then reduce it to 13V.

## Detailed Description

### HV Startup and Power Supply

The HV pin charges the VCC capacitor at AC power-on. When VCC voltage rises above the startup threshold, the HV circuits will be turned off to reduce power loss.

In situations when the device enters protection mode, the PWM operation is stopped for a  $t_{ERROR}$  time. Because of the power consumption during  $t_{ERROR}$ , the VCC capacitor voltages will drop. When VCC falls to  $V_{CC\_REG}$ , HV circuitry is enabled again to charge the capacitors until  $V_{CC} > (V_{CC\_REG} + V_{CC\_REGHYS})$ . After  $t_{ERROR}$ , the internal logic will be reset, and a restart sequence is initiated.

### QR Mode (Automatically Selected Valley Number between 1 and 6)

In QR mode, PWM turns on at the valley point of the MOS FET drain voltage. This improves EMI and efficiency.  $V_{CSPK}$  is controlled by  $V_{COMP}$ , and the valley number is controlled by the output load. When  $V_{COMP}$  is higher than  $(V_{COMP\_THDCM} + V_{COMP\_THDCMHYS})$ , QR mode is enabled and starts on the 6<sup>th</sup> valley number. As the load increases, the valley number decreases in one-step increments until it reaches the minimum value.

### Valley Detect

The waveform in Figure 3 shows the valley detection method. When the falling edge of the zero-crossing voltage appears at the ZCS pin, the SQ33020 will turn on the MOS FET after a delay.

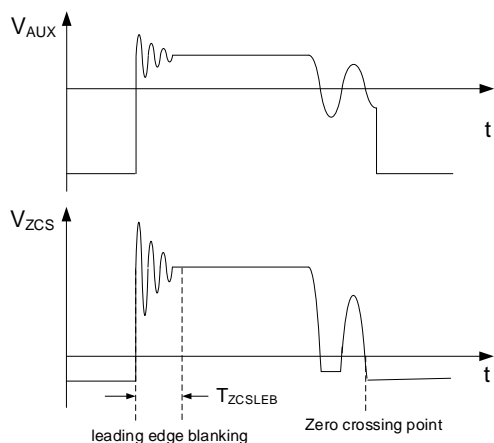

Figure 3. Valley Detection

Noise is present at the ZCS pin when the MOS FET turns off, which may affect valley detection. The SQ33020 uses a blanking time to avoid noise interference, which is described in the *Output OVP and UVP* section.

### DCM Mode

When  $V_{COMP}$  is lower than  $V_{COMP\_TH\_DCM}$ , DCM mode is enabled. In DCM mode,  $V_{CSPK}$  and the switching frequency are controlled by  $V_{COMP}$ . PWM turns on

instantly at  $f_{sw}$  and does not wait for the valley point. As load decreases, the frequency first decreases from  $f_{LIMIT\_DCM}$  to  $f_{MIN\_DCM}$ , and the device switches operation to PFM mode to maintain high efficiency. When the frequency has decreased to  $f_{MIN\_DCM}$  and the load continues decreasing,  $V_{CSPK}$  begins decreasing to maintain constant output voltage.

### Burst Mode

When frequency and  $V_{CSPK}$  have decreased to their respective minimum values, if the output load continues decreasing,  $V_{COMP}$  becomes lower than  $V_{COMP\_BURSTIN}$ . In this case the device starts operating in Burst mode. PWM will start when  $V_{COMP}$  is higher than  $V_{COMP\_BURSTSTART}$ . The PWM number of switching cycles is controlled by  $t_{BURST}$  in order to keep burst frequency lower than the set value. PWM operation will continue until the set number of cycles are completed. PWM then stops and waits for the next rising edge of  $V_{COMP\_BURSTSTART}$ . With this method, the burst frequency is low, and audible noise is reduced.

When  $V_{COMP}$  is higher than  $V_{COMP\_BURSTOUT}$ , the SQ33020 will enter DCM mode.

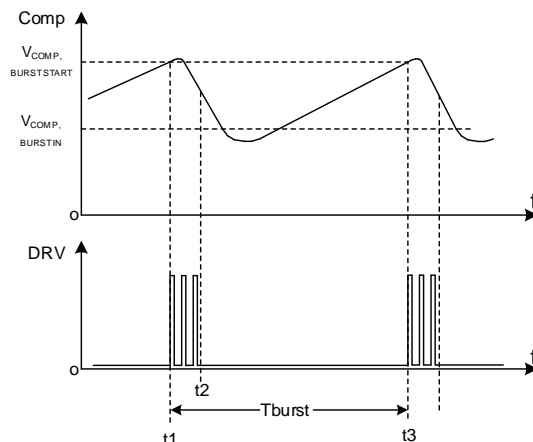

Figure 4. Quiet Burst

### VCC Power Supply

Figure 5 shows a typical VCC supply circuit. During the X capacitor discharge process, C11 voltage will be charged to  $V_{CC\_SHUNT}$ . In this case, a 35V capacitor voltage rating is recommended.

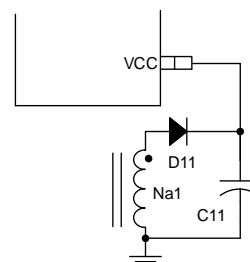

Figure 5. Typical Circuit for One-Winding Application

## Accurate Output Overcurrent Protection (OCP)

The SQ33020 detects output current at the primary side. The CS pin samples voltage across  $R_{CS}$  before PWM turn-off. When  $N_s$  winding current falls to zero, the ZCS pin records the demagnetization time. The SQ33020 calculates output current using these two signals, and the result is compared with  $V_{REF\_OCP}$  (internal threshold). When the result is higher than  $V_{REF\_OCP}$  for a period of  $t_{IOUT\_OCP\_DBC}$ , PWM stops and a timer begins. After time  $t_{ERROR}$  elapses, logic will be reset and HV will charge  $V_{CC}$  to  $V_{CC\_ON}$  for restart.

$I_{OUT\_OCP}$  can be set by  $R_{CS}$  with following formula.

$$I_{OUT\_OCP} = \frac{0.93 \times V_{REF\_OCP} \times N_{PS}}{6 \times R_{CS}}$$

where  $V_{REF\_OCP}$  is the internal voltage of SQ33020;  $N_{PS}$  is the transformer  $N_P/N_S$ ;  $R_{CS}$  is  $R_5$  shown in Figure 6.

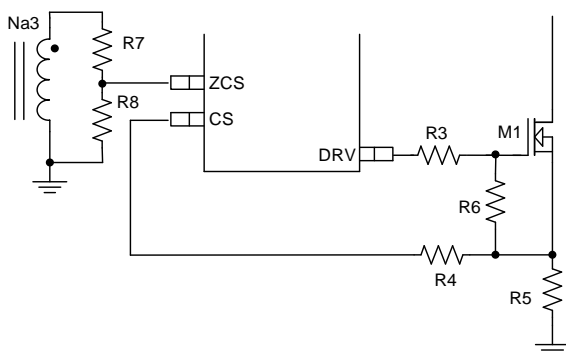

Figure 6. Typical Circuit for  $R_{CS}$  Calculation

The SQ33020 uses  $R_4$  to compensate the system error. If  $I_{OUT\_OCP}$  becomes higher with an input voltage increase,  $R_4$  should be increased. If  $I_{OUT\_OCP}$  falls with an input voltage increase, which indicates excess compensation,  $R_4$  should be reduced.

For applications where  $M_1$  is a super junction MOS, the  $R_4$  recommended value is between  $1k\Omega$  to  $3k\Omega$ . When  $M_1$  is a GaN FET, such as NV611x and NV612x, the  $R_4$  recommended value is between  $200\Omega$  to  $1k\Omega$ .

## Output OCP Modes

In quick charge applications,  $V_{OUT}$  range is usually very wide (3.3V to 21V, for example).  $I_{OUT}$  range is also very wide. The SQ33020 provides two OCP options to accommodate different applications.

The first option is Normal OCP mode. This mode is suitable when the current limit doesn't change for different output voltages. Output voltage and current selections include the following: 5V/3A, 9V/3A, 12V/3A, 15V/3A, 20V/3.25A, 3.3V–21V/3A.

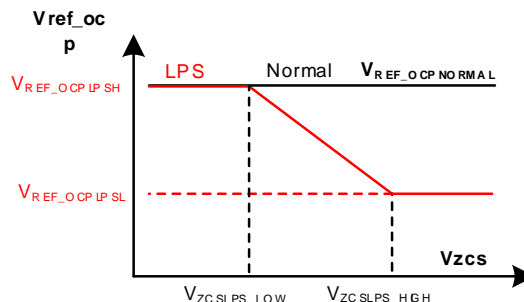

Figure 7. Two Output OCP Modes

The second option is limited power source (LPS) OCP mode. This mode of operation is suitable for applications where the overall power delivered is used to determine the OCP threshold, according to the programmed output voltage. If Normal OCP option would be used, in some cases the OCP threshold could expose the part to unsafe power levels. For example, assuming that  $I_{OUT\_OCP}$  is set to 7.0A, when  $V_{OUT}$  is changed to 20V, maximum output power will be 140W. This is prohibited in UL60950 or later safety standards.

The SQ33020's LPS OCP option is suitable for operating the part reliably across all operating conditions.  $V_{REF\_OCP\_LPS}$  is related to  $V_{OUT}$ , and  $I_{OUT\_OCP}$  can be set by  $R_{CS}$  when  $V_{OUT}$  is highest. When  $V_{OUT}$  is lower,  $V_{REF\_OCP\_LPS}$  becomes higher. At  $V_{OUT} = 10V$ ,  $I_{OUT\_OCP}$  is higher than 6.5A and a 10V/6.5A load won't trigger output OCP.

Typical output voltage and current selections include the following: 5V/3A, 9V/3A, 10V/6.5A, 12V/5A, 15V/4A, 20V/3.25A, and 5V-12V/5A.

## X Capacitor Discharge and Output OCP using the ZCS Resistor

The X capacitor discharge and Output OCP functions can be selected using the ZCS resistor. When the X capacitor is enabled, HV should be connected to the AC line via two diodes. When the X capacitor is disabled, HV can be connected to  $V_{BUS}$  to eliminate the diodes and reduce solution cost.

Table 1. ZCS Resistors Configuration

ZCS Pulldown (R8)	X Capacitor Function	Output OCP
25–27k $\Omega$ $\pm$ 1%	Disabled	Normal
13k $\Omega$ $\pm$ 1%	Enabled	Normal
7.5k $\Omega$ $\pm$ 1%	Disabled	LPS
3.0–3.6k $\Omega$ $\pm$ 1%	Enabled	LPS

The ZCS\_OVP threshold is 2.50V. With  $R_8$  selected,  $R_7$  can be calculated according to  $V_{OUT\_OVP}$  and  $N_A/N_S$ . Resistor  $R_4$ , in series with  $CS$ , should be adjusted as well. If  $I_{OUT\_OCP}$  (user selected) increases according to  $V_{AC}$

rising, the value of R4 should be increased for more compensation.

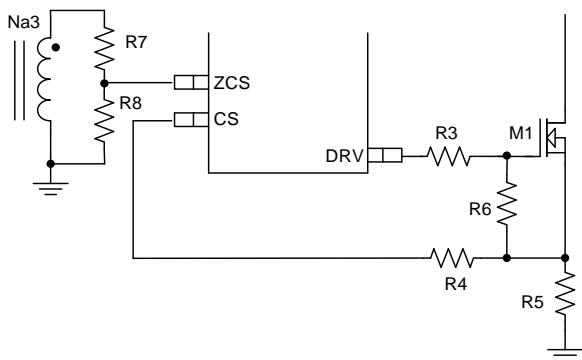

Figure 8. X Capacitor and Output OCP using ZCS Resistor

### Programmable Drive Current

During turn-on, the SQ33020 uses constant current to charge the input M1 capacitance,  $C_{gs}$ , and improve EMI performance. During turn-off, the DRV pin will be pulled down quickly to reduce turn-off loss. Traditional drive resistors and diodes are not required. R3 is used to make slight adjustments to the turn-off speed. The recommended value of R3 is 10Ω–30Ω.

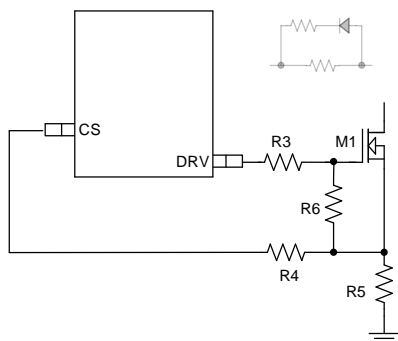

Figure 9. MOSFET Drive Circuit

At turn-on, the constant current value can be selected using R6 based on Table 2:

Table 2. R6 and Constant Current Value

R6	Constant Current
10kΩ	40mA
22kΩ	20mA
43kΩ	10mA
<2kΩ	Not Supported

The device enters protection mode for R6 values below 2kΩ where PWM switching is disabled.

Using a lower current, the MOS turn-on speed will be slower and EMI performance will be better. The R6 value is measured during startup, and the current value is fixed until the next startup.

### Frequency Limit Curve

For QR mode operation, when load decreases, switching frequency will increase. This will also increase switching loss, so the FMAX pin can be used to limit the maximum frequency. The relationship between frequency limit and the FMAX pin resistor is shown in Figure 10.

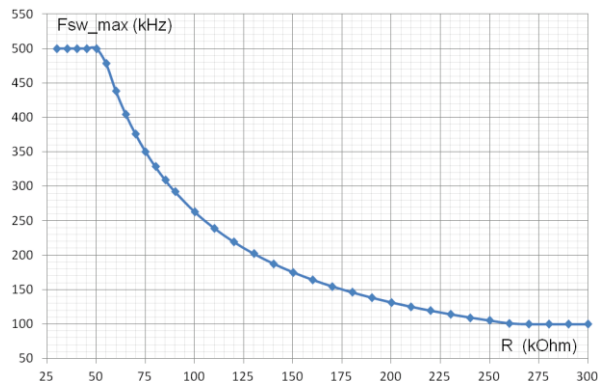

Figure 10. Frequency Limitation Curve

When the FMAX pin is floating, or if the resistor is lower than 30kΩ, the frequency limit is 500kHz. When frequency limit is triggered, PWM will turn on at the next valley.

### Frequency Modulation

In QR mode, the SQ33020 adds a triangle voltage on  $V_{cs}$  for frequency modulation. If the valley number is between 1 and 3, the modulation amplitude is set to 20mV. If the valley number is between 4 and 6, the modulation amplitude is set to 30mV in order to obtain an effective range of frequency modulation.

### Soft-Start

At startup, when  $V_{COMP}$  rises to  $V_{COMP\_BURSTSTART}$ , PWM operation starts and  $V_{CS}$  increases from the minimum value linearly. Under heavy load or  $V_{OUT}$  short conditions, soft-start will terminate after a period of  $t_{SST}$ . Under light load or no-load conditions, when the  $V_{CS}$  value determined by  $V_{COMP}$  is lower than the value determined by soft-start, soft-start will terminate and  $V_{COMP}$  will control  $V_{CS}$ .

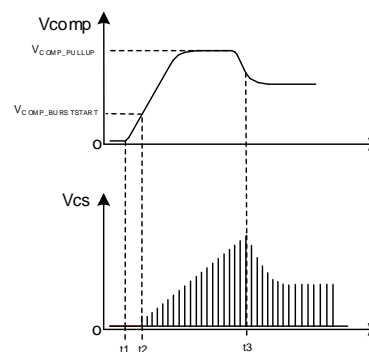

Figure 11. Soft-Start Process

Under startup or  $V_{OUT}$  short conditions,  $V_{OUT}$  and ZCS are very low. If ZCS cannot detect an effective valley signal,  $t_{OFF\_MAX}$  will be enabled. This is helpful to reduce the voltage stress on the SR MOSFET  $V_{DS}$ .

### V<sub>CS</sub>\_LIMIT

After time  $t_{CS\_LEB2}$  in each cycle, when  $V_{CS}$  is higher than  $V_{CS\_LIMIT}$ , PWM will turn off immediately. The decision is made cycle by cycle and will not affect the next cycle's PWM on-time.

### V<sub>CS</sub>\_MAX Protection

Under normal operating conditions,  $V_{CS\_LIMIT}$  can limit MOS peak current and provide sufficient protection. When the transformer winding or the secondary diode short circuits, the current slope is very high and the transformer will enter saturation state. In this situation, the current can rise to a much higher level during  $t_{CS\_LEB2}$ . The SQ33020 can detect  $V_{CS}$  after  $t_{CS\_LEB1}$ , which is shorter than  $t_{CS\_LEB2}$ . If  $V_{CS}$  is higher than  $V_{CS\_MAX}$  for four consecutive cycles, PWM operation stops and the timer starts. After  $t_{ERROR}$ , the logic is reset and a restart is triggered, with HV charging  $V_{CC}$  to  $V_{CC\_ON}$ .

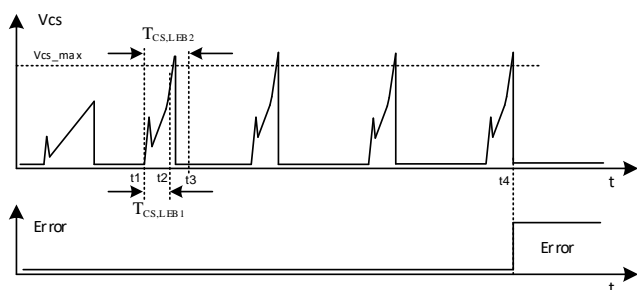

Figure 12.  $V_{CS\_MAX}$  Process

### Brown-In and Brown-Out

When input voltage is lower than 90V AC, current and heat dissipation on the transformer and primary MOSFET are very high. The SQ33020 provides brown-in (BI) and brown-out (BO) protections to protect the power supply. Brown-in and brown-out are defined as follows:

- BI: HV voltage is higher than  $HV_{TH,BI}$  and lasts for  $t_{BI,DBC}$
- BO: HV voltage is lower than  $HV_{TH,BO}$  and lasts for  $t_{BO,DBC}$

After a BO event, PWM stops. Then, after a  $t_{ERROR\_BO}$  delay, the logic is reset and a startup sequence is initiated, with the HV input charging  $V_{CC}$  to  $V_{CC\_ON}$ .

### X Capacitor Discharge

Under light load, when the charger is unplugged from the AC source, there may be remaining high voltage on the input terminals, which can present a safety concern. The SQ33020 uses the HV pin to discharge the X capacitor. HV is connected to the AC side through R1, D1,

and D3. The recommended R1 value is 1kΩ–10kΩ, which protects against surge voltages on the AC line.

If there is no HV rising edge for continuous time  $t_{UNPLUG\_DBC}$ , an AC unplug condition is detected and PWM stops. HV sources an  $I_{HV\_XCAP}$  current to the VCC pin. As a result, VCC rises to  $V_{CC\_SHUNT}$  and HV falls linearly. When VCC becomes lower than  $V_{CC\_OFF}$ , the discharge stops.

The voltage rating of the VCC capacitor should be higher than  $V_{CC\_SHUNT}$ . A 35V voltage rating is recommended. During X capacitor discharge, when a rising edge on HV (indicating AC re-plug) is detected, the discharge is terminated immediately. The  $t_{ERROR}$  timer continues. During  $t_{ERROR}$ , HV keeps VCC between  $V_{CC\_REG}$  and  $(V_{CC\_REG} + V_{CC\_REGHYS})$ . After a  $t_{ERROR}$  delay, the logic will be reset and a startup sequence is initiated, with the HV input charging  $V_{CC}$  to  $V_{CC\_ON}$ .

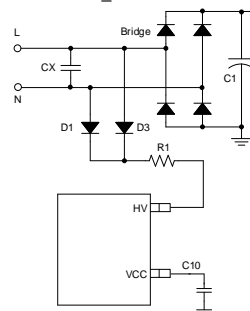

Figure 13. X Capacitor Discharge Circuit

Figure 14 shows the discharge waveforms:

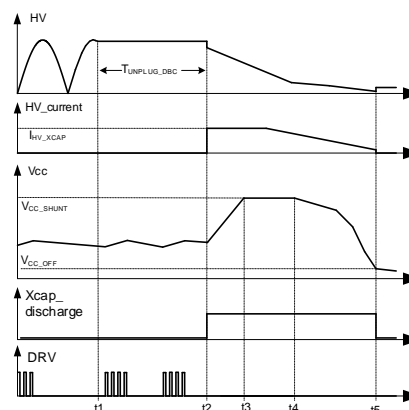

Figure 14. X Capacitor Discharge Waveforms

- At t1, AC unplug occurs.
- At t2, AC unplug is confirmed. PWM stops and HV sources current to  $V_{CC}$ .
- At t3,  $V_{CC}$  rises to  $V_{CC\_SHUNT}$ .
- At t4, X capacitor discharge current is lower than  $V_{CC}$  dissipation and  $V_{CC}$  begins falling.
- At t5,  $V_{CC}$  is lower than  $V_{CC\_OFF}$  and the discharge stops.

## Output Overvoltage and Undervoltage Protection

The SQ33020 detects the output voltage through the ZCS pin and provides output overvoltage protection (OVP) and undervoltage protection (UVP). There is parasitic resonance on the AUX winding when the primary MOSFET turns off, so the SQ33020 uses blanking time to avoid false triggering. Blanking time is adaptive according to  $V_{CSPK}$ . When  $V_{CSPK}$  is below 200mV, primary current is low and energy stored in leakage inductance is also low. Parasitic resonance on auxiliary winding will be shorter, so blanking time is also shorter. Blanking time increases to the maximum value as  $V_{CSPK}$  rises to 500mV.

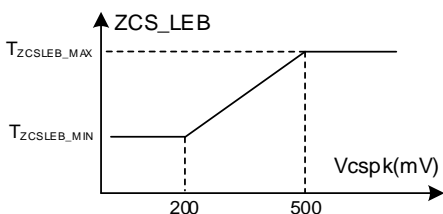

Figure 15. ZCS Blanking Time

When ZCS voltage is higher than  $V_{ZCS\_OVP}$  for  $N_{ZCSOVP\_DBC}$  cycles, ZCS\_OVP is triggered and PWM stops. After a  $t_{ERROR}$  delay, the logic is reset and a startup sequence is initiated, with the HV input charging  $V_{CC}$  to  $V_{CC\_ON}$ .

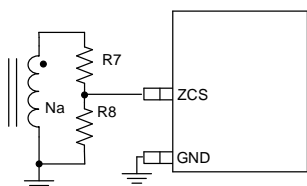

Figure 16. ZCS OVP Setting

The output OVP threshold is calculated as follows:

$$V_{OUT\_OVP} = V_{ZCS\_OVP} \times \frac{R7 + R8}{R8} \times \frac{Ns}{Na}$$

When ZCS voltage is lower than  $V_{ZCS\_UVP}$  continuously for a period of  $t_{VOUTUVP\_DBC}$ , ZCS\_UVP is triggered and PWM stops. After a  $t_{ERROR}$  delay, the logic is reset and a startup sequence is initiated, with the HV input charging  $V_{CC}$  to  $V_{CC\_ON}$ .

**Note:** The pull-down resistor R8 value should be selected first, based on use of the X capacitor and output OCP settings. Then, R7 should be calculated according to the above equation. UVP is used to avoid continuous operation under  $V_{OUT}$  short-circuit conditions and is not mandatory for the design.

## VCC Overvoltage Protection

The SQ33020 provides  $V_{CC}$  overvoltage protection (OVP) to protect the IC from abnormal high voltage caused by an open feedback loop or improper  $N_A$  winding. When  $V_{CC}$  rises to  $V_{CC\_SHUNT}$  and external power current capability is higher than the shunt ability,  $V_{CC}$  can continue rising.

$V_{CC}$  is continuously monitored. If  $V_{CC}$  is higher than  $V_{CC\_OVP}$  for four continuous cycles,  $V_{CC}$  OVP is triggered and PWM stops. After a  $t_{ERROR}$  delay, the logic is reset and a startup sequence is initiated, with the HV input charging  $V_{CC}$  to  $V_{CC\_ON}$ .

If the error condition still exists after restart, the IC will operate in hiccup mode.

## Open-Loop Protection

If the output is short-circuited, the optocoupler circuit is open, or the load increases too much,  $V_{COMP}$  will increase. When  $V_{COMP}$  is higher than  $V_{COMP\_OLP}$  and lasts for  $t_{OLP\_DBC}$ , open-loop protection (OLP) is triggered and PWM stops. After a  $t_{ERROR}$  delay, the logic is reset and a startup sequence is initiated, with the HV input charging  $V_{CC}$  to  $V_{CC\_ON}$ .

## FAULT Overtemperature and Overvoltage Protection

The FAULT pin can be used for detecting overvoltage (OVP) and overtemperature (OTP) protection conditions. During normal operation, the current of  $I_{OTP}$  is clamped by D12. D12 clamp voltage is selected to be between the OTP threshold and the OVP threshold. Therefore, neither protection is triggered.

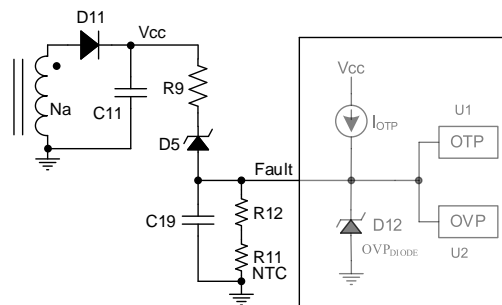

Figure 17. Fault OTP and OVP

Under error conditions,  $V_{CC}$  will rise. In this case, if D5 also fails, the pull-up current might exceed D12 clamp capability and the FAULT pin voltage will be pulled up. When the FAULT pin is higher than  $V_{OVP\_TH}$  and lasts for a period of  $t_{FAULTOTP/OVP\_DBC}$ , FAULT OVP is triggered and PWM stops. After a  $t_{ERROR}$  delay, the logic is reset and a startup sequence is initiated, with the HV input charging  $V_{CC}$  to  $V_{CC\_ON}$ .

R11 is a negative temperature coefficient (NTC) resistor. As temperature rises, R11 resistance falls. When R11 resistance is low enough, there will be no current flowing into D12 and the  $I_{OTP}$  current will flow into R11. As  $I_{OTP}$  does not change, FAULT voltage will fall along with R11

resistance. When FAULT voltage is lower than  $V_{OTP\_TH}$ , FAULT OTP is triggered and PWM stops. After a  $t_{ERROR}$  delay, the logic is reset and a startup sequence is initiated, with the HV input charging  $V_{CC}$  to  $V_{CC\_ON}$ . After restart, the FAULT pin is monitored, and PWM will not begin until FAULT voltage is higher than  $V_{OTPEXIT\_TH}$ .

R9 is used to limit the current flowing into the FAULT pin. The OVP threshold is primarily decided by D5 breakdown voltage. R12 is used to adjust the OTP threshold slightly. C19 is used to filter noise, with a recommended value of 100pF.

### CS Pin Short Circuit

During  $t_{ON}$  of every PWM cycle,  $V_{CS}$  is sampled every 6.2 $\mu$ s and compared with  $V_{CS\_SHORT}$ . If  $V_{CS} < V_{CS\_SHORT}$ , short-circuit protection is triggered and PWM stops. After a  $t_{ERROR\_CSSHORT}$  delay, the logic is reset and a startup sequence is initiated, with the HV input charging  $V_{CC}$  to  $V_{CC\_ON}$ .

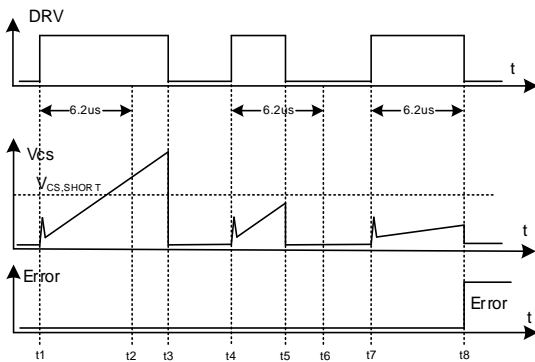

Figure 18. CS Short Protection

Figure 18 shows the short-circuit protection logic:

- At  $t_2$ ,  $V_{CS}$  is higher than  $V_{CS\_SHORT}$ . No protection.
- At  $t_5$ , the 6.2 $\mu$ s timer has not expired. No comparison is needed. No protection.
- At  $t_8$ ,  $V_{CS}$  is lower than  $V_{CS\_SHORT}$  at 6.2 $\mu$ s mark. Protection is triggered.

### Internal OTP

The SQ33020 continuously monitors the die temperature during normal operation. When the die temperature rises above the OTP threshold, PWM stops. After a  $t_{ERROR}$  delay, the logic is reset and a startup sequence is initiated, with the HV input charging  $V_{CC}$  to  $V_{CC\_ON}$ .

## Design Guide

### BUS Capacitor Calculation

Generally, bulk capacitor  $C_{BUS}$  is selected according to the following rules:

- No PFC: 1.5–1.8 $\mu$ F per watt (output power)
- With PFC: 0.5–0.8 $\mu$ F per watt (output power)

### Minimum BUS Voltage Calculation

Minimum BUS voltage occurs when input voltage  $V_{AC}$  is lowest and output current reaches its rated value. When there is no power factor correction (PFC) circuit before the flyback, minimum BUS voltage is calculated as follows:

$$V_{BUS\_MIN} = \sqrt{2V_{IN\_MIN}^2 - \frac{P_o(1-K_{CH})}{\eta C_{BUS} f_o}}$$

where  $K_{CH}$  is the BUS capacitor charge coefficient (generally  $K_{CH}$  is set to 0.2–0.3);  $\eta$  is conversion efficiency;  $f_o$  is the AC input frequency.

When selecting the necessary capacitors, the following aspects must be considered:

- The actual capacitance for aluminum capacitors is only 85-90% of nominal value
- Component tolerance

The following examples are helpful for fast selection and can be used as a reference.

- 30W solution, with no boost PFC circuit. Bus nominal capacitance is 27 + 27 $\mu$ F.  $V_{BUS\_MIN}$  is as follows:

Output Power	30W	35W	40W	45W
AC90V 50Hz	86V	80V	75V	68V
AC90V 60Hz	93V	87V	83V	78V

For optimal performance,  $V_{BUS\_MIN}$  should be higher than 80V.

- 66W solution, no boost PFC circuit. Under full load 20V, 3.3A,  $V_{BUS\_MIN}$  is as follows:

Bus Nominal Capacitance	82+22 $\mu$ F	82+10 $\mu$ F	82 $\mu$ F	68 $\mu$ F
AC90V 50Hz	82V	78V	72V	60V

For optimal performance,  $V_{BUS\_MIN}$  should be higher than 80V.

- 140W solution, boost + flyback topology. Output is 28V, 5A. Bus nominal capacitance is 39+39 $\mu$ F.
  - At AC90V 50Hz, boost PFC outputs DC240V.  $V_{BUS}$  is 222V(min) to 253V(max). Ripple is 31V.
  - At AC176V 50Hz, boost PFC outputs DC350V.  $V_{BUS}$  is 338V(min) to 362V(max). Ripple is 24V.

### Transformer Parameters Calculation

#### 1. Primary/secondary turns ratio: $N_{PS}$

$N_{PS}$  is limited by voltage stress on the primary MOSFET

$$N_{PS} \leq \frac{V_{MOS\_BR} K_{DR} - \sqrt{2} V_{IN\_MAX} - \Delta V_{SN}}{V_o + V_{D\_F}}$$

where  $V_{MOS\_BR}$  is the breakdown voltage of the primary MOSFET;  $K_{DR}$  is the  $V_{DS}$  de-rating factor of the power MOS;  $V_{IN\_MAX}$  is always AC264V;  $V_{D\_F}$  is

the forward voltage of the secondary rectification diode (If SR is used on the secondary side, use  $V_{D,F} = 0$ );  $\Delta V_{SN}$  is the voltage spike at primary MOS turn-off. A starting value of 50V can be used for the calculation.

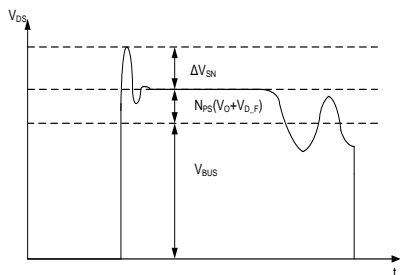

Figure 19. Primary  $V_{DS}$  Waveform

After  $N_{PS}$  is determined, the reflected voltage can be calculated as follows:

$$V_{OR} = N_{PS} \times (V_O + V_{D,F})$$

## 2. Primary Inductance: $L_P$

The SQ33020 provides operates in QR and DCM modes (CCM is not available). The transformer primary inductance is mainly related to switching frequency. With  $V_{BUS}$  being at its minimum value,  $L_P$  can be calculated as follows:

$$L_P = \frac{1}{2 \times f_{SW\_MIN} \times V_O \times I_O} \times \left( \frac{V_{BUS\_MIN} \times V_{OR}}{V_{BUS\_MIN} + V_{OR}} \right)^2$$

where  $V_O$  is the output voltage and the unit is V;  $N_{PS}$  is the primary/secondary turns ratio;  $V_{BUS\_MIN}$  is the minimum voltage after the bridge (V);  $f_{SW\_MIN}$  is the frequency at  $V_{BUS\_MIN}$  (kHz);  $I_O$  is the output current (A);  $L_P$  is the primary inductance (mH).

The parameters  $V_O$ ,  $N_{PS}$ ,  $V_{BUS\_MIN}$  and  $I_O$  have been determined. Only  $f_{SW\_MIN}$  needs to be selected. When  $f_{SW\_MIN}$  is higher,  $L_P$  will be lower. The frequency for AC230V designs will also be higher.

For a typical application,  $f_{SW\_MIN}$  is approximately 100kHz-130kHz, at  $V_{BUS\_MIN}$  (usually 80V-90V). Then, frequency at  $V_{BUS\_MAX}$  (370V) is approximately 160kHz-220kHz.

## 3. Turns of primary winding: $N_P$

- Select the magnetic core and confirm the effective core area (AE)
- Select  $B_{MAX}$  for the magnetic core (0.32T–0.36T)
- Calculate primary  $R_{CS}$  (preliminary):

$$R_{CS} = \frac{0.93 \times V_{REF\_OCP} \times N_{PS}}{6 \times I_{OUT\_OCP}}$$

where  $V_{REF\_OCP}$  is the internal threshold,  $I_{OUT\_OCP}$  is the OCP threshold, which is selected based on the maximum output current. For example, if the maximum current required is 3A, then 3.3A can be used for  $I_{OUT\_OCP}$ .

- Calculate maximum primary peak current

$$I_{PPK\_MAX} = \frac{V_{CS\_LIMIT}}{R_{CS}}$$

where  $V_{CS\_LIMIT}$  is 0.5V.

- Calculate primary turns:  $N_P$

$$N_P = \frac{L_P \times I_{PPK\_MAX}}{B_{MAX} \times A_E}$$

## 4. Turns of secondary winding: $N_S$

$$N_S = \frac{N_P}{N_{PS}}$$

In the actual design, however,  $f_{SW\_MIN}$  is difficult to determine. If a random value is selected, later calculations may be difficult and this may be unsuitable to the transformer bobbin. The following flow is suggested for a reduced number of iterations and predictable results:

- Select transformer and AE
- Determine winding width of the bobbin
- Select  $N_S$  wire gauge
- Determine  $N_S$
- Determine  $V_{OR}$  and  $N_{PS}$
- Calculate  $N_P$
- Select  $N_P$  wire gauge
- Calculate  $R_{CS}$
- Calculate  $I_{PPK\_MAX}$
- Determine  $B_{MAX}$
- Calculate  $L_P$

With this procedure,  $f_{SW\_MIN}$  is not an input parameter. When  $L_P$  is calculated, the switching frequency  $f_{SW}$  is determined as well. This will always lead to a satisfactory design, and efficiency will always be close to optimal for a given transformer.

## 5. Turns of auxiliary winding: $N_A$

For fast-charge applications,  $V_{OUT}$  range is wide. Turns of AUX winding should take  $V_{OUT\_MAX}$  and  $V_{OUT\_MIN}$  into consideration.

Efficiency can be increased by using two AUX windings, if a slight increase in BOM cost is acceptable.

- AUXL can supply  $V_{CC}$  at  $V_{OUT\_MAX}$ .
- $18V < \frac{V_{OUT\_MAX}}{N_S} \times N_{AUXL} < 22V$
- AUXH can supply  $V_{CC}$  at  $V_{OUT\_MIN}$ .
- $10V < \frac{V_{OUT\_MIN}}{N_S} \times N_{AUXH} < 14V$

In low-cost applications, one winding (AUXH) is sufficient. The number of turns for the AUXH winding is the same as  $N_{AUXH}$  in the above formula.

## Secondary Rectifier MOSFET Selection

Under the conditions of  $V_{BUS\_MAX}$  and  $V_{OUT\_OVP}$ , the reverse voltage of the secondary rectification MOSFET will reach its maximum level. The maximum voltage (ignoring the voltage spike when the primary MOSFET is turned on) is calculated as follows:

$$V_{D\_R\_MAX} = \frac{\sqrt{2}V_{IN\_MAX}}{N_{PS}} + V_{O\_OVP}$$

Maximum instantaneous forward current is calculated as follows:

$$I_{SPK\_MAX} = I_{PPK\_MAX} \times N_{PS}$$

- For a 66W (20V, 3.3A) solution, BSC098N10NS5 is recommended, which has 100V, 8.2m $\Omega$  ( $V_{GS} = 10V$ ) ratings.
- For a 90W (20V, 4.5A) solution, BSC0805LS is recommended, which has 100V, 6.0m $\Omega$  ( $V_{GS} = 10V$ ) ratings.
- For a 120W (20V, 6.0A) solution, two MOSFETs in parallel are recommended, primarily for heat dissipation. Using two BSC098N10NS5, which has 100V, 8.2m $\Omega$  ( $V_{GS} = 10V$ ) ratings.

Ensure that the selected MOSFET can dissipate the heat without exceeding the target acceptable temperature increase. Validate the design by performing temperature measurements under worst-case load and ambient temperature conditions.

## Layout Considerations

Follow these PCB layout guidelines for optimal performance and EMI considerations:

- Signals are grouped into two categories:
  - Switching nodes: primary drain/AUX/core; secondary drain/AUX/core.
  - Important signal nodes (easily disturbed):
    - Primary: CS, FAULT, comp, ZCS,  $f_{MAX}$ , etc.
    - Secondary: REG, TZ (TZ pin of SQ33239), feedback loop, etc.
- To guarantee normal operation, important signal nodes should be as far as possible from switching nodes. If PCB routing is difficult, static nodes should be used as shielding between switching and signal nodes. Static nodes can be  $V_{BUS}$ , GND, VCC, VCCH,  $V_{OUT}$ , SGND, etc.
- In order to optimize EMI performance, switching nodes on the PCB layout should be as small as possible. Switching nodes should not be selected for heat sinking, such as MOS drain.
- In order to obtain good EMI performance, the following current loops should be as small as possible:
  - Current path during  $t_{ON}$ : bus capacitor  $\rightarrow$  transformer  $\rightarrow$  MOS  $\rightarrow$   $R_{CS}$   $\rightarrow$  GND  $\rightarrow$  bus capacitor
  - Current path during  $t_{OFF}$  time: transformer  $\rightarrow$  SR\_MOS  $\rightarrow$   $C_{OUT}$   $\rightarrow$  GND  $\rightarrow$  transformer
  - Current in leakage inductance and snubber circuit
  - Drive loop of primary and secondary MOSFETs
- Place these components near SQ33020:
  - Fault capacitor, comp capacitor,  $f_{MAX}$  resistor, CS resistor (in series), VCC capacitor.
  - ZCS pullup resistor should be placed near the AUX pin of the transformer, and pulldown resistor should be near the ZCS pin.
- The REG and TZ resistors,  $V_{DD}$  and  $V_{IN}$  capacitors should be close to SQ33239.
- GND routing is as follows:
  - SQ33020's GND should be connected to RCS\_GND in order to get accurate  $V_{CS}$  signal.

- Because  $V_{GS(TH)}$  of the MOS FET may be as low as 1.2V, it can easily be falsely triggered by noise.
  - Connect IC\_GND to RCS\_GND directly.
- Keep the drive loop as small as possible.

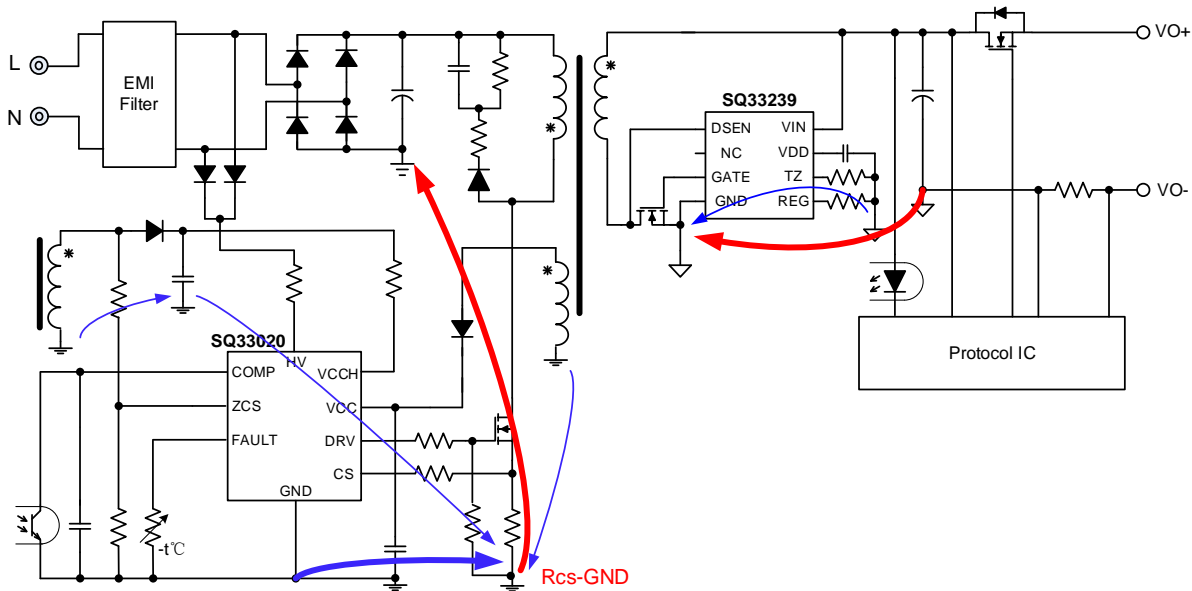

Figure 20. Recommended PCB Layout

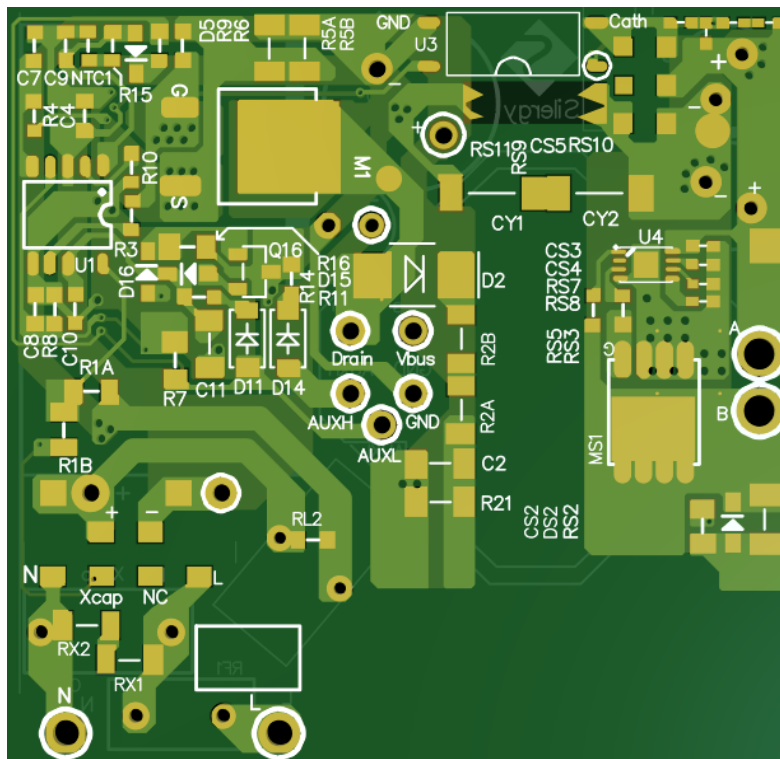

Figure 21. Recommended PCB Layout (Bottom Layer)

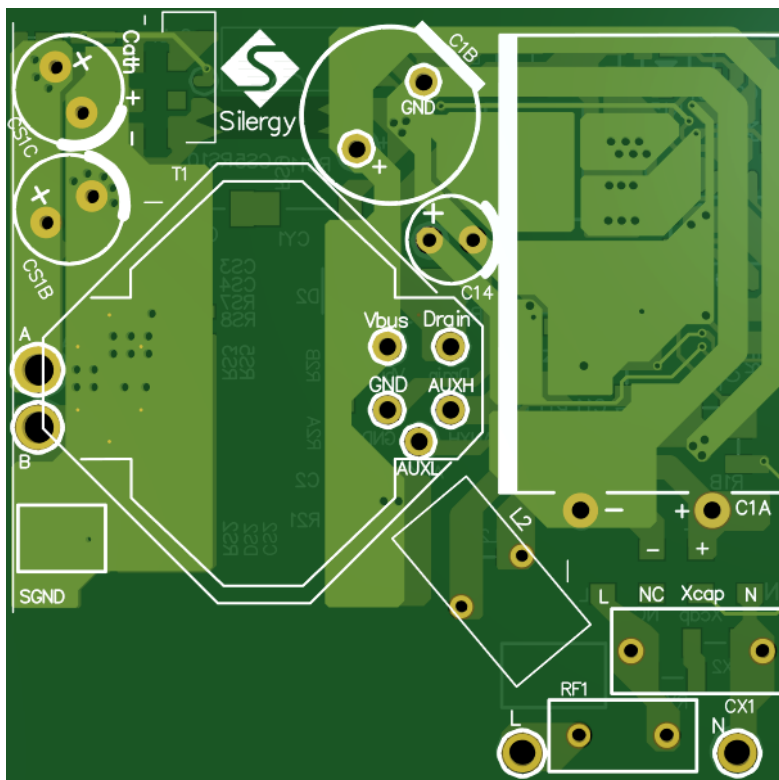

Figure 22. Recommended PCB Layout (Top Layer)

## Design Example

This section provides a step-by-step design example of a typical application.

### Input/Output Specifications

Parameter	Symbol	Value
Input voltage range	$V_{IN}$	DC200V–DC400V (with PFC)
Rated output power	$P_o$	66W
Rated output voltage	$V_o$	5V–20V
Output OVP level	$V_{O\_ovp}$	24V
Rated output current	$I_o$	3.3A
Output OCP	$I_{ocp}$	3.7A
Efficiency	$\eta$	93%

### Preset Parameters

Parameter	Symbol	Value
Breakdown voltage of power MOS	$V_{MOS\_BR}$	700V
$V_{DS}$ de-rating factor of power MOS	$K_{DR}$	90%
Spike on $V_{DS}$ at power MOS turn-off	$\Delta V_{SN}$	70V
BUS capacitor charge coefficient	$K_{CH}$	0.2
Secondary diode forward voltage drop	$V_{D\_R}$	0V (SR)
Transformer effective $A_e$ (RM8)	$A_E$	62mm <sup>2</sup>

#### 1. BUS capacitor selection

Select BUS capacitor:  $C_{BUS} = 33\mu F$  (0.5uF/W with PFC)

#### 2. Minimum BUS voltage

$V_{BUS\_MIN} = 200V$  (With PFC)

**3. Transformer design**

(a) Transformer core: RM8,  $A_e = 62\text{mm}^2$

(b) Winding width of bobbin: 8.1mm

(c)  $N_s$  winding wire: 0.10mm × 100

(d)  $N_s = 5\text{ts}$

(e)  $N_{PS}$  is selected as:  $N_{PS} = 6.25$ , reflected voltage  $V_{OR} = 6.25 \times 20\text{V} = 125\text{V}$

(f)  $N_p$  is calculated as  $N_p = N_{PS} \times N_s = 31\text{ts}$

(g)  $N_p$  winding wire: 8.1mm × 90%/16ts; wire should be 0.45mm–0.02mm = 0.43mm, or Litz line of 0.10mm × 20

(h) Calculate  $R_{CS}$ : in normal operation,  $V_{REF\_OCP} = 0.85\text{V}$

$$R_{CS} = \frac{0.93 \times V_{REF\_OCP} \times N_{PS}}{6 \times I_{OUT\_OCP}} = \frac{0.93 \times 0.85\text{V} \times 6.25}{6 \times 3.7\text{A}} = 0.222\Omega$$

(i) Calculate maximum primary peak current:

$$I_{PPK\_MAX} = \frac{V_{CS\_LIMIT}}{R_{CS}} = \frac{0.50\text{V}}{0.222\Omega} = 2.25\text{A}$$

(j) Determine  $B_{MAX} = 0.37\text{T}$

(k) Calculate primary winding  $L_p$ :

$$N_p = \frac{L_p \times I_{PPK\_MAX}}{B_{MAX} \times A_e} = \frac{L_p \times 2.25\text{A}}{0.37\text{T} \times 62\text{mm}^2} = 31\text{ts}, \text{ then } L_p = 316\mu\text{H}.$$

(l) Calculate auxiliary winding turns  $N_{AUXL} = 5\text{ts}$ :  $V_{OUT\_MAX} = 20\text{V}$

$$18\text{V} < \frac{V_{OUT\_MAX}}{N_s} \times N_{AUXL} < 22\text{V}, \quad 4.5 < N_{AUXL} < 5.5$$

(m) Calculate auxiliary winding turns  $N_{AUXH} = 12\text{ts}$ :  $V_{OUT\_MIN} = 5\text{V}$

$$10\text{V} < \frac{V_{OUT\_MIN}}{N_s} \times N_{AUXL} < 14\text{V}, \quad 10 < N_{AUXH} < 14$$

**4. Secondary diode selection**

(a) Maximum reverse voltage calculation:

$$V_{D\_R\_MAX} = \frac{\sqrt{2} V_{IN\_MAX}}{N_{PS}} + V_{O\_OVP} = \frac{\sqrt{2} \times 264}{6.25} + 24 = 84\text{V}$$

Considering the voltage spike, reverse voltage rating is recommended to be 100V–120V.

(b) Maximum instantaneous forward current:

$$I_{SPK\_MAX} = I_{PPK\_MAX} \times N_{PS} = 2.25\text{A} \times 6.25 = 14.1\text{A}$$

### SSOP9 Package Outline Drawing

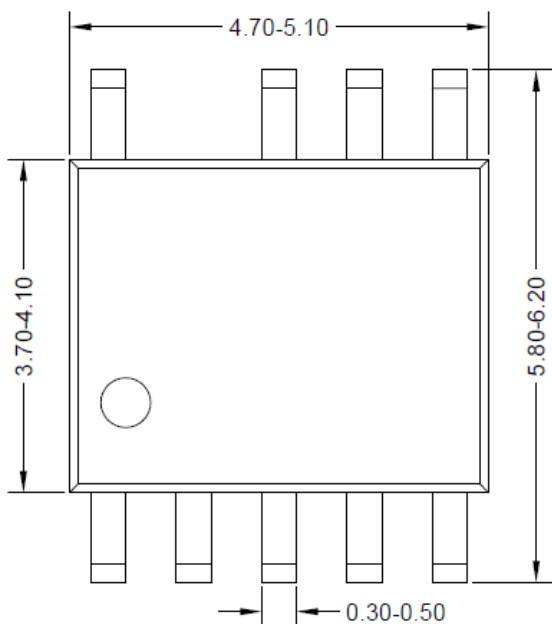

Top View

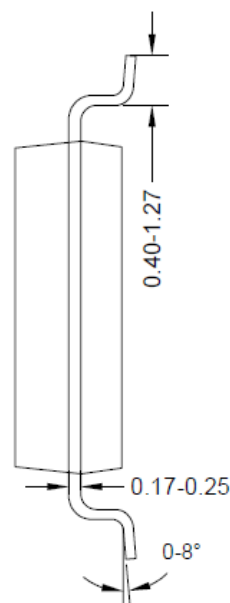

Side View

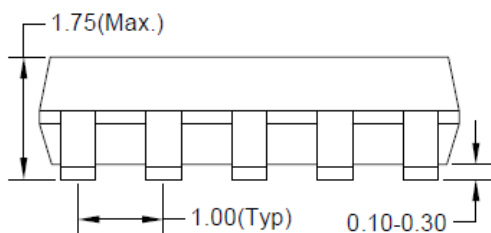

Front View

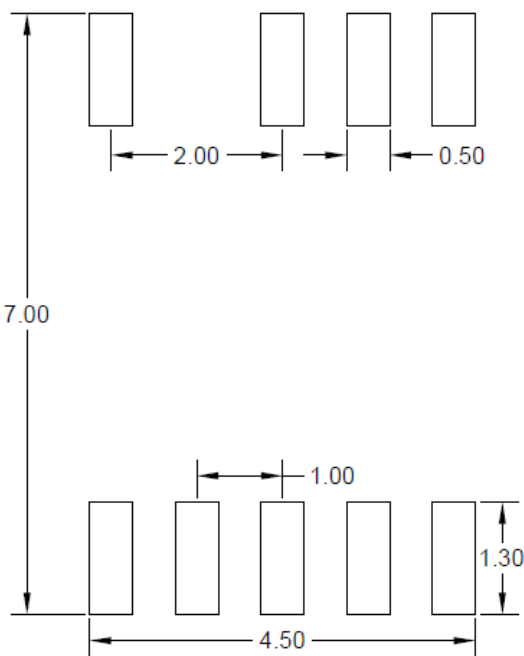

Recommended PCB Layout  
(Reference Only)

**Note:** All dimensions are in millimeters and exclude mold flash and metal burr.

## Tape and Reel Specification

### Tape dimensions and pin 1 orientation

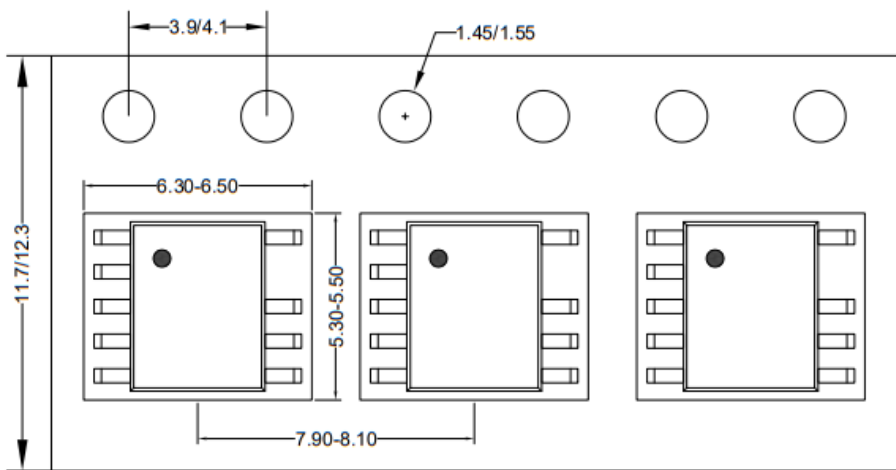

Feeding Direction →

### Reel dimensions

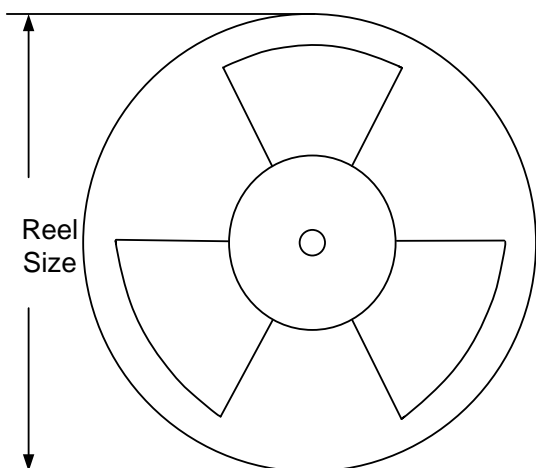

Package types	Tape width (mm)	Pocket pitch (mm)	Reel size (Inch)	Trailer * length (mm)	Leader * length (mm)	Qty per reel (pcs)
SSOP9	12	8	13"	400	400	4000

## Revision History

The revision history provided is for informational purposes only and is believed to be accurate, however, not warranted. Please make sure that you have the latest revision.

<b>Date</b>	<b>Revision</b>	<b>Change</b>
June 9,2024	Revision 1.0	Initial Release

**IMPORTANT NOTICE**

1. **Right to make changes.** Silergy and its subsidiaries (hereafter Silergy) reserve the right to change any information published in this document, including but not limited to circuitry, specification and/or product design, manufacturing or descriptions, at any time and without notice. This document supersedes and replaces all information supplied prior to the publication hereof. Buyers should obtain the latest relevant information before placing orders and should verify that such information is current and complete. All semiconductor products are sold subject to Silergy's standard terms and conditions of sale.

2. **Applications.** Application examples that are described herein for any of these products are for illustrative purposes only. Silergy makes no representation or warranty that such applications will be suitable for the specified use without further testing or modification. Buyers are responsible for the design and operation of their applications and products using Silergy products. Silergy or its subsidiaries assume no liability for any application assistance or designs of customer products. It is customer's sole responsibility to determine whether the Silergy product is suitable and fit for the customer's applications and products planned. To minimize the risks associated with customer's products and applications, customer should provide adequate design and operating safeguards. Customer represents and agrees that it has all the necessary expertise to create and implement safeguards which anticipate dangerous consequences of failures, monitor failures and their consequences, lessen the likelihood of failures that might cause harm and take appropriate remedial actions. Silergy assumes no liability related to any default, damage, costs or problem in the customer's applications or products, or the application or use by customer's third-party buyers. Customer will fully indemnify Silergy, its subsidiaries, and their representatives against any damages arising out of the use of any Silergy components in safety-critical applications. It is also buyers' sole responsibility to warrant and guarantee that any intellectual property rights of a third party are not infringed upon when integrating Silergy products into any application. Silergy assumes no responsibility for any said applications or for any use of any circuitry other than circuitry entirely embodied in a Silergy product.

3. **Limited warranty and liability.** Information furnished by Silergy in this document is believed to be accurate and reliable. However, Silergy makes no representation or warranty, expressed or implied, as to the accuracy or completeness of such information and shall have no liability for the consequences of use of such information. In no event shall Silergy be liable for any indirect, incidental, punitive, special or consequential damages, including but not limited to lost profits, lost savings, business interruption, costs related to the removal or replacement of any products or rework charges, whether or not such damages are based on tort or negligence, warranty, breach of contract or any other legal theory. Notwithstanding any damages that customer might incur for any reason whatsoever, Silergy's aggregate and cumulative liability towards customer for the products described herein shall be limited in accordance with the Standard Terms and Conditions of Sale of Silergy.

4. **Suitability for use.** Customer acknowledges and agrees that it is solely responsible for compliance with all legal, regulatory and safety-related requirements concerning its products, and any use of Silergy components in its applications, notwithstanding any applications-related information or support that may be provided by Silergy. Silergy products are not designed, authorized or warranted to be suitable for use in life support, life-critical or safety-critical systems or equipment, nor in applications where failure or malfunction of an Silergy product can reasonably be expected to result in personal injury, death or severe property or environmental damage. Silergy assumes no liability for inclusion and/or use of Silergy products in such equipment or applications and therefore such inclusion and/or use is at the customer's own risk.

5. **Terms and conditions of commercial sale.** Silergy products are sold subject to the standard terms and conditions of commercial sale, as published at <http://www.silergy.com/stdterms>, unless otherwise agreed in a valid written individual agreement specifically agreed to in writing by an authorized officer of Silergy. In case an individual agreement is concluded only the terms and conditions of the respective agreement shall apply. Silergy hereby expressly objects to and denies the application of any customer's general terms and conditions with regard to the purchase of Silergy products by the customer.

6. **No offer to sell or license.** Nothing in this document may be interpreted or construed as an offer to sell products that is open for acceptance or the grant, conveyance or implication of any license under any copyrights, patents or other industrial or intellectual property rights. Silergy makes no representation or warranty that any license, either express or implied, is granted under any patent right, copyright, mask work right, or other intellectual property right. Information published by Silergy regarding third-party products or services does not constitute a license to use such products or services or a warranty or endorsement thereof. Use of such information may require a license from a third party under the patents or other intellectual property of the third party, or a license from Silergy under the patents or other intellectual property of Silergy.

For more information, please visit: [www.silergy.com](http://www.silergy.com)

©2024 Silergy Corp.

All Rights Reserved.