



SILERGY

SY86011B

5.5V 10A Load Switch with Ultra Low $R_{DS(ON)}$

General Description

The SY86011B is a 5.3m Ω , single-channel load switch with an N-channel MOSFET that can operate over an input voltage range from 0.285V to 5.5V and can support a maximum continuous current of 10A. The wide input voltage range and high current capability enable the device to be used across multiple designs and end equipment. 5.3m Ω ON resistance minimizes the voltage drop across the load switch and power loss from the load switch.

The controlled rise time for the device greatly reduces inrush current caused by large bulk load capacitances, thereby reducing or eliminating power supply droop.

The SY86011B has an optional 50 Ω discharge resistor for quick discharge of the output when switch is disabled to avoid any unknown state caused by floating supply to the downstream load.

The SY86011B is available in a small, space-saving QFN1.5 \times 2 package. The device is characterized for operation over the free-air temperature range of -40 $^{\circ}$ C to +105 $^{\circ}$ C.

Features

- Integrated Single Channel Load Switch
- V_{BIAS} Voltage Range: 2.2V to 5.5V
- V_{IN} Voltage Range: 0.285V to V_{BIAS}
- On-Resistance
 - $R_{ON} = 5.3m\Omega$ (typical) at $V_{IN}=5V$ ($V_{BIAS}=5V$)
 - $R_{ON} = 5.3m\Omega$ (typical) at $V_{IN}=3.3V$ ($V_{BIAS}=3.3V$)
- 10A Maximum Continuous Switch Current
- Auto Output Discharge: 50 Ω
- RoHS Compliant and Halogen Free
- Compact Package: QFN1.5 \times 2-10

Applications

- Notebooks
- Desktop PC
- SSDs
- Servers
- Telecom Systems

Typical Application

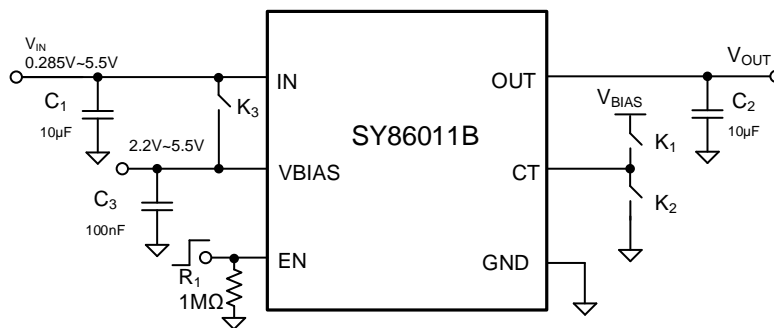

Figure 1. Schematic Diagram

Ordering Information

Ordering Part Number	Package Type	Top Mark
SY86011BWPQ	QFN1.5×2-10 RoHS Compliant and Halogen Free	KLRxyz

Device code: KLR

x = year code, y = week code, z = lot number code

Pinout (top view)

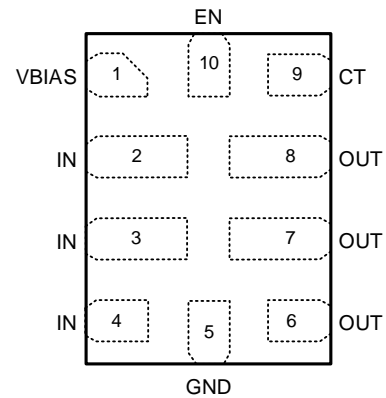

Pin Name	Pin Number	Pin Description
VBIAS	1	Bias pin. Bias supply for overdriving the gate of the pass switch between input and output. The recommended BIAS voltage range is 2.2V to 5.5V.
IN	2,3,4	Switch input. Decouple this pin to GND with at least a 10μF ceramic capacitor.
GND	5	Ground pin.
OUT	6,7,8	Switch output. Decouple this pin to GND with at least a 10μF ceramic capacitor.
CT	9	Soft start programmable pin, Tri-state Selection for Soft start time without external capacitor. The pull-high and pull-low resistor should be less than 50kΩ.
EN	10	Enable interface pin. Active high switch control input. Do not leave it floating.

Block Diagram

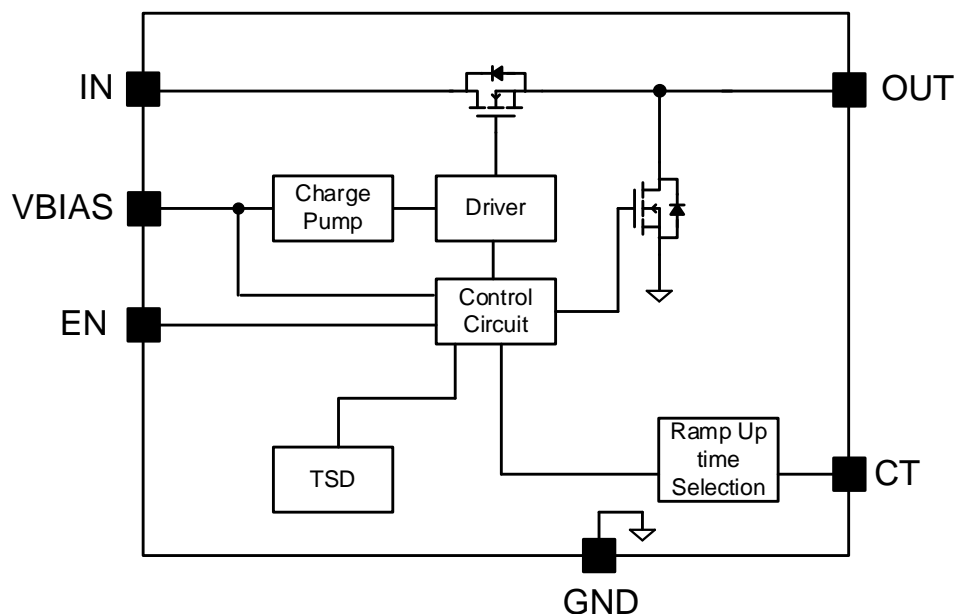

Figure2. Block Diagram



Absolute Maximum Ratings

Parameter (Note 1)	Min	Max	Unit
IN, VBIAS, OUT, EN	-0.3	6	V
CT	-0.3	V _{BIAS} +0.3	
Lead Temperature (Soldering, 10s)		260	°C
Junction Temperature, Operating	-40	150	
Storage Temperature	-65	150	

Thermal Information

Parameter (Note 2)	Typ	Unit
θ_{JA} Junction-to-Ambient Thermal Resistance	54.5	°C/W
θ_{JC} Junction-to-Case Thermal Resistance	21.5	
P _D Power Dissipation TA = 25°C	1.83	W

Recommended Operating Conditions

Parameter (Note 3)	Min	Max	Unit
IN	0.285	V _{BIAS}	V
VBAIS	2.2	5.5	
CT	0	V _{BIAS}	
OUT	0	V _{IN}	
EN	0	5.5	
Junction Temperature, Operating	-40	125	°C
Ambient Temperature	-40	105	

Electrical Characteristics

(Unless otherwise noted, the specification in the following table applies over the operating ambient temp - 40°C ≤ T_A ≤ +105°C and V_{BIAS} = 5V. Typical values are for T_A = 25°C, unless otherwise noted. (Note 4))

Parameter	Symbol	Test Conditions	Min	Typ	Max	Unit
Voltage range for V _{IN}	V _{IN}		0.285		5.5	V
Voltage range for V _{BIAS}	V _{BIAS}		2.2		5.5	V
V _{BIAS} UVLO	V _{BIAS_UVLO}				2.1	V
V _{BIAS} UVLO Hysteresis	V _{BIAS_HYS}			0.1		V
V _{BIAS} Quiescent Current	I _{Q_BIAS}	V _{BIAS} =5V, V _{IN} =V _{EN} =5V		40	60	μA
		V _{BIAS} =3.3V, V _{IN} =V _{EN} =3.3V		30	60	μA
V _{BIAS} Shutdown Current	I _{SHDN_BIAS}	V _{BIAS} =5V, V _{IN} =5V, V _{EN} =0V		1	5	μA
		V _{BIAS} =3.3V, V _{IN} =3.3V, V _{EN} =0V		1	5	μA
EN Leakage Current	I _{EN_LKG}	V _{EN} =5.5V			0.1	μA
EN Turn-on Threshold	V _{EN_ON}	V _{BIAS} =3.3V, V _{IN} =3.3V	0.84	0.9	0.96	V
EN Turn on Threshold Hysteresis	V _{EN_HYS}	V _{BIAS} =3.3V, V _{IN} =3.3V		0.2		V
EN Input Low Level Voltage	V _{EN_OFF}	T _A =25°C			0.2	V
Integrate FET RON	R _{DS(ON)}	V _{BIAS} =V _{EN} =5V, I _{OUT} =1A V _{IN} =2.5V		5.3	7	mΩ
		V _{BIAS} =V _{EN} =5V, I _{OUT} =1A V _{IN} =1.8V		5.3	7	mΩ
		V _{BIAS} =V _{EN} =5V, I _{OUT} =1A V _{IN} =1.1V		5.3	7	mΩ
		V _{BIAS} =V _{EN} =5V, I _{OUT} =1A V _{IN} =0.55V		5.3	7	mΩ

Parameter	Symbol	Test Conditions	Min	Typ	Max	Unit
Output Discharge Resistance	R _{D_{DSG}}	V _{BIAS} =V _{IN} =3.3V, V _{EN} =0, V _{OUT} =0.1V I _{OUT} = 0A		50		Ω
		V _{BIAS} =V _{IN} =5V, V _{EN} =0, V _{OUT} =0.1V I _{OUT} = 0A		50		Ω
EN ON Delay Time	t _{d_ON}	R _L =10Ω, C _L =0.1μF, V _{BIAS} =V _{IN} =3.3V, V _{EN} =0V to 3.3V	20	35	50	μs
EN OFF Delay Time	t _{d_OFF}	R _L =10Ω, C _L =0.1μF, V _{BIAS} =V _{IN} =3.3V, V _{EN} =3.3V to 0V,	2	5	8	μs
V _{OUT} Rise Slew Rate	SR	R _L =10Ω, C _L =4.7μF, V _{BIAS} =V _{IN} =3.3V, V _{EN} =0V to 3.3V, CT Floating	13.34	16.67	20	V/ms
		R _L =10Ω, C _L =4.7μF, V _{BIAS} =V _{IN} =3.3V, V _{EN} =0V to 3.3V, CT Pull up	1.6	2	2.4	V/ms
		R _L =10Ω, C _L =4.7μF, V _{BIAS} =V _{IN} =3.3V, V _{EN} =0V to 3.3V, CT Pull low	0.8	1	1.2	V/ms
V _{OUT} Fall Time	t _{fall}	R _L =10Ω, C _L =4.7μF, V _{BIAS} =V _{IN} =3.3V, V _{EN} =3.3V to 0V, CT Pull up		117		μs
		R _L =10Ω, C _L =4.7μF, V _{BIAS} =V _{IN} =3.3V, V _{EN} =3.3V to 0V, CT Floating		117		μs
		R _L =10Ω, C _L =4.7μF, V _{BIAS} =V _{IN} =3.3V, V _{EN} =3.3V to 0V, CT Pull low		117		μs
Thermal Shutdown Temperature	T _{SD}			150		°C
Thermal Shutdown Hysteresis	T _{HYS}			20		°C

Note 1: Stresses beyond the “Absolute Maximum Ratings” may cause permanent damage to the device. These are stress ratings only. Functional operation of the device at these or any other conditions beyond those indicated in the operational sections of the specification is not implied. Exposure to absolute maximum rating conditions for extended periods may affect device reliability

Note 2: θ_{JA} is simulated in the natural convection at T_A=25°C on a Silergy evaluation board following JEDEC51-2 thermal measurement standard.

Note 3: The device is not guaranteed to function outside its operating conditions.

Note 4: Unless otherwise stated, limits are 100% production tested under pulsed load conditions such that T_A ≅ T_J= 25°C. Limits over the operating temperature range (see recommended operating conditions) and relevant voltage range(s) are guaranteed by design, test, or statistical correlation.



Soft Start Time Program

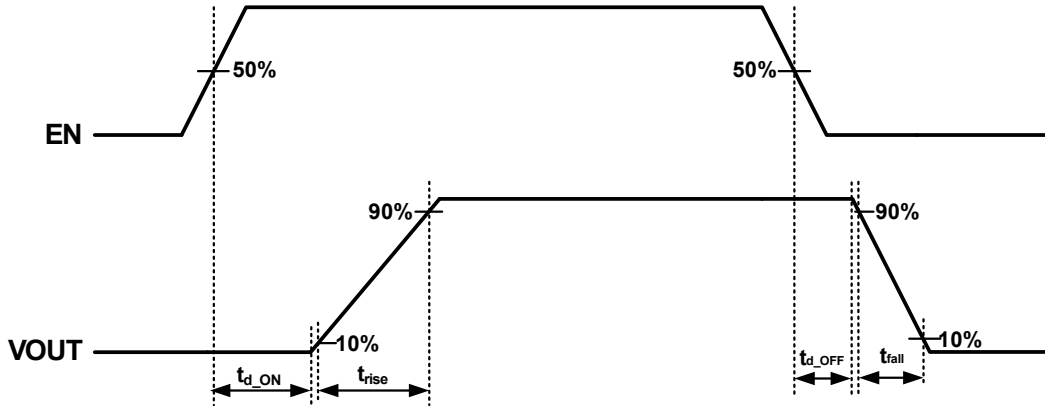
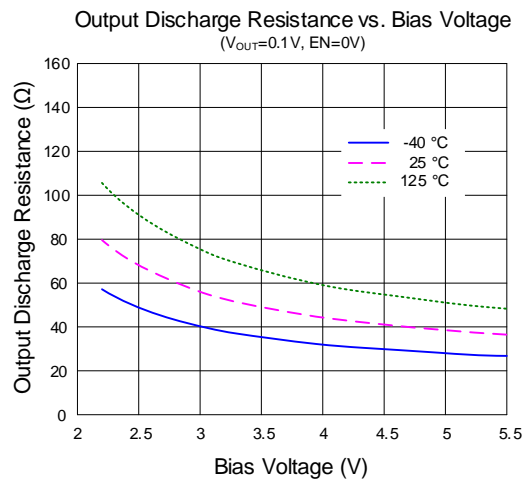
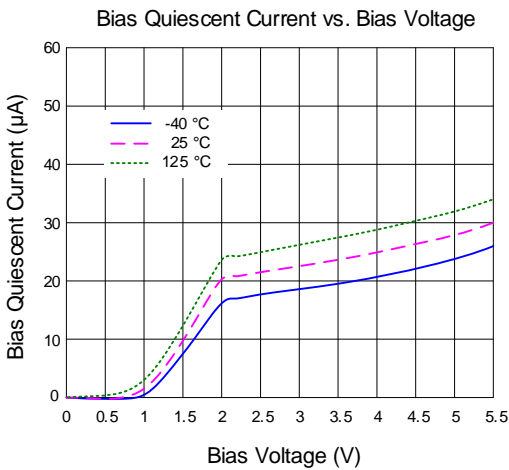
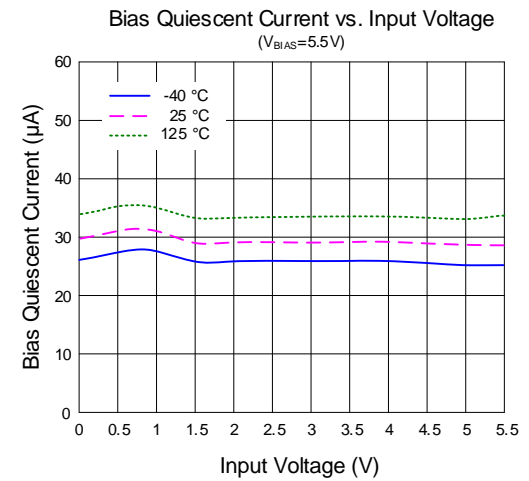
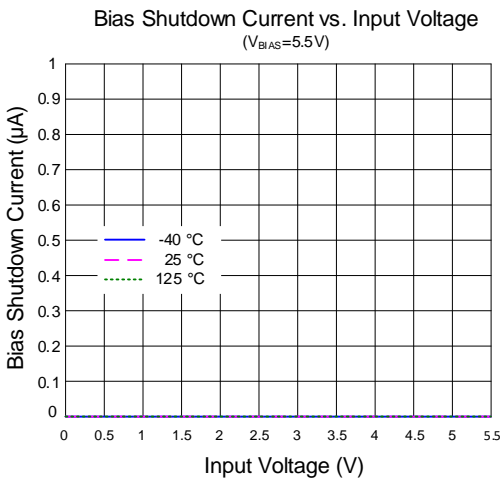
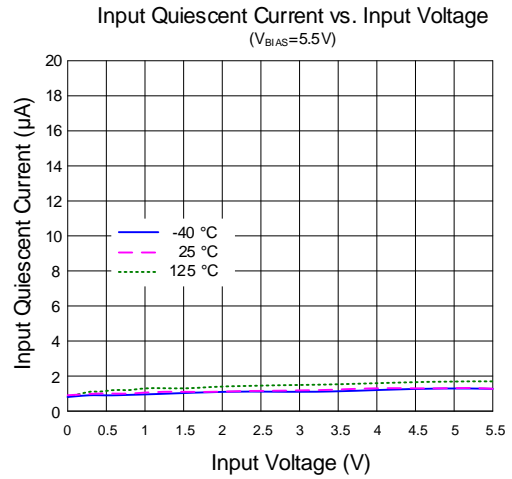
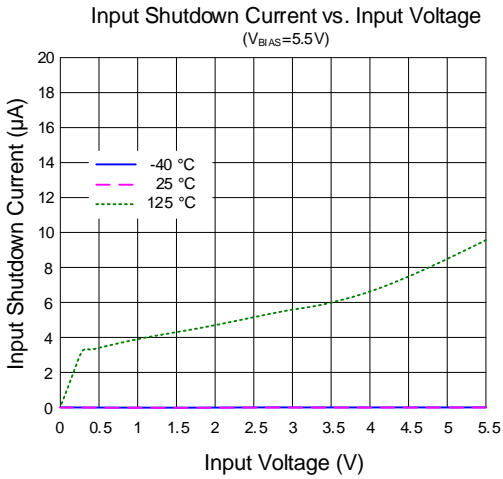
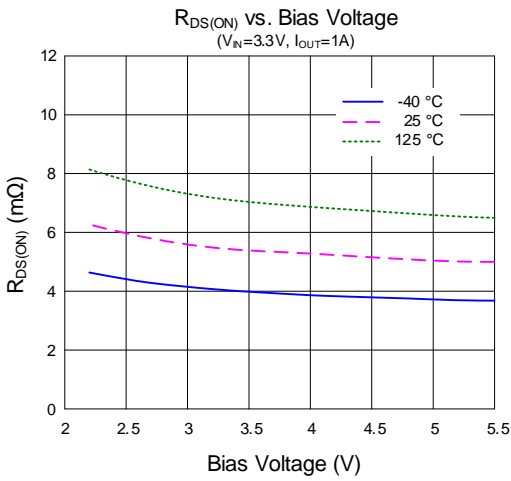
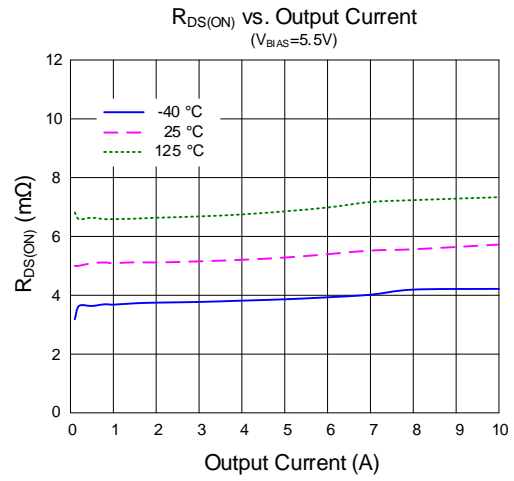
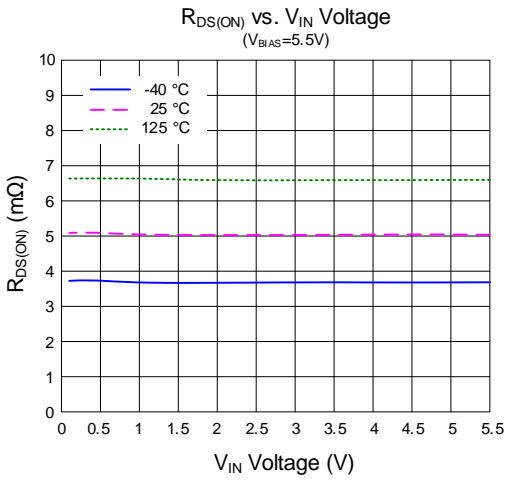

Figure 3. Soft Start Time

Typical Performance Characteristics







Typical Performance Characteristics

EN ON
($V_{BIAS}=V_{IN}=5V$, $C_N=10\mu F$, $C_{OUT}=4.7\mu F$, CT Floating, Null load)

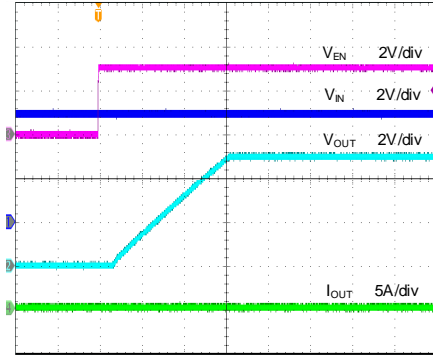

Time (100µs/div)

EN OFF
($V_{BIAS}=V_{IN}=5V$, $C_N=10\mu F$, $C_{OUT}=4.7\mu F$, CT Floating, Null load)

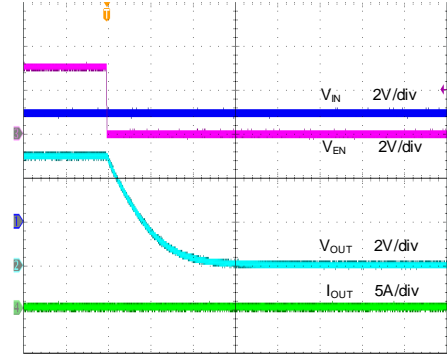

Time (400µs/div)

EN ON
($V_{BIAS}=V_{IN}=5V$, $C_N=10\mu F$, $C_{OUT}=4.7\mu F$, CT High, Null load)

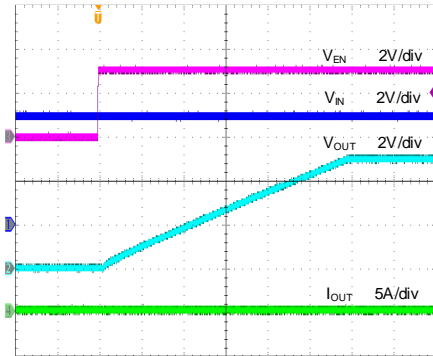

Time (400µs/div)

EN OFF
($V_{BIAS}=V_{IN}=5V$, $C_N=10\mu F$, $C_{OUT}=4.7\mu F$, CT High, Null load)

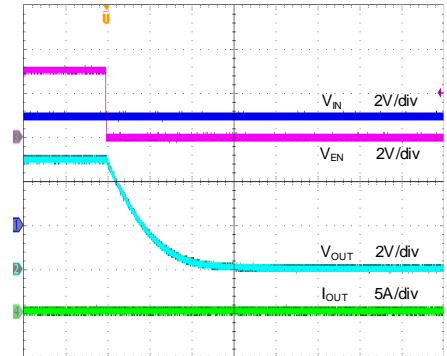

Time (400µs/div)

EN ON
($V_{BIAS}=V_{IN}=5V$, $C_N=10\mu F$, $C_{OUT}=4.7\mu F$, CT Low, Null load)

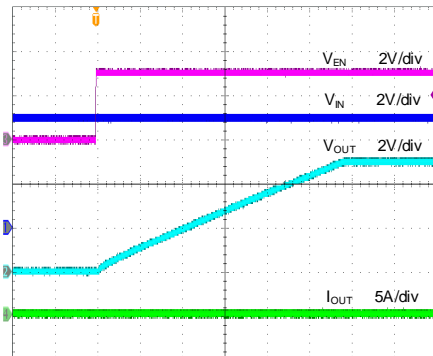

Time (800µs/div)

EN OFF
($V_{BIAS}=V_{IN}=5V$, $C_N=10\mu F$, $C_{OUT}=4.7\mu F$, CT Low, Null load)

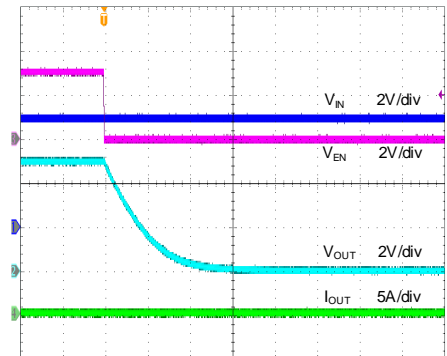

Time (400µs/div)

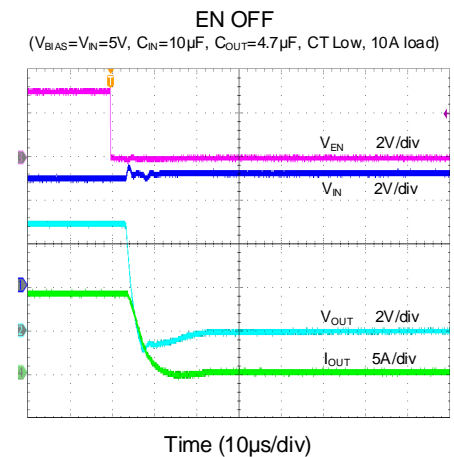
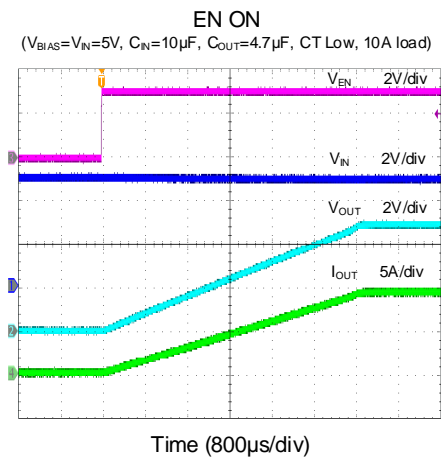
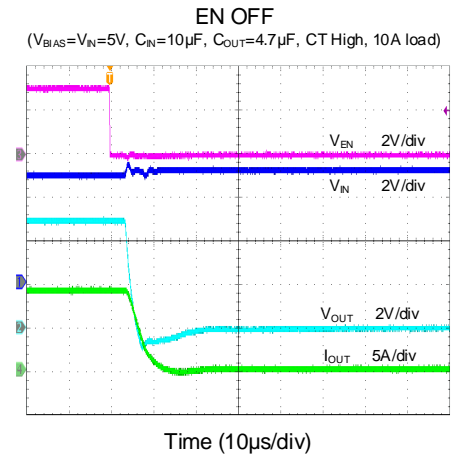
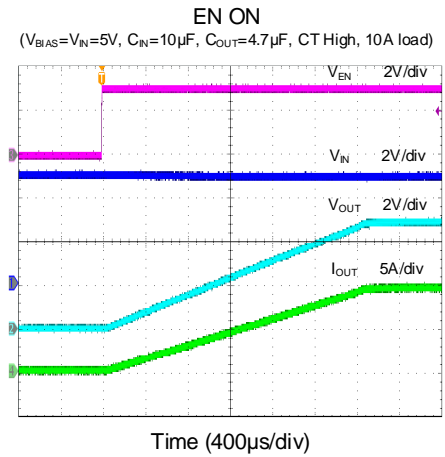
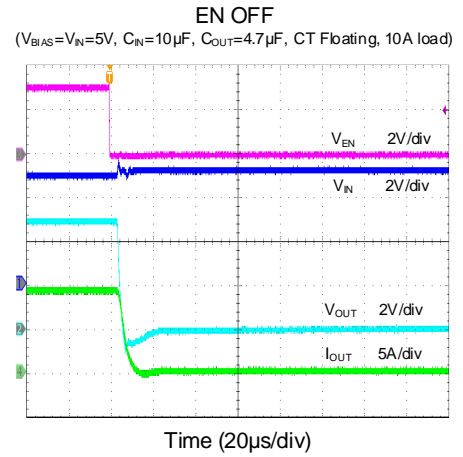
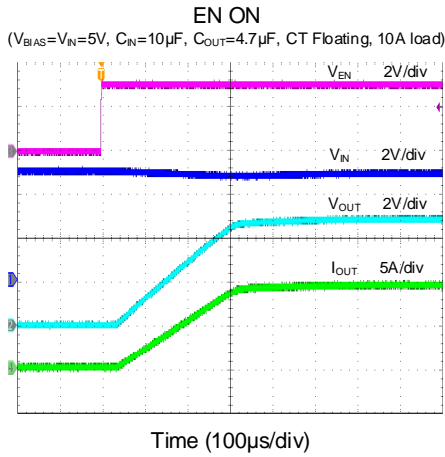

V_{BIAS} & V_{IN} ON
 (V_{BIAS}=V_{IN}=5V, C_{IN}=10μF, C_{OUT}=4.7μF, CT Floating, Null load)

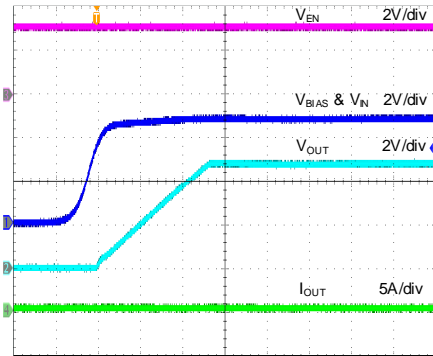

Time (100μs/div)

V_{BIAS} & V_{IN} OFF
 (V_{BIAS}=V_{IN}=5V, C_{IN}=10μF, C_{OUT}=4.7μF, CT Floating, Null load)

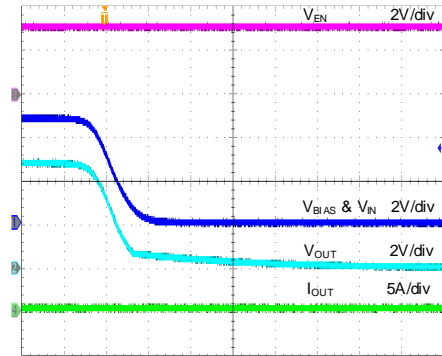

Time (100μs/div)

V_{BIAS} & V_{IN} ON
 (V_{BIAS}=V_{IN}=5V, C_{IN}=10μF, C_{OUT}=4.7μF, CT High, Null load)

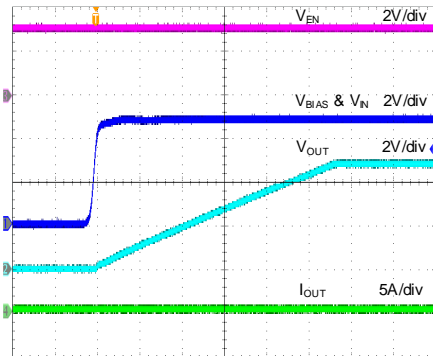

Time (400μs/div)

V_{BIAS} & V_{IN} OFF
 (V_{BIAS}=V_{IN}=5V, C_{IN}=10μF, C_{OUT}=4.7μF, CT High, Null load)

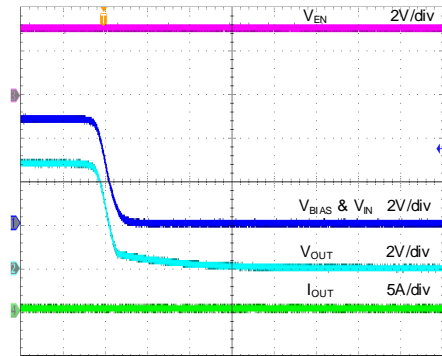

Time (200μs/div)

V_{BIAS} & V_{IN} ON
 (V_{BIAS}=V_{IN}=5V, C_{IN}=10μF, C_{OUT}=4.7μF, CT Low, Null load)

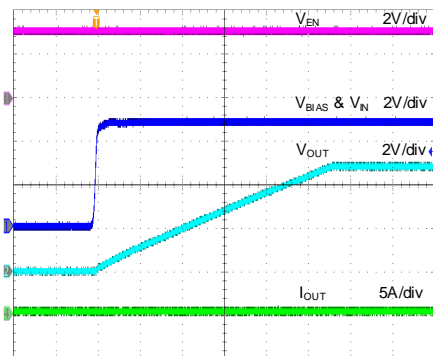

Time (800μs/div)

V_{BIAS} & V_{IN} OFF
 (V_{BIAS}=V_{IN}=5V, C_{IN}=10μF, C_{OUT}=4.7μF, CT Low, Null load)

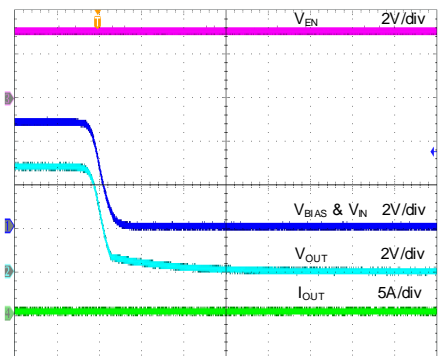

Time (200μs/div)

V_{BIAS} & V_{IN} ON
 (V_{BIAS}=V_{IN}=5V, C_{IN}=10μF, C_{OUT}=4.7μF, CT Floating, 10A load)

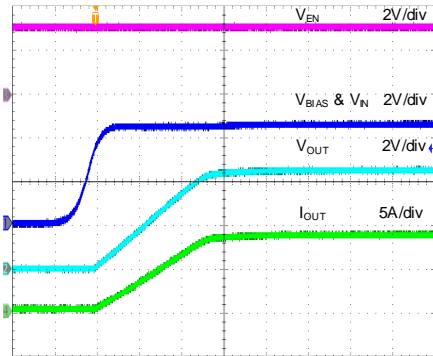

Time (100μs/div)

V_{BIAS} & V_{IN} OFF
 (V_{BIAS}=V_{IN}=5V, C_{IN}=10μF, C_{OUT}=4.7μF, CT Floating, 10A load)

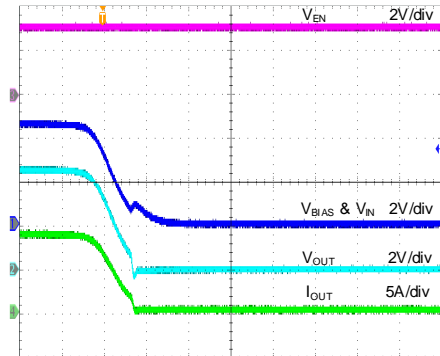

Time (100μs/div)

V_{BIAS} & V_{IN} ON
 (V_{BIAS}=V_{IN}=5V, C_{IN}=10μF, C_{OUT}=4.7μF, CT High, 10A load)

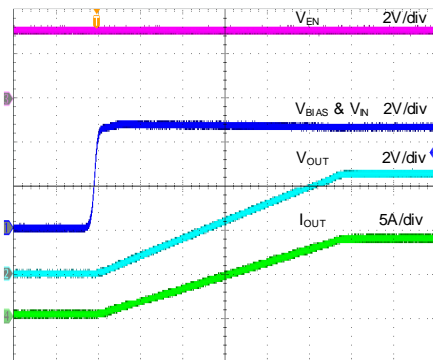

Time (400μs/div)

V_{BIAS} & V_{IN} OFF
 (V_{BIAS}=V_{IN}=5V, C_{IN}=10μF, C_{OUT}=4.7μF, CT High, 10A load)

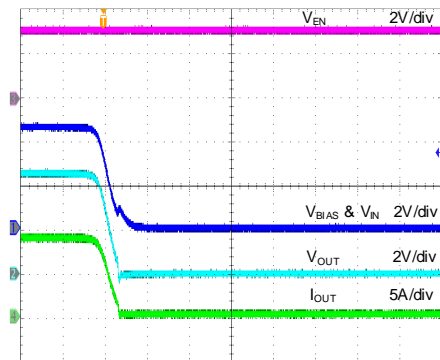

Time (200μs/div)

V_{BIAS} & V_{IN} ON
 (V_{BIAS}=V_{IN}=5V, C_{IN}=10μF, C_{OUT}=4.7μF, CT Low, 10A load)

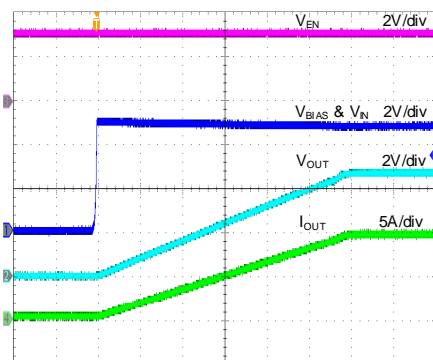

Time (800μs/div)

V_{BIAS} & V_{IN} OFF
 (V_{BIAS}=V_{IN}=5V, C_{IN}=10μF, C_{OUT}=4.7μF, CT Low, 10A load)

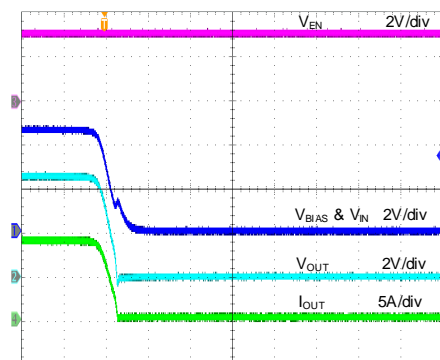

Time (200μs/div)

Operation

The SY86011B is a 5.3mΩ, single-channel load switch with an N-channel MOSFET that can operate over an input voltage range from 0.285V to 5.5V and can support a maximum continuous current of 10A. The wide input voltage range and high current capability enable the device to be used across multiple designs and end equipment. 5.3mΩ ON resistance minimizes the voltage drop across the load switch and power loss from the load switch.

The controlled rise time for the device greatly reduces inrush current caused by large bulk load capacitances, thereby reducing or eliminating power supply droop.

Applications Information

Input Capacitor C_{IN}:

To reduce device inrush current, a 10μF ceramic capacitor, C_{IN}, is recommended. A higher value of C_{IN} can be used for reducing the voltage drop experienced as the switch is turned on into large capacitive load. To minimize the potential noise problem, C_{IN} should be placed really close to the IN and GND pins.

Output Capacitor C_{OUT}:

A 10μF output ceramic capacitor is recommended to be placed close to the IC and output connector to reduce voltage drop during load transient. Higher value of C_{OUT} can be used for further reducing the voltage drop during high current application.

Output Discharge:

The SY86011B integrate a 50Ω pull down resistor for quick output discharge. The resistor is activated when the switch is turned off.

Soft Start Function:

The SY86011B has controlled rise time for inrush current control. Tri-state Selection for soft-start time without external capacitor. The pull-high and pull-low resistor should be less than 50kΩ.

Thermal Considerations:

The SY86011B can deliver a current of up to 10A over the full operating temperature range. However, the maximum output current must be derated at higher ambient temperature. With all possible conditions, the junction temperature must be within the range specified under operating conditions. Power dissipation can be calculated based on the output current and the voltage drop across regulator.

$$P_D = (V_{IN} - V_{OUT}) \times I_{OUT} + V_{IN} \times I_{GND}$$

The final operating junction temperature for any set of condition can be estimated by the following thermal equation:

$$P_{D(MAX)} = (T_{J(MAX)} - T_A) / \theta_{JA}$$

Where T_{J(MAX)} is the maximum junction temperature of die (125 °C) and T_A is the maximum ambient temperature. The junction to ambient thermal resistance (θ_{JA}) footprint is 54.5°C /W for QFN package.



Schematic

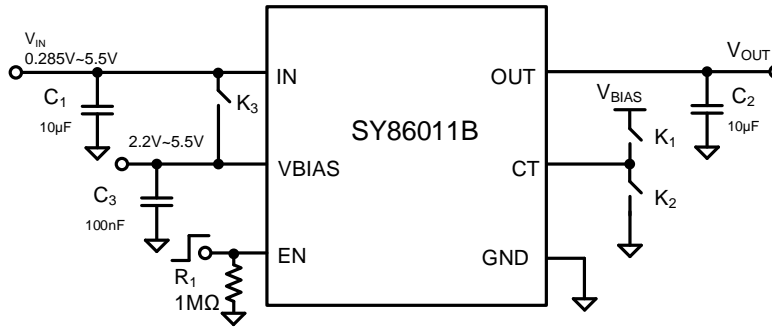

BOM List

Reference Designator	Description	Part Number	Manufacturer
C ₁ , C ₂	10µF/10V, ±10%, X5R, 0805	GRM21BR71A106K	Murata
C ₃	100nF/50V, ±10%, X7R, 0603	GRM188R61H104K	Murata
R ₁	1MΩ, 1%, 0.1W, 0603	RC0603FR-071ML	YAGEO

PCB Layout Guide

For the best performance of the SY86011B, the following guidelines must be strictly followed:

- 1) Keep all Power traces (VIN / OUT / BIAS/ GND) as short and wide as possible and use at least 2-ounce copper for all Power traces.
- 2) Place a ground plane under all circuitry to lower both resistance and inductance and improve DC and transient performance.
- 3) Input and output capacitors should be placed closed to the SY86011B and connected to ground plane to reduce noise coupling.

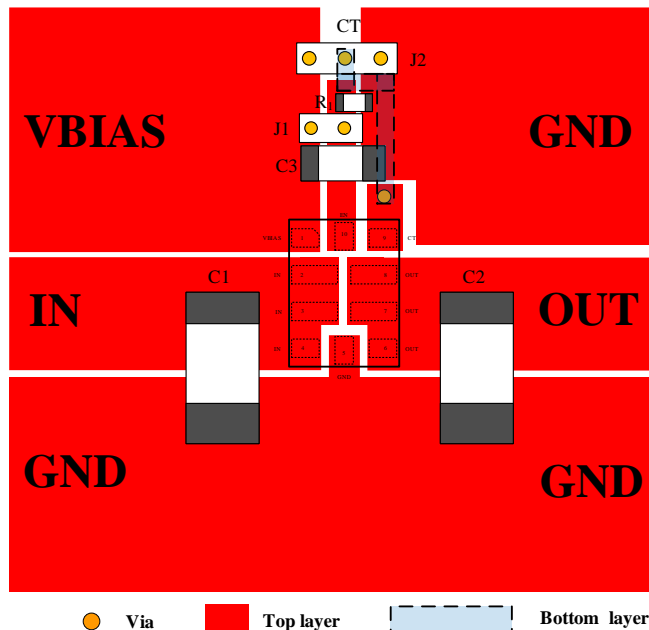
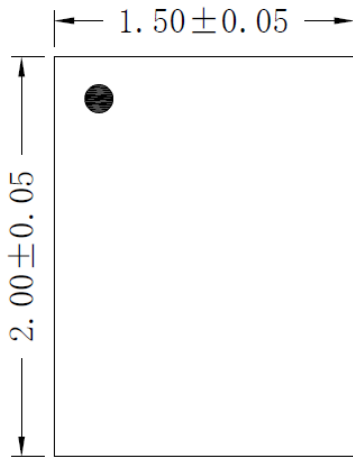
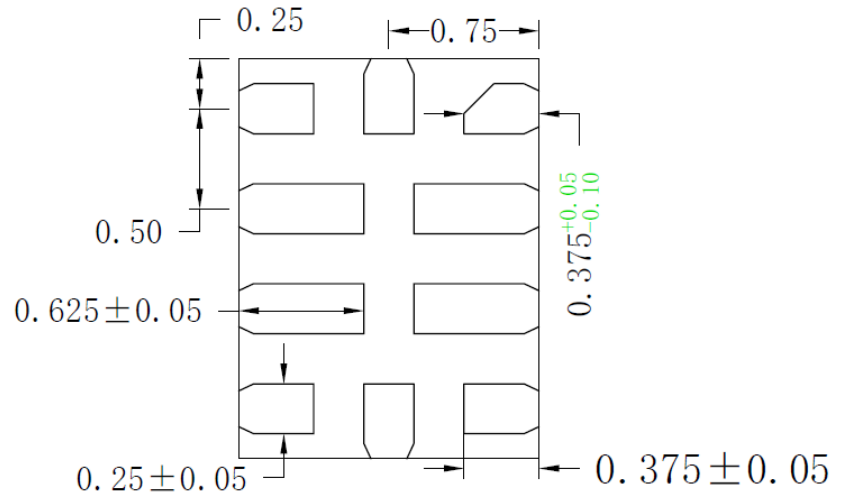

Figure4. PCB Layout Suggestion

QFN1.5x2-10 Package Outline



Top View



Bottom View

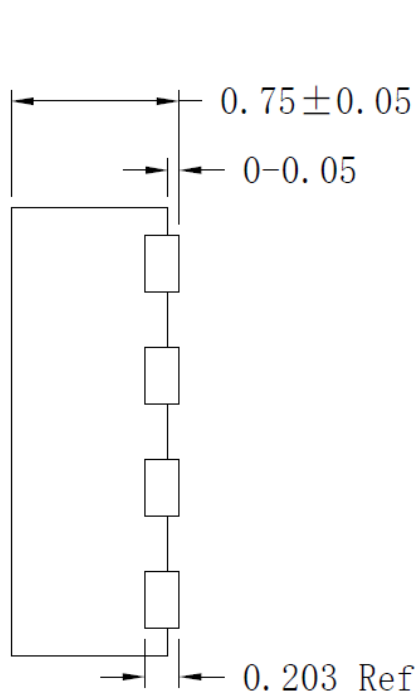

Side View

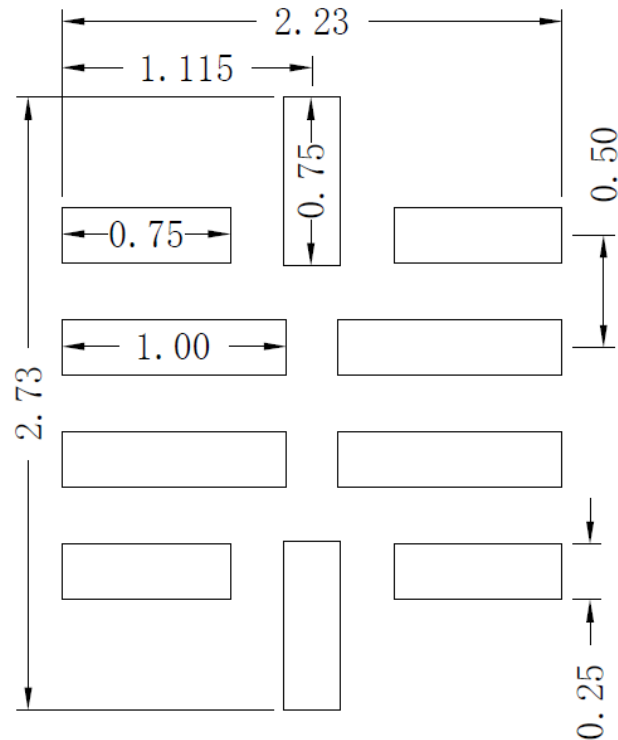

**Recommended PCB Layout
(Reference only)**

Notes: All dimension in millimeter and exclude mold flash & metal burr.

Tape and Reel Information

1. Tape dimensions and Pin1 orientation

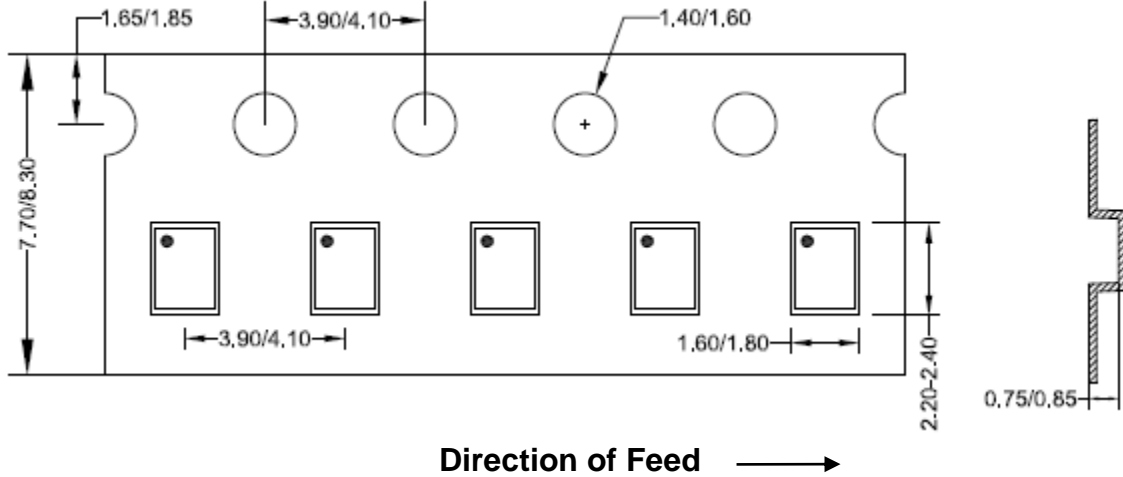

2. Reel dimensions

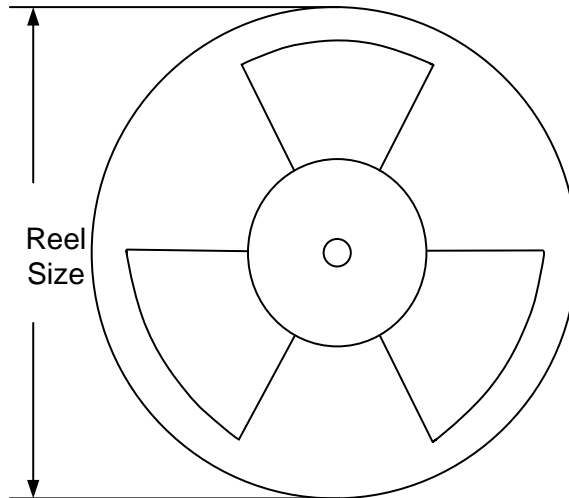

Package types	Tape width (mm)	Pocket pitch(mm)	Reel size (Inch)	Trailer length(mm)	Leader length (mm)	Qty per reel
QFN1.5×2	8	4	7	400	160	3000



Revision History

The revision history provided is for informational purpose only and is believed to be accurate, however, not warranted. Please make sure that you have the latest revision.

Date	Revision	Change
Nov. 20, 2024	Revision 1.0	Initial Release

IMPORTANT NOTICE

1. **Right to make changes.** Silergy and its subsidiaries (hereafter Silergy) reserve the right to change any information published in this document, including but not limited to circuitry, specification and/or product design, manufacturing or descriptions, at any time and without notice. This document supersedes and replaces all information supplied prior to the publication hereof. Buyers should obtain the latest relevant information before placing orders and should verify that such information is current and complete. All semiconductor products are sold subject to Silergy's standard terms and conditions of sale.

2. **Applications.** Application examples that are described herein for any of these products are for illustrative purposes only. Silergy makes no representation or warranty that such applications will be suitable for the specified use without further testing or modification. Buyers are responsible for the design and operation of their applications and products using Silergy products. Silergy or its subsidiaries assume no liability for any application assistance or designs of customer products. It is customer's sole responsibility to determine whether the Silergy product is suitable and fit for the customer's applications and products planned. To minimize the risks associated with customer's products and applications, customer should provide adequate design and operating safeguards. Customer represents and agrees that it has all the necessary expertise to create and implement safeguards which anticipate dangerous consequences of failures, monitor failures and their consequences, lessen the likelihood of failures that might cause harm and take appropriate remedial actions. Silergy assumes no liability related to any default, damage, costs or problem in the customer's applications or products, or the application or use by customer's third-party buyers. Customer will fully indemnify Silergy, its subsidiaries, and their representatives against any damages arising out of the use of any Silergy components in safety-critical applications. It is also buyers' sole responsibility to warrant and guarantee that any intellectual property rights of a third party are not infringed upon when integrating Silergy products into any application. Silergy assumes no responsibility for any said applications or for any use of any circuitry other than circuitry entirely embodied in a Silergy product.

3. **Limited warranty and liability.** Information furnished by Silergy in this document is believed to be accurate and reliable. However, Silergy makes no representation or warranty, expressed or implied, as to the accuracy or completeness of such information and shall have no liability for the consequences of use of such information. In no event shall Silergy be liable for any indirect, incidental, punitive, special or consequential damages, including but not limited to lost profits, lost savings, business interruption, costs related to the removal or replacement of any products or rework charges, whether or not such damages are based on tort or negligence, warranty, breach of contract or any other legal theory. Notwithstanding any damages that customer might incur for any reason whatsoever, Silergy' aggregate and cumulative liability towards customer for the products described herein shall be limited in accordance with the Standard Terms and Conditions of Sale of Silergy.

4. **Suitability for use.** Customer acknowledges and agrees that it is solely responsible for compliance with all legal, regulatory and safety-related requirements concerning its products, and any use of Silergy components in its applications, notwithstanding any applications-related information or support that may be provided by Silergy. Silergy products are not designed, authorized or warranted to be suitable for use in life support, life-critical or safety-critical systems or equipment, nor in applications where failure or malfunction of a Silergy product can reasonably be expected to result in personal injury, death or severe property or environmental damage. Silergy assumes no liability for inclusion and/or use of Silergy products in such equipment or applications and therefore such inclusion and/or use is at the customer's own risk.

5. **Terms and conditions of commercial sale.** Silergy products are sold subject to the standard terms and conditions of commercial sale, as published at <http://www.silergy.com/stdterms>, unless otherwise agreed in a valid written individual agreement specifically agreed to in writing by an authorized officer of Silergy. In case an individual agreement is concluded only the terms and conditions of the respective agreement shall apply. Silergy hereby expressly objects to and denies the application of any customer's general terms and conditions with regard to the purchase of Silergy products by the customer.

6. **No offer to sell or license.** Nothing in this document may be interpreted or construed as an offer to sell products that is open for acceptance or the grant, conveyance or implication of any license under any copyrights, patents or other industrial or intellectual property rights. Silergy makes no representation or warranty that any license, either express or implied, is granted under any patent right, copyright, mask work right, or other intellectual property right. Information published by Silergy regarding third-party products or services does not constitute a license to use such products or services or a warranty or endorsement thereof. Use of such information may require a license from a third party under the patents or other intellectual property of the third party, or a license from Silergy under the patents or other intellectual property of Silergy.

For more information, please visit: www.silergy.com

©2024 Silergy Corp.

All Rights Reserved.