



SY22646A

High Efficiency 60V, 0.8A, 350KHz Constant Current Step-down Regulator

General Description

SY22646A is a high efficiency, 12V-60V wide input voltage range DC/DC regulator targeting at LED lighting applications. The device integrates the low $R_{DS(ON)}$ MOSFET and internal compensation. Along with the small SO8E package, the device achieves an extremely small solution size for LED driver design. SY22646A also supports PWM dimming and Analog dimming function.

Features

- Low $R_{DS(ON)}$ for Internal Switches :680m Ω
- Input Range: 12V-60V
- 350kHz Switching Frequency
- 1.2A MOSFET Peak Current Limitation
- Analog/PWM Dimming Available
- Lower than 0.5% Deep Dimming Level
- Adjustable Thermal Foldback Temperature
- Dimming Resistor to Adjust Output Full Load
- Compact Package: SO8E

Ordering Information

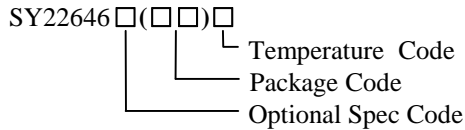

Ordering Number	Package type	Note
SY22646AFCC	SO8E	----

Applications

- PAR Lamp
- Tube Lamp
- Bulb

Typical Applications

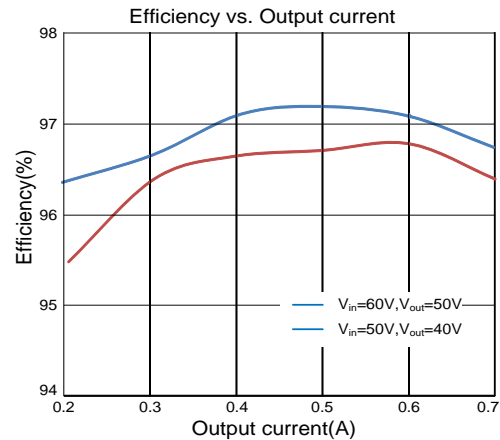
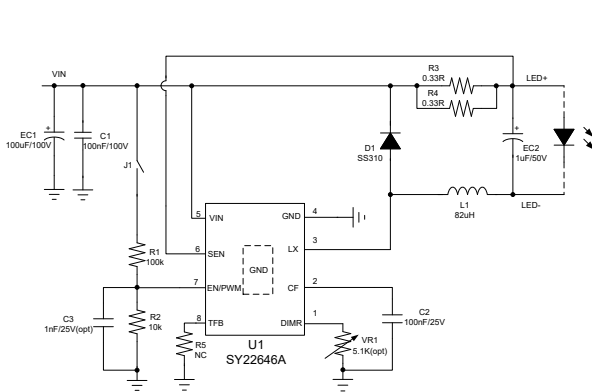
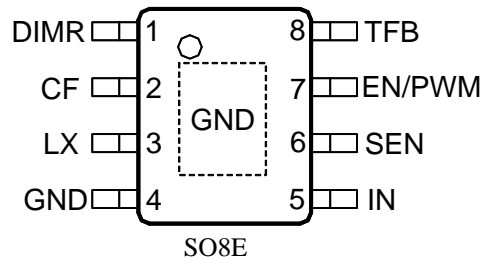

Figure 1. Schematic diagram

Pinout (top view)



Top Mark: BRLxyz (device code: BRL, *x*=year code, *y*=week code, *z*=lot number code)

PIN	Pin Name	Pin Description
1	DIMR	Resistor Dimming Pin, adjust output load from 100% to 75% by changing the external resistor. If no use, connect DIMR to GND.
2	CF	Dimming mode selection: $V_{CF} \geq 1.6V$, PWM ON/OFF dimming mode. $V_{CF} \leq 1.4V$, CF 0~1V analog dimming mode.
3	LX	Inductor node. Connect an inductor between negative of LED and LX Pin.
4	GND	Ground Pin
5	IN	Input Pin. Decouple this Pin to GND Pin with 1 μ F ceramic cap. Also used as the positive current sense Pin.
6	SEN	Negative Current Sense Pin.
7	EN/PWM	Dimming mode selection: 1. ON/OFF dimming mode : Connect EN/PWM Pin and CF Pin together, add PWM signal to PWM Pin, 2. 0~1.0V analog dimming mode: $V_{PWM} \geq 8.5V$, add 0~1.0V signal to CF Pin, at analog dimming mode, recommend to connect a 100nF capacitor between CF Pin and GND.
8	TFB	Thermal foldback temperature adjust Pin

Block Diagram

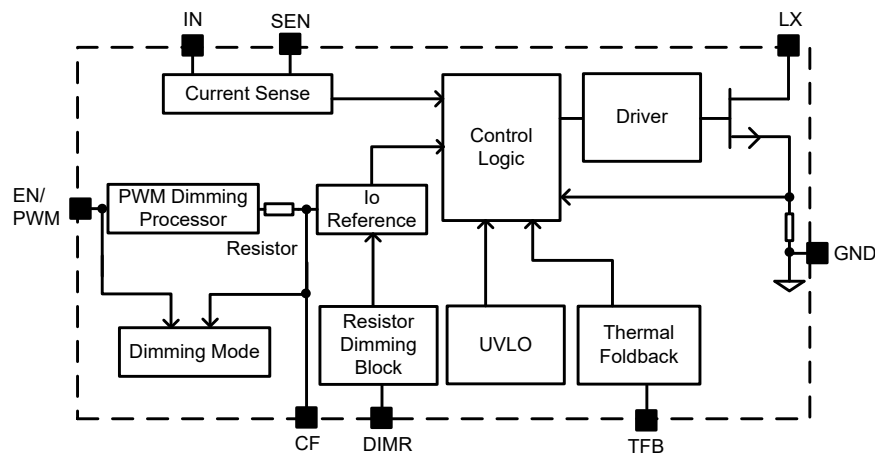



Absolute Maximum Ratings

LX, IN, PWM, CF	-0.3V to~ 63V
DIMR, TFB	-0.3V to~ 3.6V
SEN	-0.3V to $V_{IN}+0.6V$
Power Dissipation, PD @ $T_A = 25^{\circ}C$ SO8E,	3.3W
Package Thermal Resistance (Note 2)	
θ_{JA}	30°C/W
θ_{JC}	10°C/W
Junction Temperature Range	-40°C to 150°C
Lead Temperature (Soldering, 10 sec.)	260°C
Storage Temperature Range	-65°C to 150°C

Recommended Operating Conditions

IN	12V to 60V
SEN	$V_{IN}+0.4V$
Junction Temperature Range	-40°C to 125°C

Electrical Characteristics

(VIN =48V, Vout=36V, Iout=100mA, TA = 25°C unless otherwise specified)

Parameter	Symbol	Test Conditions	Min	Typ	Max	Unit
Power Supply Section						
Input Voltage Range	V _{IN}		12		60	V
Input UVLO Threshold	V _{UVLO_RISE}		9.8	10.4	10.9	V
Input UVLO Hysteresis	V _{UVLO_HYS}			2		V
Shutdown Current	I _{SHDN}	EN/PWM=0	5.5	8	11	μA
Operating Current	I _{VIN}	EN/PWM=3.3V	0.6	0.8	1	mA
Error Amplifier Section						
Internal Current Sense Reference	V _{IN_SEN}		98	100	102	mV
Min Current Sense Reference	V _{IN_SEN_MIN}		8.4	10	11.6	mV
Short Circuit Section						
Short Circuit Protection Voltage	V _{IN_SEN}		140	200	250	mV
Short circuit Recover Voltage	V _{IN_SEN_RC}		20	37	56	mV
Frequency Section						
Switching Frequency	F _s		280	350	410	kHz
Integrated MOSFET Section						
MOSFET ON Resistor	R _{DS(ON)}		600	680	800	mΩ
PWM Pin Section						
PWM ON Voltage	V _{PWM_ON}		1.7			V
PWM OFF Voltage	V _{PWM_OFF}				0.5	V
CF Pin Section						
CF ON Voltage	V _{CF_ON}			75		mV
CF OFF Voltage	V _{CF_OFF}			50		mV
Linear Dimming Range On CF	V _{CF}		100		950	mV
Other Section						
Thermal Foldback Temperature	T _{FB}	R _{FB} =0		105		°C
		R _{FB} ≥100k		155		
Thermal Shutdown Temperature	T _{SD}			T _{FB} +10		°C

Note 1: Stresses beyond the “Absolute Maximum Ratings” may cause permanent damage to the device. These are stress ratings only. Functional operation of the device at these or any other conditions beyond those indicated in the operational sections of the specification is not implied. Exposure to absolute maximum rating conditions for extended periods may affect device reliability.

Note 2: θ_{JA} is measured in the natural convection at TA = 25°C on a low effective single layer thermal conductivity test board of JEDEC 51-3 thermal measurement standard.

Note 3: The device is not guaranteed to function outside its operating conditions

Typical Performance Characteristics

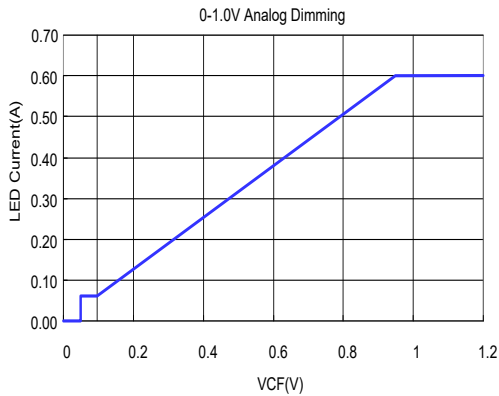

CF 0~1V dimming mode ($R_{DIMR}=0$)

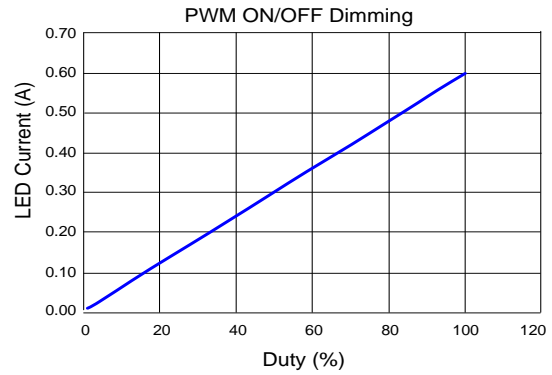

PWM ON/OFF dimming mode ($R_{DIMR}=0$)

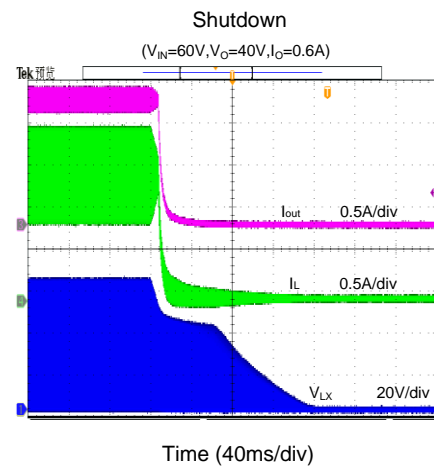
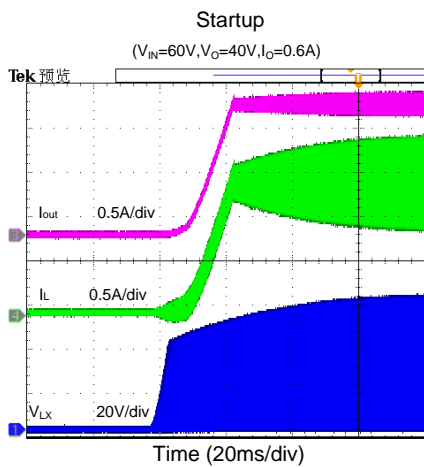
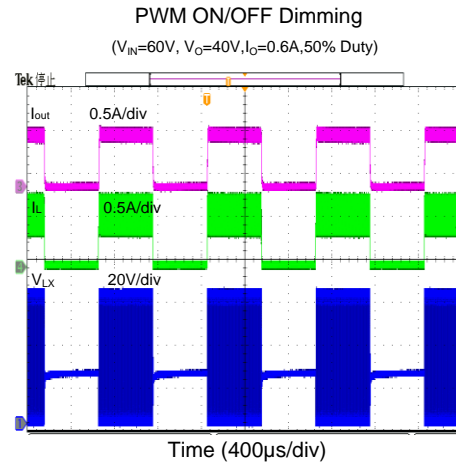
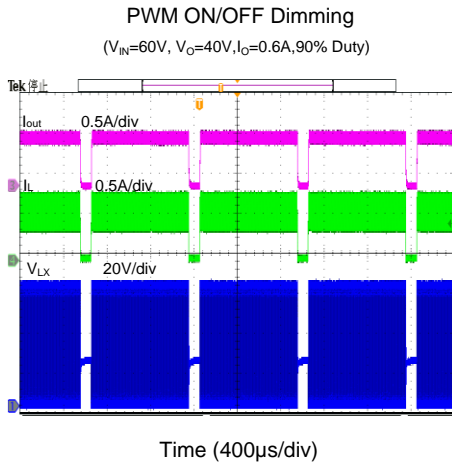

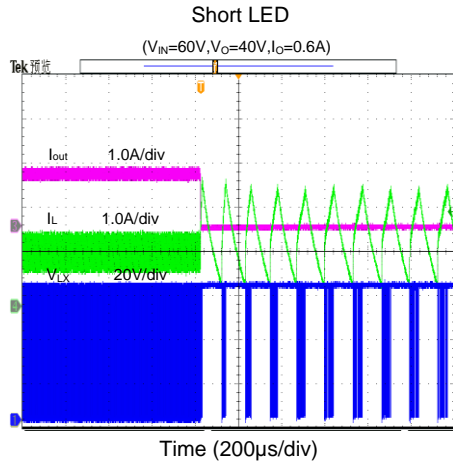

Operation

SY22646A is a grounding switch buck regulator IC that integrates the PWM control, power MOSFET on the same die to minimize the switching transition loss and conduction loss. With ultra low $R_{DS(ON)}$ power MOSFET and proprietary PWM control, this regulator IC can achieve the high efficiency and Along with the small SO8E package, the device achieves an extremely small solution size for LED driver design. SY22646A also supports PWM/Analog dimming function.

Applications Information

Because of the high integration in the SY22646A IC, the application circuit based on this regulator IC is rather simple. Only input capacitor C_{IN} , output capacitor C_{OUT} , output inductor L and current sense resistor R_{SEN} need to be selected for the targeted applications specifications.

Current Sense Resistor R_{SEN} :

Choose R_{SEN} to program the proper output Current:

$$I_{LED}(A) = \frac{0.1(V)}{R_{SEN}(\Omega)}$$

Input Capacitor C_{IN} :

The ripple current through input capacitor is calculated as:

$$I_{CIN_RMS} = I_{OUT} \cdot \sqrt{D(1-D)}$$

A typical X7R or better grade ceramic capacitor with suitable capacitance should be chosen to handle this ripple current well. To minimize the potential noise problem, place this ceramic capacitor really close to the IN and GND pins. Care should be taken to minimize the loop area formed by C_{IN} , and IN/GND pins.

Output Capacitor C_{OUT} :

The output capacitor is selected to handle the output current ripple noise requirements. For the best performance, it is recommended to use X7R or better grade ceramic capacitor greater than 1 μ F capacitance.

Output Inductor L :

There are several considerations in choosing this inductor.

- 1) Choose the inductance to provide the desired ripple current. It is suggested to choose the ripple current to be about 40% of the maximum output current. The inductance is calculated as:

$$L = \frac{V_{OUT}(1 - V_{OUT}/V_{IN,MAX})}{f_s \times I_{OUT,MAX} \times 40\%}$$

where f_s is the switching frequency and $I_{OUT,MAX}$ is the LED current.

The SY22646A regulator IC is quite tolerant of different ripple current amplitude. Consequently, the final choice of inductance can be slightly off the calculation value without significantly impacting the performance.

- 2) The saturation current rating of the inductor must be selected to be greater than the peak inductor current under full load conditions.

$$I_{SAT, MIN} > I_{OUT, MAX} + \frac{V_{OUT}(1-V_{OUT}/V_{IN,MAX})}{2 \cdot F_{SW} \cdot L}$$

Dimming Operation:

Dimming Mode:

1: PWM ON/OFF dimming. Connect EN/PWM Pin and CF Pin together, add PWM signal to PWM Pin.

2: 0~1.0V analog dimming. Set $V_{EN} \geq 8.5V$, and add 0~1.0V dimming signal to CF PIN.

Dimming mode	PWM	CF
PWM ON/OFF dimming	Connect PWM and CF together	
0~1.0V analog dimming	$PWM \geq 8.5V$	$\leq 1.4V$

At PWM dimming mode, the minimum T_{PWM_ON} time is suggest setting bigger than 20 μ s.

Soft Start:

Add a ceramic capacitor C_{CF} on CF to achieve soft start, the soft start time can be adjusted by C_{CF} .

SCP:

If $V_{VIN}-V_{SEN} \geq 200mV$, PWM is disabled, When $V_{VIN}-V_{SEN} = 35mV$, IC will recover work.

EN OFF:

IC shut down after EN OFF with 18.5ms.

Rdimr Dimming:

Add R_{DIMR} between DIMR and GND, 56 μ A current is output from DIMR PIN. The max output current vary from 100% to 75% by changing R_{DIMR} , and V_{DD} (1v) is became $V_{DD}-I_{DIMR} \cdot R_{DIMR}$. No matter how R_{DIMR} changes, The max of $I_{DIMR} \cdot R_{DIMR}$ is keeping 250mV, as well V_{REF} is keeping 5mV when $V_{CF} \leq 0.1V$.

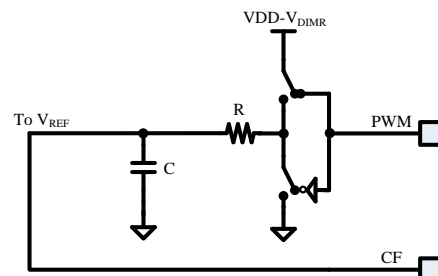

The max output current $I_o\%$ curve with R_{DIMR} as below:

SO8E Package Outline & PCB layout

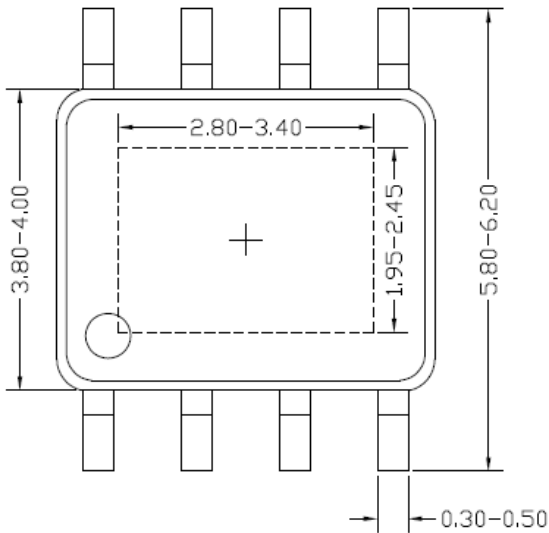

Top view

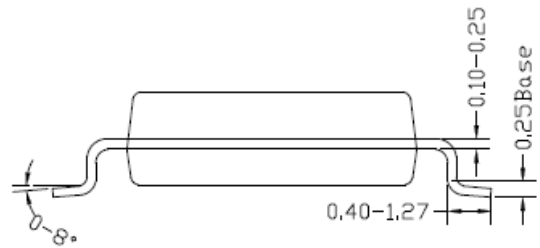

Side view

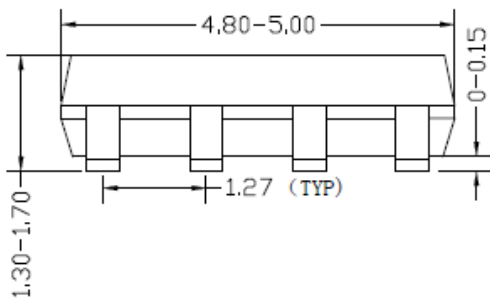

Front view

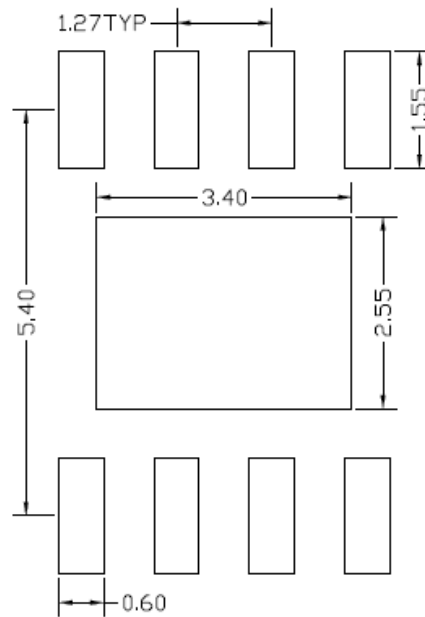

Recommended PCB Layout
(Reference Only)

Notes: All dimension in millimeter and exclude mold flash & metal burr.

Taping & Reel Specification

1. SO8E

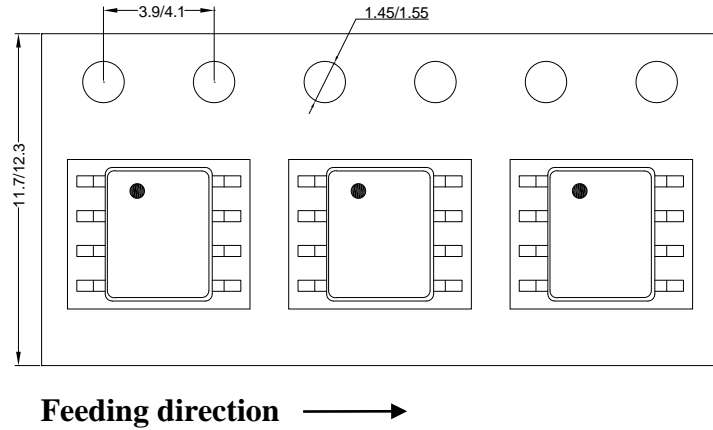

2. Carrier Tape & Reel specification for packages

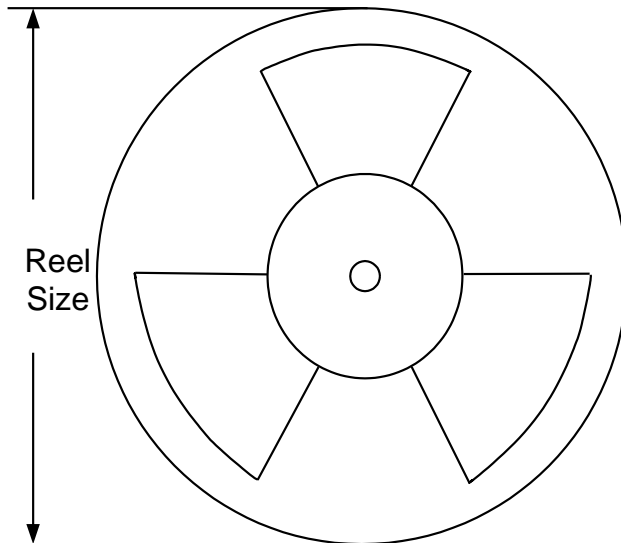

Package types	Tape width (mm)	Pocket pitch(mm)	Reel size (Inch)	Trailer length(mm)	Leader length (mm)	Qty per reel
SO8E	12	8	13"	400	400	2500

3. Others: NA

Revision History

The revision history provided is for informational purpose only and is believed to be accurate, however, not warranted. Please make sure that you have the latest revision.

Date	Revision	Change
June 17, 2020	Revision 1.0	Initial Production Release
June 17, 2019	Revision 0.9	Initial Risk Production Release

IMPORTANT NOTICE

1. **Right to make changes.** Silergy and its subsidiaries (hereafter Silergy) reserve the right to change any information published in this document, including but not limited to circuitry, specification and/or product design, manufacturing or descriptions, at any time and without notice. This document supersedes and replaces all information supplied prior to the publication hereof. Buyers should obtain the latest relevant information before placing orders and should verify that such information is current and complete. All semiconductor products are sold subject to Silergy’s standard terms and conditions of sale.
2. **Applications.** Application examples that are described herein for any of these products are for illustrative purposes only. Silergy makes no representation or warranty that such applications will be suitable for the specified use without further testing or modification. Buyers are responsible for the design and operation of their applications and products using Silergy products. Silergy or its subsidiaries assume no liability for any application assistance or designs of customer products. It is customer’s sole responsibility to determine whether the Silergy product is suitable and fit for the customer’s applications and products planned. To minimize the risks associated with customer’s products and applications, customer should provide adequate design and operating safeguards. Customer represents and agrees that it has all the necessary expertise to create and implement safeguards which anticipate dangerous consequences of failures, monitor failures and their consequences, lessen the likelihood of failures that might cause harm and take appropriate remedial actions. Silergy assumes no liability related to any default, damage, costs or problem in the customer’s applications or products, or the application or use by customer’s third-party buyers. Customer will fully indemnify Silergy, its subsidiaries, and their representatives against any damages arising out of the use of any Silergy components in safety-critical applications. It is also buyers’ sole responsibility to warrant and guarantee that any intellectual property rights of a third party are not infringed upon when integrating Silergy products into any application. Silergy assumes no responsibility for any said applications or for any use of any circuitry other than circuitry entirely embodied in a Silergy product.
3. **Limited warranty and liability.** Information furnished by Silergy in this document is believed to be accurate and reliable. However, Silergy makes no representation or warranty, expressed or implied, as to the accuracy or completeness of such information and shall have no liability for the consequences of use of such information. In no event shall Silergy be liable for any indirect, incidental, punitive, special or consequential damages, including but not limited to lost profits, lost savings, business interruption, costs related to the removal or replacement of any products or rework charges, whether or not such damages are based on tort or negligence, warranty, breach of contract or any other legal theory. Notwithstanding any damages that customer might incur for any reason whatsoever, Silergy’ aggregate and cumulative liability towards customer for the products described herein shall be limited in accordance with the Standard Terms and Conditions of Sale of Silergy.
4. **Suitability for use.** Customer acknowledges and agrees that it is solely responsible for compliance with all legal, regulatory and safety-related requirements concerning its products, and any use of Silergy components in its applications, notwithstanding any applications-related information or support that may be provided by Silergy. Silergy products are not designed, authorized or warranted to be suitable for use in life support, life-critical or safety-critical systems or equipment, nor in applications where failure or malfunction of an Silergy product can reasonably be expected to result in personal injury, death or severe property or environmental damage. Silergy assumes no liability for inclusion and/or use of Silergy products in such equipment or applications and therefore such inclusion and/or use is at the customer’s own risk.
5. **Terms and conditions of commercial sale.** Silergy products are sold subject to the standard terms and conditions of commercial sale, as published at <http://www.silergy.com/stdterms>, unless otherwise agreed in a valid written individual agreement specifically agreed to in writing by an authorized officer of Silergy. In case an individual agreement is concluded only the terms and conditions of the respective agreement shall apply. Silergy hereby expressly objects to and denies the application of any customer’s general terms and conditions with regard to the purchase of Silergy products by the customer.
6. **No offer to sell or license.** Nothing in this document may be interpreted or construed as an offer to sell products that is open for acceptance or the grant, conveyance or implication of any license under any copyrights, patents or other industrial or intellectual property rights. Silergy makes no representation or warranty that any license, either express or implied, is granted under any patent right, copyright, mask work right, or other intellectual property right. Information published by Silergy regarding third-party products or services does not constitute a license to use such products or services or a warranty or endorsement thereof. Use of such information may require a license from a third party under the patents or other intellectual property of the third party, or a license from Silergy under the patents or other intellectual property of Silergy.

For more information, please visit: www.silergy.com

© 2019 Silergy Corp.

All Rights Reserved.