

Pinout (top view)

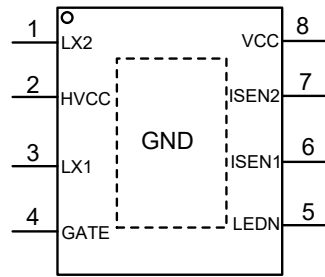

(SO8E)

Part Number	Package type	Top Mark [Ⓞ]
SY22638A2FCP	SO8E	EDQxyz
SY22638B4FCP	SO8E	EDRxyz

Note ①: x=year code, y=week code, z=lot number code

Pin Name	Pin number	Pin Description
LX2	1	Drain of Bleeding MOS pin.
HVCC	2	HV power supply pin.
LX1	3	Drain of Main MOS pin.
GATE	4	Gate of integrated current ripple remover MOSFET.
LEDN	5	Connect to the Cathode of LED load.
ISEN1	6	Main MOS Current Sense Pin. The output current is decided by $I_{OUT} = \frac{V_{REF}}{R_{ISEN1} + R_{ISEN2}}$
ISEN2	7	BLD MOS Current Sense Pin. Latching current is adjusted by R _{ISEN2} . Recommended value: R _{ISEN2} > 0.75 ohm.
VCC	8	Power supply pin.
GND	9	Ground.

Block Diagram

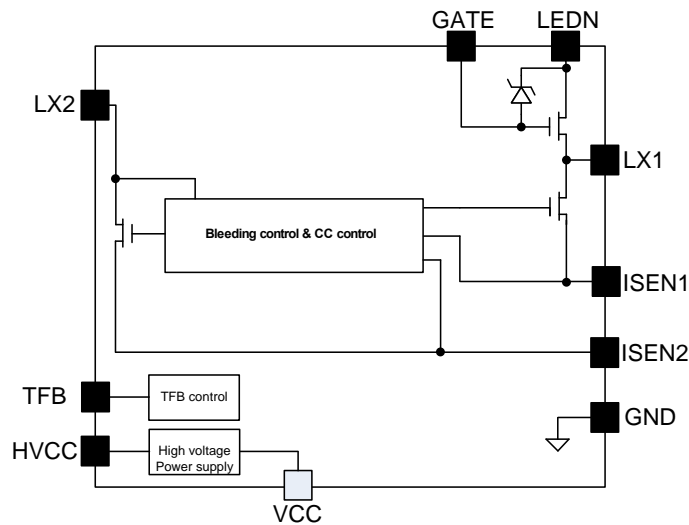

Figure.3 Block Diagram

Absolute Maximum Ratings (Note 1)

LX2, HVCC	-----	-0.3V~700V
LX1, GATE, LEDN	-----	-0.3V~500V
ISEN1, ISEN2	-----	-0.3V~3.6V
VCC	-----	-0.3~ 25V
LEDN to LX1	-----	-0.3~ 20V
GATE to LX1	-----	-0.3~ 3.6V
Power Dissipation, @ T _A = 25°C SO8E	-----	3.3W
Package Thermal Resistance (Note 2)		
SO8E, θ_{JA}	-----	30°C/W
SO8E, θ_{JC}	-----	10°C/W
Junction Temperature Range	-----	-40°C to 150°C
Lead Temperature (Soldering, 10 sec.)	-----	260°C
Storage Temperature Range	-----	-65°C to 150°C

Recommended Operating Conditions (Note 3)

Junction Temperature Range	-----	-40°C to 150°C
Ambient Temperature Range	-----	-40°C to 120°C

Electrical Characteristics

(V_{IN} = 15V (Note 3), T_A = 25°C unless otherwise specified)

Parameter	Symbol	Test Conditions	Min	Typ	Max	Unit
Power Supply Section						
VIN Turn-on Threshold	V _{VIN_ON}			12		V
VIN Turn-off Threshold	V _{VIN_OFF}			8.8		V
Quiescent Current	I _Q			350		μA
Error Amplifier Section						
Internal Reference Voltage	V _{REF}			0.3		V
MOS Section						
BV of LX1 MOS	V _{BV_LX1}		500			V
BV of LX2 MOS	V _{BV_LX2}		700			V
Inter Ripple Remover Section						
Zener Voltage between LEDN and GATE of SY22638A2	V _{Zener}			11.5		V
Zener Voltage between LEDN and GATE of SY22638B4	V _{Zener}			18		V
Thermal Section						
Thermal Foldback Temperature	T _{FB}			155		°C

Note 1: Stresses beyond the “Absolute Maximum Ratings” may cause permanent damage to the device. These are stress ratings only. Functional operation of the device at these or any other conditions beyond those indicated in the operational sections of the specification is not implied. Exposure to absolute maximum rating conditions for extended periods may affect device reliability.

Note 2: θ_{JA} is measured in the natural convection at T_A = 25°C on a low effective single layer thermal conductivity test board of JEDEC 51-3 thermal measurement standard. Test condition: Device mounted on 2” x 2” FR-4 substrate PCB, 2oz copper, with minimum recommended pad on top layer and thermal vias to bottom layer ground plane.

Note 3: Increase VIN pin voltage gradually higher than V_{VIN_ON} voltage then turn down to 12V.

Operation

SY22638A2/B4 is a HV TRIAC Linear Controller. It recognizes ac mode, leading edge mode, trailing edge mode automatically in first sixteen ac cycles.

It's integrated a current ripple remover to eliminate low frequency current ripple

For improving the efficiency, the current of LX1 is compensated by VBUS. In the peak voltage of VBUS, the current of LX1 is the smallest, and then the loss is decreased.

In leading edge mode, SY22638A2/B4 controls the fire current automatically which is the Silergy exclusive patent.

For trailing edge dimmer, SY22638A2/B4 has a good performance by Reliable reset control.

TFB is available to be set for different application.

PF is higher than 0.7 suitable for European market.

Applications Information

AC Mode

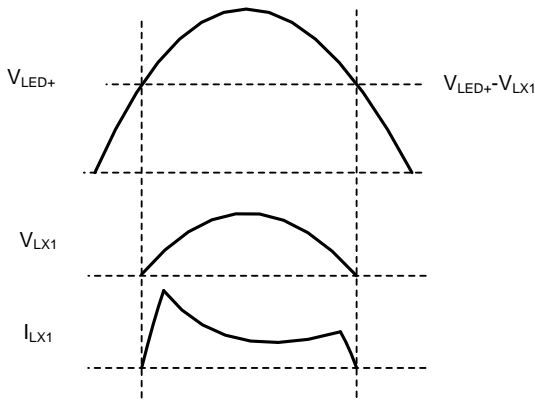

Fig.4 state in ac mode

In ac mode, the wave is showed above. The current of LX1 is compensated by VBUS for good efficiency performance.

In any kinds of mode, the output current is regulated by ISEN1 and ISEN2.

$$I_{OUT} = \frac{V_{REF}}{R_{ISEN1} + R_{ISEN2}}$$

Trailing edge mode

In trailing edge mode, SY22638A2/B4 tries to reset the dimmer when the current of LX1 MOS is off. As showed below.

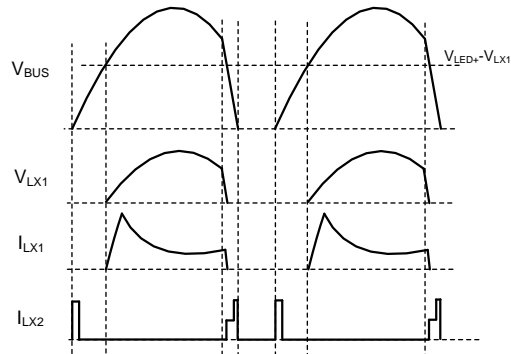

Fig.5 state in trailing edge mode

Trailing edge mode

In trailing edge mode, the fire current is decided by the resistor of ISEN2.

With smaller R_{ISEN2} , the latching current of LX2 is larger. For improving the efficiency, recommend to choose larger value of R_{ISEN2} , and satisfy appropriate compatibility.

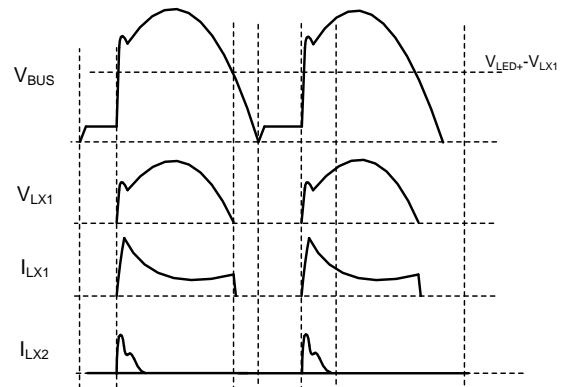

Fig.6 state in leading edge mode

The current of LX1 and LX2 flow through R_{ISEN2} simultaneously. So the actual fire current contains both two currents which help to decrease the fire loss. Recommend value: $R_{ISEN1} > 0.7 \text{ ohm}$.

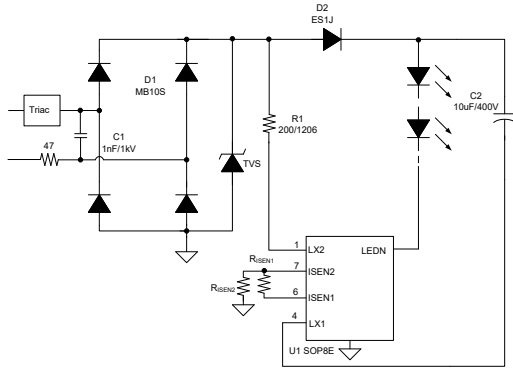

Fig.6 fire current sample resistor

CV logic

For further improve efficiency, SY22638A2/B4 integrate automatic CV regulation logic. So the loss caused by holding current is reduced.

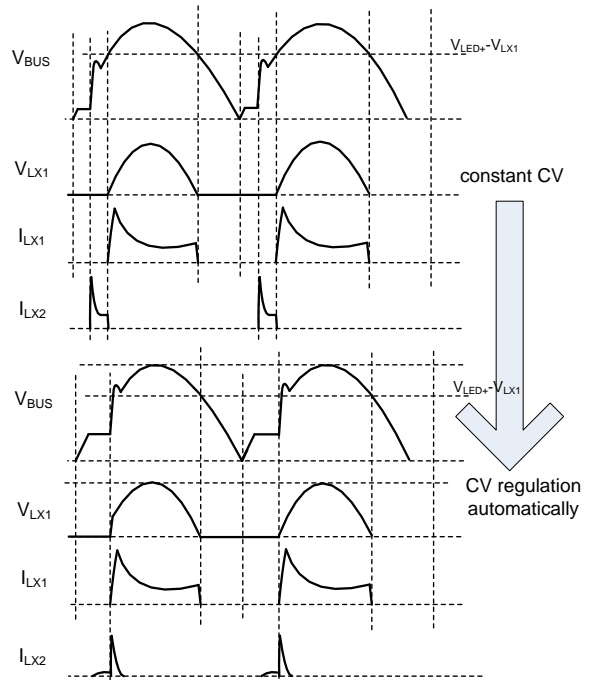

Fig.7 CV logic

Design Example

A design example of typical application is shown below step by step.

Example A

#1. Identify design specification

Target parameter			
I_{OUT}	22mA	T_{TFB}	150°

#1. Set R_{ISEN1} and R_{ISEN2}

Set $R_{ISEN2}=0.75\text{ ohm}$

$$R_{ISEN1} = \frac{V_{REF}}{I_{OUT}} - R_{ISEN2} = \frac{0.3}{0.022} - 0.75 \approx 13\text{ ohm}$$

#2 set TFB pin

$R_{TFB}=NC.$

#3 final result

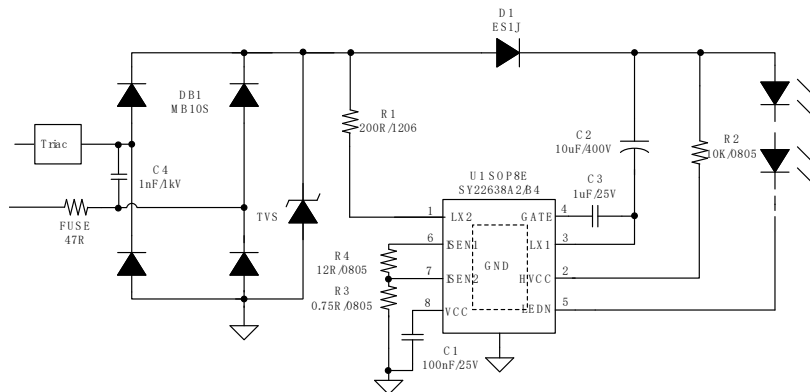
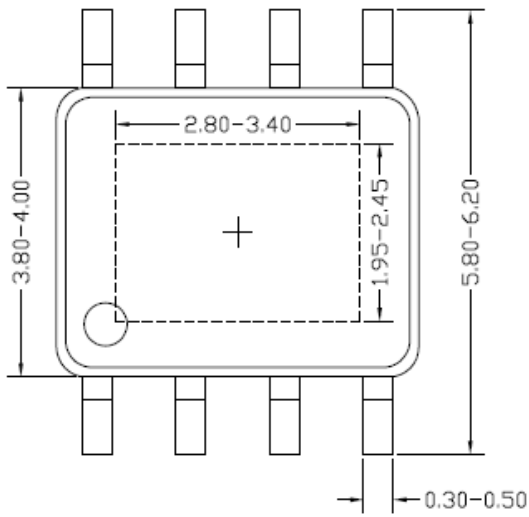
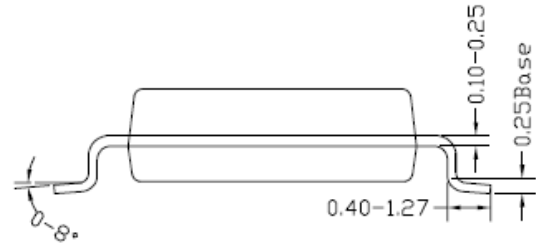

Fig.9 Final Design Result

SO8E Package Outline & PCB layout



Top view



Side view

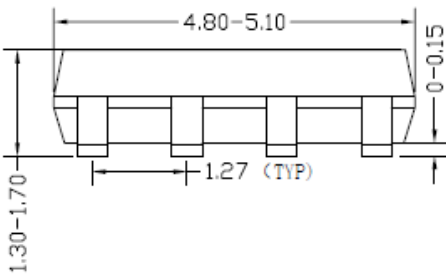

Front view

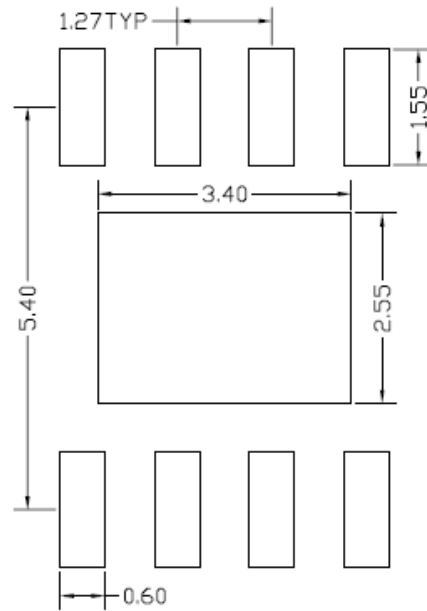

**Recommended PCB layout
(Reference Only)**

Notes: All dimension in millimeter and exclude mold flash & metal burr.

Taping & Reel Specification

1. Taping orientation

SO8E

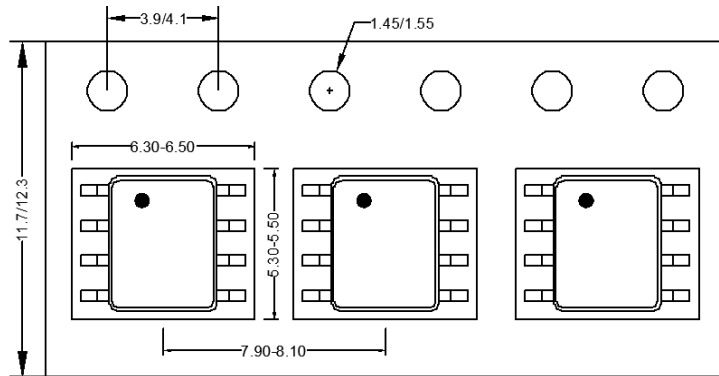

Feeding direction →

2. Carrier Tape & Reel specification for packages

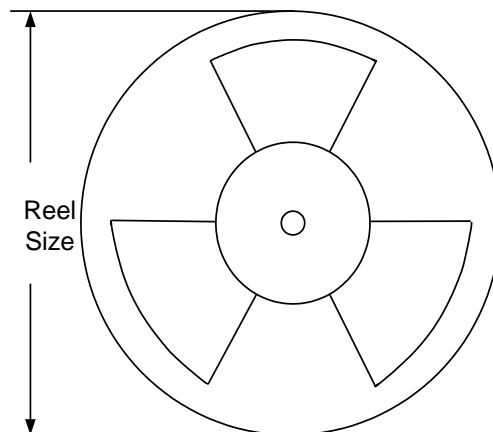

Package types	Tape width (mm)	Pocket pitch(mm)	Reel size (Inch)	Trailer * length(mm)	Leader * length (mm)	Qty per reel (pcs)
SO8E	12	8	13"	400	400	2500

Others: NA

Revision History

The revision history provided is for informational purpose only and is believed to be accurate, however, not warranted. Please make sure that you have the latest revision.

Date	Revision	Change
March 30, 2023	Revision 0.9	Initial Risk Production Release
March 30, 2024	Revision 1.0	Initial Production Release

IMPORTANT NOTICE

1. **Right to make changes.** Silergy and its subsidiaries (hereafter Silergy) reserve the right to change any information published in this document, including but not limited to circuitry, specification and/or product design, manufacturing or descriptions, at any time and without notice. This document supersedes and replaces all information supplied prior to the publication hereof. Buyers should obtain the latest relevant information before placing orders and should verify that such information is current and complete. All semiconductor products are sold subject to Silergy’s standard terms and conditions of sale.

2. **Applications.** Application examples that are described herein for any of these products are for illustrative purposes only. Silergy makes no representation or warranty that such applications will be suitable for the specified use without further testing or modification. Buyers are responsible for the design and operation of their applications and products using Silergy products. Silergy or its subsidiaries assume no liability for any application assistance or designs of customer products. It is customer’s sole responsibility to determine whether the Silergy product is suitable and fit for the customer’s applications and products planned. To minimize the risks associated with customer’s products and applications, customer should provide adequate design and operating safeguards. Customer represents and agrees that it has all the necessary expertise to create and implement safeguards which anticipate dangerous consequences of failures, monitor failures and their consequences, lessen the likelihood of failures that might cause harm and take appropriate remedial actions. Silergy assumes no liability related to any default, damage, costs or problem in the customer’s applications or products, or the application or use by customer’s third-party buyers. Customer will fully indemnify Silergy, its subsidiaries, and their representatives against any damages arising out of the use of any Silergy components in safety-critical applications. It is also buyers’ sole responsibility to warrant and guarantee that any intellectual property rights of a third party are not infringed upon when integrating Silergy products into any application. Silergy assumes no responsibility for any said applications or for any use of any circuitry other than circuitry entirely embodied in a Silergy product.

3. **Limited warranty and liability.** Information furnished by Silergy in this document is believed to be accurate and reliable. However, Silergy makes no representation or warranty, expressed or implied, as to the accuracy or completeness of such information and shall have no liability for the consequences of use of such information. In no event shall Silergy be liable for any indirect, incidental, punitive, special or consequential damages, including but not limited to lost profits, lost savings, business interruption, costs related to the removal or replacement of any products or rework charges, whether or not such damages are based on tort or negligence, warranty, breach of contract or any other legal theory. Notwithstanding any damages that customer might incur for any reason whatsoever, Silergy’ aggregate and cumulative liability towards customer for the products described herein shall be limited in accordance with the Standard Terms and Conditions of Sale of Silergy.

4. **Suitability for use.** Customer acknowledges and agrees that it is solely responsible for compliance with all legal, regulatory and safety-related requirements concerning its products, and any use of Silergy components in its applications, notwithstanding any applications-related information or support that may be provided by Silergy. Silergy products are not designed, authorized or warranted to be suitable for use in life support, life-critical or safety-critical systems or equipment, nor in applications where failure or malfunction of an Silergy product can reasonably be expected to result in personal injury, death or severe property or environmental damage. Silergy assumes no liability for inclusion and/or use of Silergy products in such equipment or applications and therefore such inclusion and/or use is at the customer’s own risk.

5. **Terms and conditions of commercial sale.** Silergy products are sold subject to the standard terms and conditions of commercial sale, as published at <http://www.silergy.com/stdterms>, unless otherwise agreed in a valid written individual agreement specifically agreed to in writing by an authorized officer of Silergy. In case an individual agreement is concluded only the terms and conditions of the respective agreement shall apply. Silergy hereby expressly objects to and denies the application of any customer’s general terms and conditions with regard to the purchase of Silergy products by the customer.

6. **No offer to sell or license.** Nothing in this document may be interpreted or construed as an offer to sell products that is open for acceptance or the grant, conveyance or implication of any license under any copyrights, patents or other industrial or intellectual property rights. Silergy makes no representation or warranty that any license, either express or implied, is granted under any patent right, copyright, mask work right, or other intellectual property right. Information published by Silergy regarding third-party products or services does not constitute a license to use such products or services or a warranty or endorsement thereof. Use of such information may require a license from a third party under the patents or other intellectual property of the third party, or a license from Silergy under the patents or other intellectual property of Silergy.

For more information, please visit: www.silergy.com

©2024 Silergy Corp.

All Rights Reserved.