

General Description

SY58978U is a single-stage Buck PFC driver for LED lighting applications.

SY58978U adopts the proprietary control architecture to achieve an accurate regulation of LED current, unity power factor. It drives the converter in Quasi-Resonant mode to achieve high efficiency.

SY58978U integrates 600V MOSFET inside to save driver space further.

SY58978U is available in SO8 package.

Features

- Power Factor >0.9
- 600V MOSFET Integrated
- Quasi-Resonant Operation
- Thermal Fold Back
- Low BOM Cost
- RoHS Compliant and Halogen Free
- Compact Package: SO8

Applications

- LED Lighting

Ordering Information

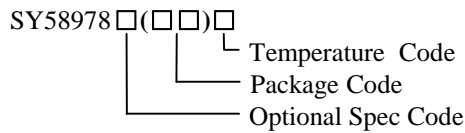

Ordering Number	Package type	Note
SY58978UFAC	SO8	----

Typical Applications

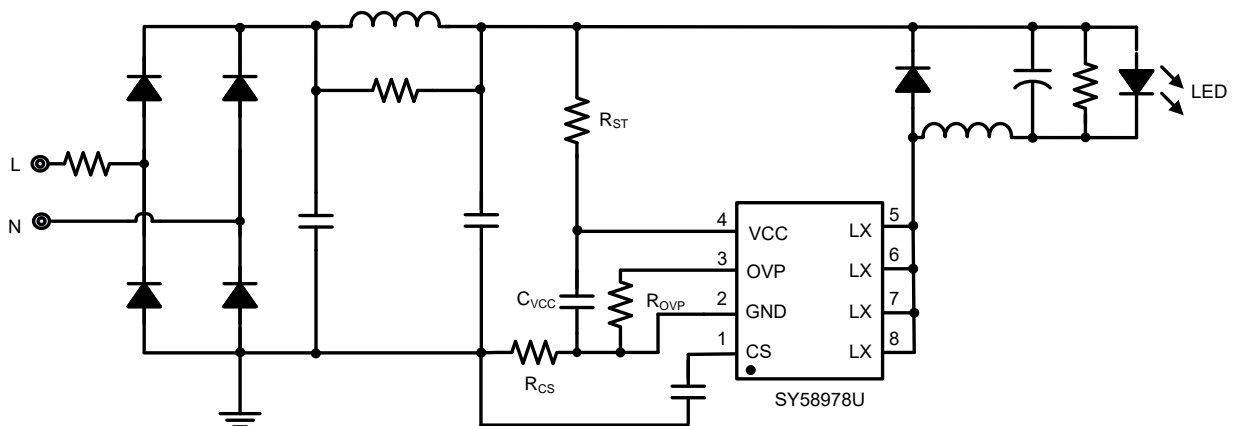
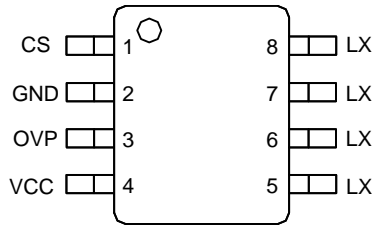

Figure 1. Typical application

Pinout (top view)



(SO8)

Top Mark: CDExyz (device code: CDE, *x*=year code, *y*=week code, *z*=lot number code)

Pin Name	PIN Number	Pin Description
CS	1	Current sense pin, connect a cap and sense res to GND pin. $R_{CS} = \frac{V_{REF}}{2I_O}$
GND	2	Ground pin.
OVP	3	Over voltage protection set pin. Connect a resistor to GND. $V_{OVP}(V) = \frac{K}{T_{OVP}} * \frac{L}{R_{OVP} * R_{CS}}$, $K=4400(V \cdot \Omega)$
VCC	4	Bias supply pin.
LX	5-8	Internal MOSFET drain node.

Block Diagram

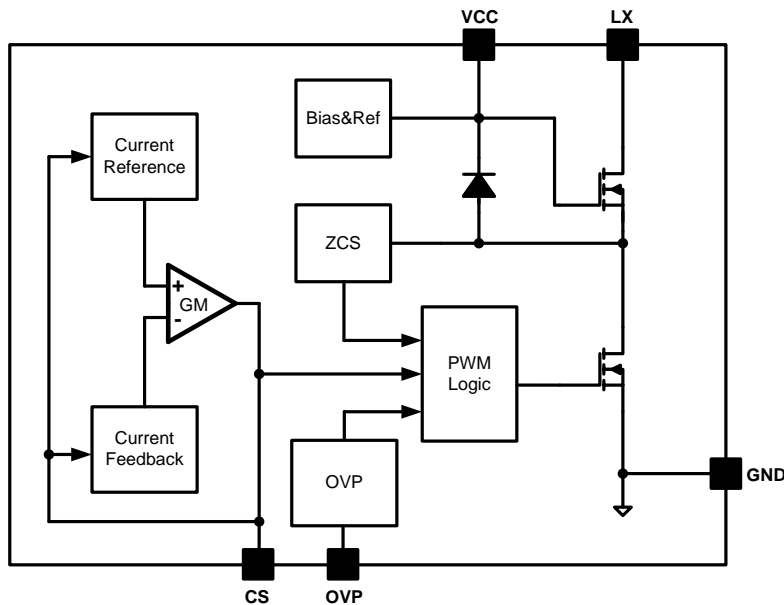

Fig.2 Simplified block diagram



Absolute Maximum Ratings (Note 1)

VCC	-0.3V~20V
I _{VCC}	4mA
CS, OVP	-0.3V~4V
LX	600V
Power Dissipation, @ TA = 25°C SO8	1.1W
Package Thermal Resistance (Note 2)	
SO8, θ_{JA}	88°C/W
SO8, θ_{JC}	45°C/W
Maximum Junction Temperature	165°C
Lead Temperature (Soldering, 10 sec.)	260°C
Storage Temperature Range	-65°C to 165°C

Recommended Operating Conditions

Junction Temperature Range	-40°C to 125°C
----------------------------	----------------

Electrical Characteristics

(VCC = 12V, TA = 25°C unless otherwise specified)

Parameter	Symbol	Test Conditions	Min	Typ	Max	Unit
Power Supply Section						
VCC turn-on threshold	V _{VCC,ON}		13.2	14.1	15.0	V
VCC turn-off threshold	V _{VCC,OFF}		6.90	7.45	8.00	V
VCC shunt voltage	V _{VCC,Shunt}	I _{VCC} ≥ 2mA	13.90	14.90	15.90	V
Start up current	I _{ST}	V _{VCC} = 12V	57	69	81	μA
Quiescent current	I _Q	LX = 30V	264	305	346	μA
CS pin Section						
Current reference	V _{REF}		206.5	212.5	218.5	mV
OVP pin Section						
OVP coefficient	T _{OVP}		10.3	11.6	12.8	μs
Driver Section						
Min ON Time	T _{ON,MIN}			785		ns
Max ON Time	T _{ON,MAX}			17.2		μs
Min OFF Time	T _{OFF,MIN}			2.04		μs
Max OFF Time	T _{OFF,MAX}	V _{CS} ≤ 50mV		75		μs
Integrated MOSFET Section						
BV of HV MOSFET	V _{BV}		600			V
HV MOS Drain source resistance	R _{DSON,H}			2.45	3.00	Ω
Thermal Section						
Thermal fold back temperature	T _{FB}			155		°C
Thermal shut down temperature	T _{SD}			T _{FB} + 5		°C

Note 1: Stresses beyond the “Absolute Maximum Ratings” may cause permanent damage to the device. These are stress ratings only. Functional operation of the device at these or any other conditions beyond those indicated in the operational sections of the specification is not implied. Exposure to absolute maximum rating conditions for extended periods may affect device reliability.

Note 2: θ_{JA} is measured in the natural convection at TA = 25°C on a low effective single layer thermal conductivity test board of JEDEC 51-3 thermal measurement standard. Test condition: Device mounted on 2” x 2” FR-4 substrate PCB, 2oz copper, with minimum recommended pad on top layer and thermal vias to bottom layer ground plane

Note 3: The device is not guaranteed to function outside its operating conditions.

Operation

SY58978U is a constant current Buck PFC regulator targeting at LED lighting applications.

It integrates a MOSFET with 600V breakdown voltage to decrease physical volume.

High power factor is achieved by constant on-time operation mode, with which the control scheme and the circuit structure are both simple.

In order to reduce the switching losses and improve EMI performance, Quasi-Resonant switching mode is applied, which means to turn on the power MOSFET at voltage valley;

SY58978U provides reliable protections such as Short Circuit Protection (SCP), Open LED Protection (OLP), and Over Temperature Protection (OTP).

SY58978U is available with SO8

Applications Information

Start up

After AC supply or DC BUS is powered on, the capacitor C_{VCC} across VCC and GND pin is charged up by BUS voltage through a start up resistor R_{ST} . Once V_{VCC} rises up to V_{VCC_ON} , the internal blocks start to work and V_{CS} is pre-charged to certain value.

The whole start up procedure is divided into three sections as shown below. t_{ST1} is the C_{VCC} charged up time. t_{ST2} is the time V_{CS} is charged up to certain value. t_{ST3} is the time IC works at steady state. Usually t_{ST2} is much smaller than t_{ST1} .

If bias supply has more power than IC consumption, V_{VCC} is greater than V_{VCC_Shunt} , and then a shunt current starts to work.

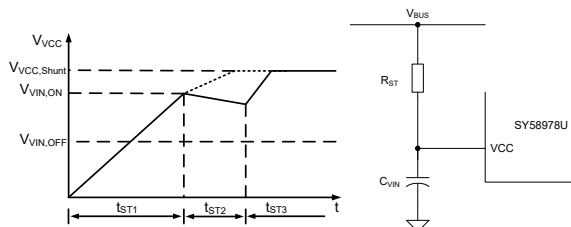

Fig. Start up

The start up resistor R_{ST} and C_{VCC} are designed by rules below:

(a) Preset start-up resistor R_{ST} , make sure that the current through R_{ST} is larger than I_{ST} .

$$R_{ST} < \frac{V_{BUS}}{I_{ST}}$$

Where V_{BUS} is the BUS line voltage.

(b) Select C_{VCC} to obtain an ideal start up time t_{ST} , and ensure the output voltage is built up at one time.

$$C_{VCC} = \frac{(\frac{V_{BUS}}{R_{ST}} - I_{ST}) \times t_{ST}}{V_{VCC_ON}}$$

Shut down

After AC supply or DC BUS is powered off, the energy stored in the BUS capacitor will be discharged. When the power supply for IC is not enough, V_{VCC} will drop down. Once V_{VCC} is below V_{VCC_OFF} , the IC will stop working.

Constant-current control

The output current I_{OUT} can be represented by

$$I_{OUT} = \frac{V_{REF}}{R_{CS} \times 2}$$

Where V_{REF} is the internal reference voltage; R_{CS} is the current sense resistor.

Quasi-Resonant Operation

QR mode operation provides low turn-on switching losses for Buck converter.

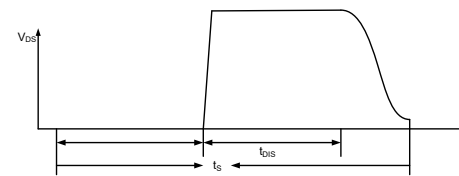

Fig. QR mode operation

When the voltage across drain and source of the MOSFET is at voltage valley, the MOSFET would be turned on.

Open LED Protection (OLP)

The protection voltage V_{OVP} for open LED is set by the resistor R_{OVP} between OVP and GND pin. The relationship is shown as below:

$$V_{OVP} = \frac{K_{OVP}}{T_{OVP}} \times \frac{L_M}{R_{CS} \times R_{OVP}}, K = 4400(V \times \Omega)$$

If over voltage protection is triggered, the PWM output is stopped, V_{CS} and V_{VCC} is discharged for three times and then start up again.

Short Circuit Protection (SCP)

If LED is short, bias supply is not enough, and then V_{VCC} is discharged. Once V_{VCC} drops down to V_{VCC_OFF} , the IC stops working, and then starts up again.

Power Device Design

MOSFET and Diode

When the operation condition is with maximum input voltage and full load, the voltage stress of MOSFET and output power diode is maximized;

$$V_{MOS_DS_MAX} = \sqrt{2}V_{AC_MAX}$$

$$V_{D_R_MAX} = \sqrt{2}V_{AC_MAX}$$

Where V_{AC_MAX} is maximum input AC RMS voltage. When the operation condition is with minimum input voltage and full load, the current stress of MOSFET and power diode is maximized.

Inductor (L)

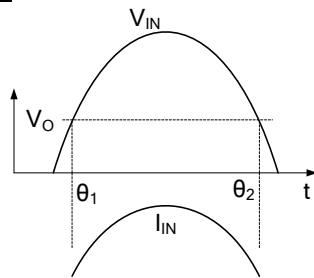

Fig. input waveforms

The power is transferred from AC input to output only when the input voltage is larger than output voltage in Buck converter. The input voltage and inductor current waveforms are shown above, where θ_1 and θ_2 are the time that input voltage is equal to output voltage.

In Quasi-Resonant mode, each switching period cycle t_s consists of three parts: current rising time t_1 , current falling time t_2 and quasi-resonant time t_3 shown in below.

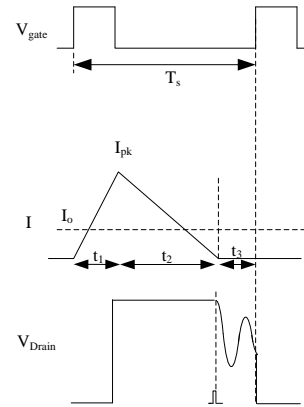

Fig. switching waveforms

The system operates in the constant on time mode to achieve high power factor. The ON time increases with the input AC RMS voltage decreasing and the load increasing. When the operation condition is with minimum input AC RMS voltage and full load, the ON time is maximized. On the other hand, when the input voltage is at the peak value, the OFF time is maximized. Thus, the minimum switching frequency f_{S_MIN} happens at the peak value of input voltage with minimum input AC RMS voltage and maximum load condition; meanwhile, the maximum peak current through MOSFET and the transformer happens.

Once the minimum frequency f_{S_MIN} is set, the inductance of the transformer could be calculated. The design flow is shown as below:

(a) Preset minimum frequency f_{S_MIN}

(b) Compute relative t_s, t_1

$$t_s = \frac{1}{f_{S_MIN}}$$

$$t_1 = \frac{t_s \times (V_{OUT} + V_{DF})}{(\sqrt{2}V_{AC_MIN} + V_{DF})}$$

$$t_2 = t_s - t_1$$

Where V_{DF} is the forward voltage of the diode

(c) Design inductance L

$$\theta_1 = \arcsin\left(\frac{V_{OUT}}{\sqrt{2}V_{AC_MIN}}\right) \times \frac{1}{\pi} \times \frac{1}{2 \times f_{AC}}$$

$$\theta_2 = \frac{1}{2 \times f_{AC}} - \theta_1$$

$$L = \frac{\eta \times f_{AC} \times V_{OUT} \times t_1}{P_{OUT}} \times [\sqrt{2}V_{AC_MIN} \times \frac{\cos(2\pi f_{AC} \times \theta_1) - \cos(2\pi f_{AC} \times \theta_2)}{2\pi f_{AC}} - V_{OUT}(\theta_2 - \theta_1)]$$

Where η is the efficiency; P_{OUT} is rated full load power;

(d) Compute inductor maximum peak current $I_{L_PK_MAX}$.

$$I_{L_PK_MAX} = \frac{(\sqrt{2}V_{AC_MIN} - V_{OUT}) \times t_1}{L}$$

Where $I_{L_PK_MAX}$ is maximum inductor peak current;

(e) Compute RMS current of the inductor

$I_{L_RMS_MAX}$ is Inductor RMS current of whole AC period

$$I_{L_RMS_MAX} = \frac{t_1}{\sqrt{3} \times L} \sqrt{V_{AC_MIN}^2 + V_{OUT}^2 - \frac{4\sqrt{2}V_{AC_MIN} \times V_{OUT}}{\pi}}$$

(f) Compute RMS current of the MOSFET

$$I_{L_RMS_MAX} = \sqrt{\frac{t_1}{3t_s}} \times \frac{t_1}{L} \sqrt{V_{AC_MIN}^2 + V_{OUT}^2 - \frac{4\sqrt{2}V_{AC_MIN} \times V_{OUT}}{\pi}}$$

Inductor design (N)

The parameters below are necessary:

Necessary parameters	
Inductance	L
inductor maximum current	$I_{L_PK_MAX}$

The design rules are as followed:

(a) Select the magnetic core style, identify the effective area A_e .

(b) Preset the maximum magnetic flux ΔB

$$\Delta B = 0.22 \sim 0.26 T$$

(c) Compute primary turn N

$$N = \frac{L_M \times I_{L_PK_MAX}}{\Delta B \times A_e}$$

(d) Select an appropriate wire diameter with $I_{L_RMS_MAX}$, select appropriate wire to make sure the current density ranges from 4A/mm² to 10A/mm².

(e) If the winding area of the core and bobbin is not enough, reselect the core style, go to (a) and redesign the transformer until the ideal transformer is achieved.

Output capacitor C_{OUT}

Preset the output current ripple ΔI_{OUT} , C_{OUT} is induced by

$$C_{OUT} = \frac{\sqrt{\left(\frac{2I_{OUT}}{\Delta I_{OUT}}\right)^2 - 1}}{4\pi f_{AC} R_{LED}}$$

Where I_{OUT} is the rated output current; ΔI_{OUT} is the demanded current ripple; f_{AC} is the input AC supply frequency; R_{LED} is the equivalent series resistor of the LED load.

SO8 Package outline & PCB layout design

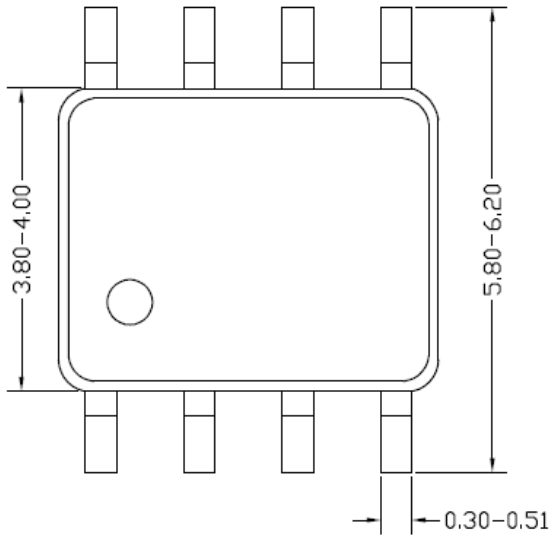

Top view

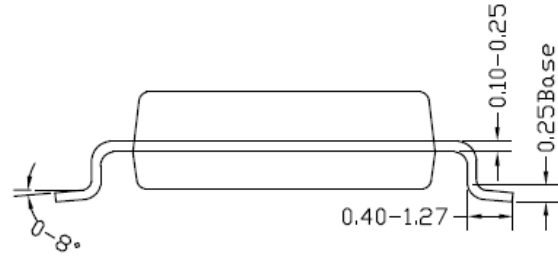

Side view

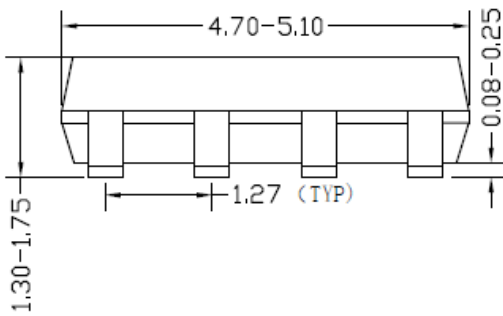

Front view

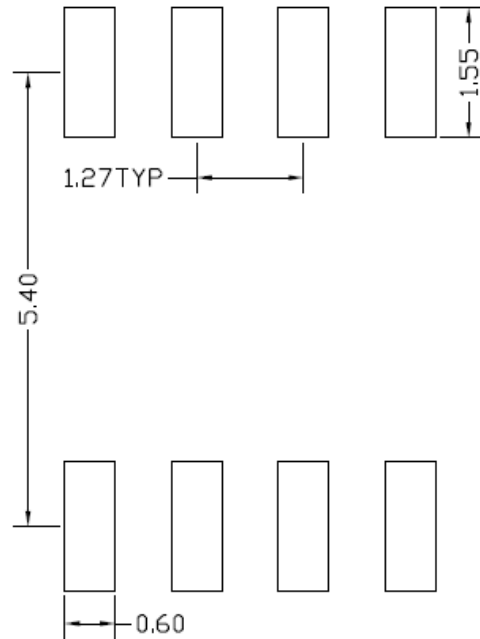

**Recommended Pad Layout
(Reference only)**

Notes: All dimension in millimeter and exclude mold flash & metal burr.

Taping & Reel Specification

1. Taping orientation for packages (SO8)

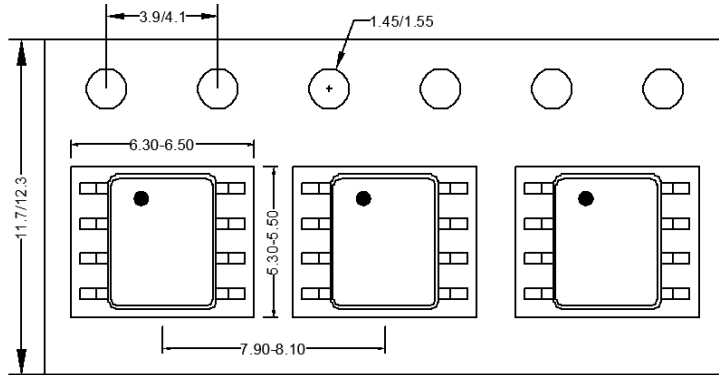

2. Carrier Tape & Reel specification for packages

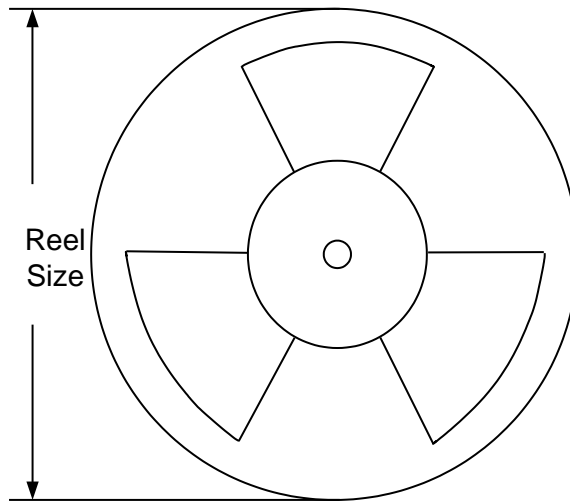

Package type	Tape width (mm)	Pocket pitch(mm)	Reel size (Inch)	Trailer length(mm)	Leader length (mm)	Qty per reel
SO8	12	8	13"	400	400	2500

Revision History

The revision history provided is for informational purpose only and is believed to be accurate, however, not warranted. Please make sure that you have the latest revision.

Date	Revision	Change
September 4, 2020	Revision 0.9	Initial Risk Production Release
September 4, 2021	Revision 1.0	Initial Production Release

IMPORTANT NOTICE

- 1. Right to make changes.** Silergy and its subsidiaries (hereafter Silergy) reserve the right to change any information published in this document, including but not limited to circuitry, specification and/or product design, manufacturing or descriptions, at any time and without notice. This document supersedes and replaces all information supplied prior to the publication hereof. Buyers should obtain the latest relevant information before placing orders and should verify that such information is current and complete. All semiconductor products are sold subject to Silergy's standard terms and conditions of sale.
- 2. Applications.** Application examples that are described herein for any of these products are for illustrative purposes only. Silergy makes no representation or warranty that such applications will be suitable for the specified use without further testing or modification. Buyers are responsible for the design and operation of their applications and products using Silergy products. Silergy or its subsidiaries assume no liability for any application assistance or designs of customer products. It is customer's sole responsibility to determine whether the Silergy product is suitable and fit for the customer's applications and products planned. To minimize the risks associated with customer's products and applications, customer should provide adequate design and operating safeguards. Customer represents and agrees that it has all the necessary expertise to create and implement safeguards which anticipate dangerous consequences of failures, monitor failures and their consequences, lessen the likelihood of failures that might cause harm and take appropriate remedial actions. Silergy assumes no liability related to any default, damage, costs or problem in the customer's applications or products, or the application or use by customer's third-party buyers. Customer will fully indemnify Silergy, its subsidiaries, and their representatives against any damages arising out of the use of any Silergy components in safety-critical applications. It is also buyers' sole responsibility to warrant and guarantee that any intellectual property rights of a third party are not infringed upon when integrating Silergy products into any application. Silergy assumes no responsibility for any said applications or for any use of any circuitry other than circuitry entirely embodied in a Silergy product.
- 3. Limited warranty and liability.** Information furnished by Silergy in this document is believed to be accurate and reliable. However, Silergy makes no representation or warranty, expressed or implied, as to the accuracy or completeness of such information and shall have no liability for the consequences of use of such information. In no event shall Silergy be liable for any indirect, incidental, punitive, special or consequential damages, including but not limited to lost profits, lost savings, business interruption, costs related to the removal or replacement of any products or rework charges, whether or not such damages are based on tort or negligence, warranty, breach of contract or any other legal theory. Notwithstanding any damages that customer might incur for any reason whatsoever, Silergy' aggregate and cumulative liability towards customer for the products described herein shall be limited in accordance with the Standard Terms and Conditions of Sale of Silergy.
- 4. Suitability for use.** Customer acknowledges and agrees that it is solely responsible for compliance with all legal, regulatory and safety-related requirements concerning its products, and any use of Silergy components in its applications, notwithstanding any applications-related information or support that may be provided by Silergy. Silergy products are not designed, authorized or warranted to be suitable for use in life support, life-critical or safety-critical systems or equipment, nor in applications where failure or malfunction of an Silergy product can reasonably be expected to result in personal injury, death or severe property or environmental damage. Silergy assumes no liability for inclusion and/or use of Silergy products in such equipment or applications and therefore such inclusion and/or use is at the customer's own risk.
- 5. Terms and conditions of commercial sale.** Silergy products are sold subject to the standard terms and conditions of commercial sale, as published at <http://www.silergy.com/stdterms>, unless otherwise agreed in a valid written individual agreement specifically agreed to in writing by an authorized officer of Silergy. In case an individual agreement is concluded only the terms and conditions of the respective agreement shall apply. Silergy hereby expressly objects to and denies the application of any customer's general terms and conditions with regard to the purchase of Silergy products by the customer.
- 6. No offer to sell or license.** Nothing in this document may be interpreted or construed as an offer to sell products that is open for acceptance or the grant, conveyance or implication of any license under any copyrights, patents or other industrial or intellectual property rights. Silergy makes no representation or warranty that any license, either express or implied, is granted under any patent right, copyright, mask work right, or other intellectual property right. Information published by Silergy regarding third-party products or services does not constitute a license to use such products or services or a warranty or endorsement thereof. Use of such information may require a license from a third party under the patents or other intellectual property of the third party, or a license from Silergy under the patents or other intellectual property of Silergy.

For more information, please visit: www.silergy.com

© 2021 Silergy Corp.

All Rights Reserved.