

General Description

The SQ52132D is a 100V/V fixed-gain current sense amplifier featuring high accuracy, high bandwidth, and a wide common-mode voltage range from -4V to 80V, independent of the supply voltage. This wide common-mode voltage facilitates use in high-side current-sense applications, and its capability to handle negative common-mode voltages enables operation in low-side current-sense applications, including those below ground.

The SQ52132D features low offset voltage, minimal gain error, and high DC Common Mode Rejection Ratio (CMRR), enabling precise current measurements. With a bandwidth of 1MHz and an AC CMRR of 80dB at 50kHz, the device is suitable for high-speed applications.

The supply voltage range of the SQ52132D is 2.7V to 20V, and the device draws 1.3mA quiescent current. It is available in a SOT23-5 package and is specified for the extended industrial temperature range of -40°C to 125°C.

Other Gain versions of the product, namely SQ52132C (50V/V) and SQ52132E (200V/V), will be launched in the future.

Features

- Supply Voltage Range: 2.7V to 20V
- Quiescent Current: 1.3mA (Typ)
- Wide Common-Mode Range:
 - Operational Voltage: -4V to 80V
 - Survival Voltage: -6V to +90V
- Excellent CMRR:
 - DC CMRR: 126dB (Min)
 - AC CMRR: 80dB (Typ) at 50kHz
- High-Accuracy:
 - Offset Voltage: $\pm 20\mu\text{V}$ (Typ)
 - Offset Voltage Drift: $\pm 0.1\mu\text{V}/^\circ\text{C}$ (Typ)
 - Gain Error: $\pm 0.2\%$ (Max)
 - Gain Error Drift: $\pm 10\text{ppm}/^\circ\text{C}$ (Max)
- Fixed Gain: 100V/V
- High Bandwidth: 1MHz
- Slew Rate: 10V/ μs

Applications

- Overcurrent Protection
- Servers
- Power Supplies
- Telecom Equipment
- Battery Management Systems (BMS)

Typical Application

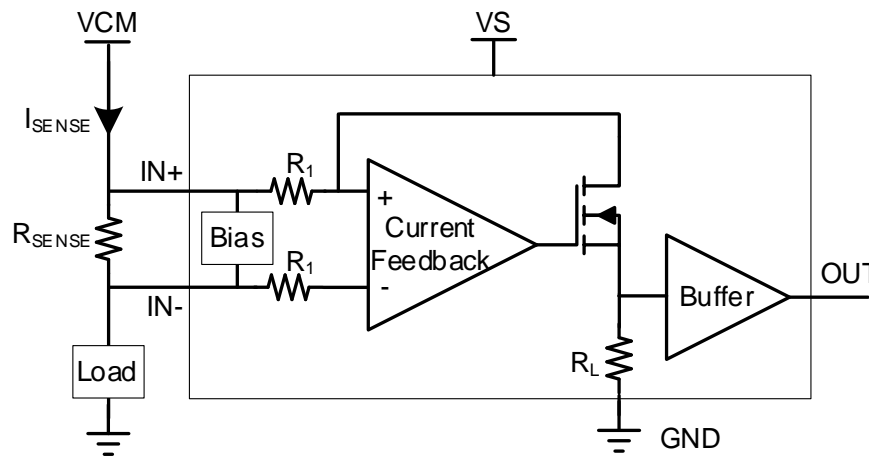

Figure 1. Typical Application Circuit

Ordering Information

Ordering Part Number	Package Type	Top Mark	Gain
SQ52132CAAT*	SOT23-5	HBM _{xyz}	50V/V
SQ52132DAAT	SOT23-5	HBN _{xyz}	100V/V
SQ52132EAAT*	SOT23-5	HBQ _{xyz}	200V/V

Device code: HBM, HBN, HBQ

x=year code, y=week code, z=lot number code.

*Future product. Specifications subject to change

Pinout (Top View)

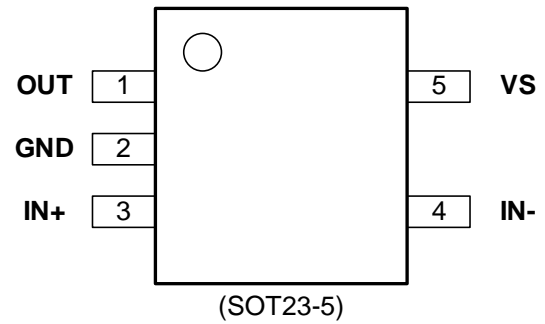

Pin Description

Pin No	Pin Name	Pin Description
1	OUT	Output voltage.
2	GND	Ground.
3	IN+	Shunt resistor positive sense input.
4	IN-	Shunt resistor negative sense input.
5	VS	Power supply.

Absolute Maximum Ratings

Parameter (Note 1)	Min	Max	Unit
VS	-0.3	21	V
IN+ - IN- (Differential)	-12	12	
IN+, IN- (Common-Mode)	-6	90	
Output	GND-0.3	VS+0.3	
Operating Free-Air Temperature	-55	150	°C
Junction Temperature Range	-40	150	
Storage Temperature Range	-65	150	
ESD: HBM (Human Body Model)	± 2000		V
ESD: CDM (Charged Device Model)	± 1000		V

Thermal Information

Parameter (Note 2)	Max	Unit
θ_{JA} Junction-to-Ambient Thermal Resistance	155	°C/W
θ_{JC} Junction-to-Case Thermal Resistance (top)	50	
PD Power Dissipation $T_A = 25^\circ\text{C}$	0.65	W

Recommended Operating Conditions

Parameter (Note 3)	Min	Max	Unit
VS	2.7	20	V
Common Mode, IN+, IN-	-4	80	
Operation Temperature	-40	125	°C

Electrical Characteristics

$T_A = 25^\circ\text{C}$, $V_S = 5\text{V}$, $V_{\text{SENSE}} = V_{\text{IN}+} - V_{\text{IN}-} = 5\text{mV}$, $V_{\text{CM}} = V_{\text{IN}+} = 48\text{V}$, unless otherwise noted. (Note 4)

Parameter	Symbol	Conditions	Min	Typ	Max	Units
Input						
Common Mode Input Voltage	V_{CM}	$T_A = -40^\circ\text{C}$ to $+125^\circ\text{C}$	-4		80	V
Common Mode Rejection Ratio, RTI (Note 6)	CMRR	$V_{\text{IN}+} = -4\text{V}$ to 80V , $T_A = -40^\circ\text{C}$ to $+125^\circ\text{C}$	114	123		dB
		$V_{\text{IN}+} = 5\text{V}$ to 80V , $T_A = -40^\circ\text{C}$ to $+125^\circ\text{C}$	126	130		
		$f = 50\text{ kHz}$ (Note 5)		80		
Offset Voltage, RTI	V_{OS}			± 20	± 65	μV
Offset Voltage Drift	dV_{OS}/dT	$T_A = -40^\circ\text{C}$ to $+125^\circ\text{C}$		± 0.1	± 0.5	$\mu\text{V}/^\circ\text{C}$
Power Supply Rejection Ratio	PSRR	$V_S = 2.7\text{V}$ to 20V , $T_A = -40^\circ\text{C}$ to $+125^\circ\text{C}$		± 1.5	± 6	$\mu\text{V}/\text{V}$
Input Bias Current	I_B	I_{B+} , I_{B-} , $V_{\text{SENSE}} = 0\text{mV}$		25	30	μA
Output						
Gain	G			100		V/V
Gain Error		$V_{\text{GND}} + 50\text{mV} \leq V_{\text{OUT}} \leq V_S - 200\text{mV}$		± 0.05	± 0.2	%
		$T_A = -40^\circ\text{C}$ to 125°C		± 2	± 10	ppm/ $^\circ\text{C}$
Nonlinearity Error (Note 5)		$V_{\text{GND}} + 10\text{mV} \leq V_{\text{OUT}} \leq V_S - 200\text{mV}$		± 0.01		%
Maximum Capacitive Load (Note 5)		No sustained oscillation		1		nF
Voltage Output						
Swing to V_S Power Supply Rail		$R_L = 10\text{k}\Omega$ to GND, $T_A = -40^\circ\text{C}$ to $+125^\circ\text{C}$		$V_S - 0.07$	$V_S - 0.15$	V
Swing to GND		$R_L = 10\text{k}\Omega$ to GND, $V_{\text{SENSE}} = 0\text{mV}$ $T_A = -40^\circ\text{C}$ to $+125^\circ\text{C}$		$V_{\text{GND}} + 5$	$V_{\text{GND}} + 20$	mV
Frequency Response (Note 5)						
Bandwidth	BW	$V_{\text{SENSE}} = 40\text{mV}$		1000		kHz
Slew Rate	SR			10		V/ μs
Settling Time		$V_{\text{OUT}} = 4\text{V} \pm 0.1\text{V}$ step, output settles to 0.5% of final value		1.5		μs
		$V_{\text{OUT}} = 4\text{V} \pm 0.1\text{V}$ step, output settles to 1% of final value		1.2		
		$V_{\text{OUT}} = 4\text{V} \pm 0.1\text{V}$ step, output settles to 5% of final value		0.6		
Noise, RTI (Note 5)						
Voltage Noise Density				50		nV/ $\sqrt{\text{Hz}}$
Power Supply						
Operating Supply Range	V_S	$T_A = -40^\circ\text{C}$ to $+125^\circ\text{C}$	2.7		20	V
Quiescent Current	I_Q	$T_A = -40^\circ\text{C}$ to $+125^\circ\text{C}$		1.3	1.6	mA
					1.7	

Note 1: Stresses beyond the “Absolute Maximum Ratings” may cause permanent damage to the device. These are stress ratings only. Functional operation of the device at these or any other conditions beyond those indicated in the operational sections of the specification is not implied. Exposure to absolute maximum rating conditions for extended periods may affect device reliability.

Note 2: Package thermal resistance is measured with natural convection at $T_A = 25^\circ\text{C}$, θ_{JA} is measured on a low effective two-layer test board per JESD51-3. $\theta_{JC(\text{top})}$ is measured in accordance with JESD51-14.

Note 3: The device is not guaranteed to function outside its operating conditions.

Note 4: Unless otherwise stated, limits are 100% production tested at $T_A \approx T_J = 25^\circ\text{C}$. Limits over the operating temperature range (see recommended operating conditions) and relevant voltage range(s) are guaranteed by design, test, or statistical correlation.

Note 5: Guaranteed by design or statistical correlation and not production tested.

Note 6: RTI = Referred to Input.

Typical Performance Characteristics

($T_A = 25^\circ\text{C}$, $V_S = 5\text{V}$, $V_{\text{SENSE}} = V_{\text{IN}+} - V_{\text{IN}-} = 5\text{mV}$, $V_{\text{CM}} = V_{\text{IN}+} = 48\text{V}$, unless otherwise noted.)

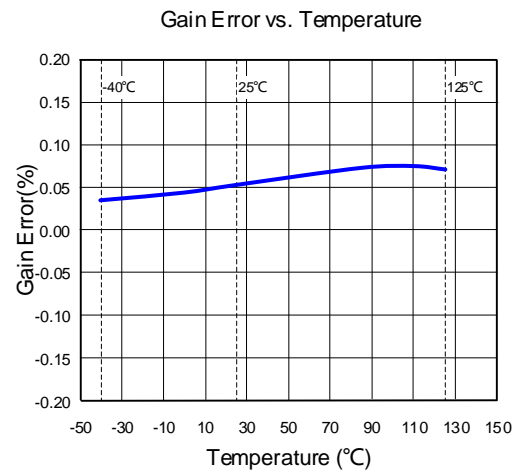
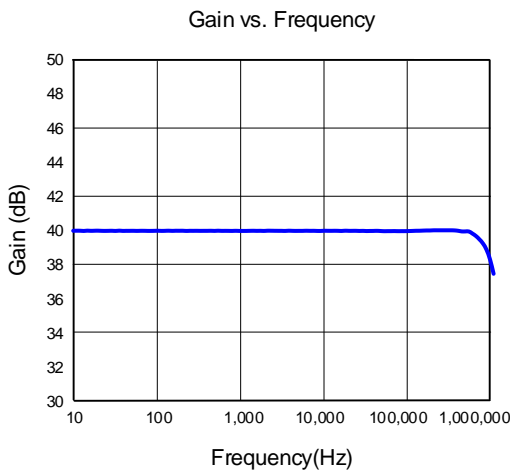
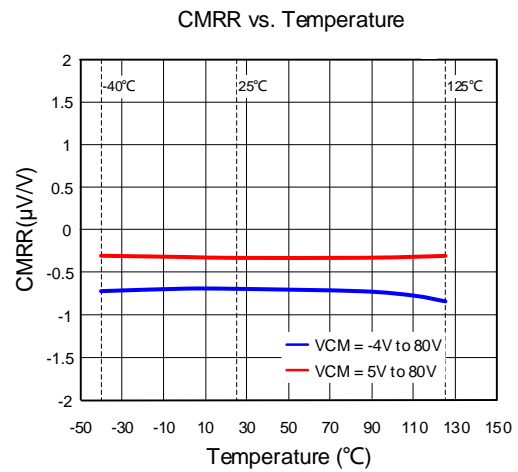
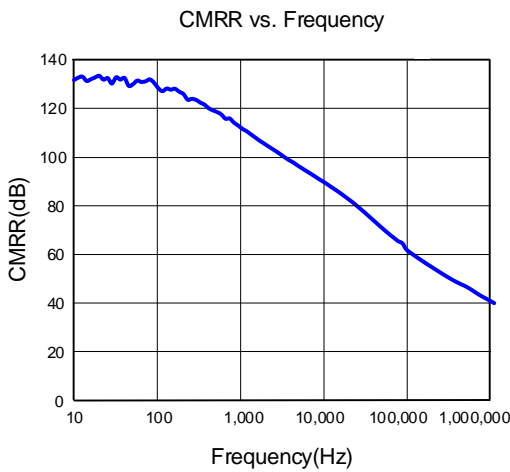
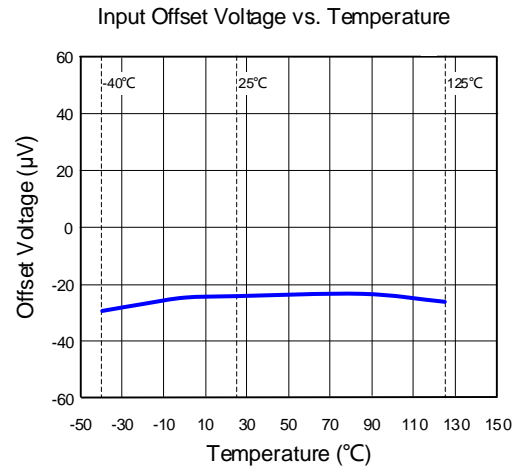
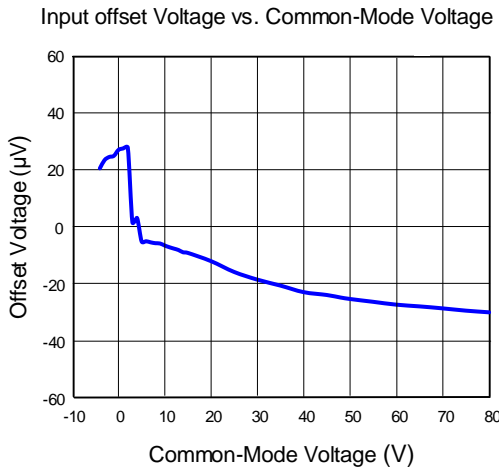

Input Bias Current vs. Common-Mode Voltage

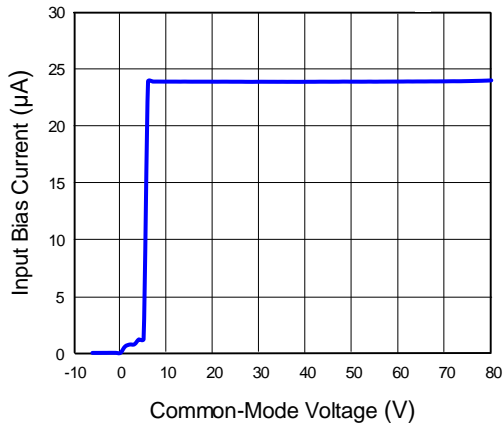

Input Bias Current vs. Temperature

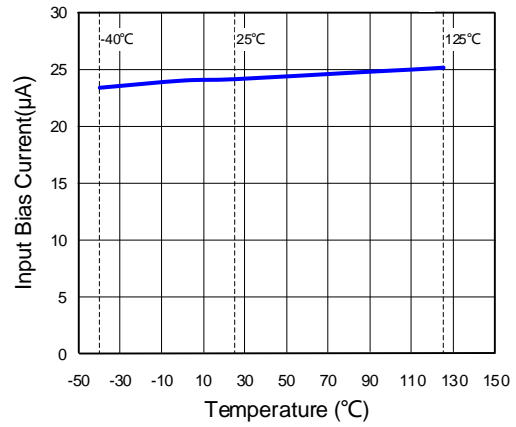

Input Bias Current vs. V_{SENSE}

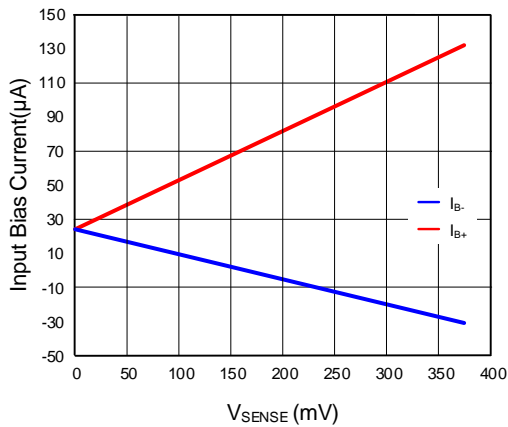

Quiescent Current vs. Supply Voltage

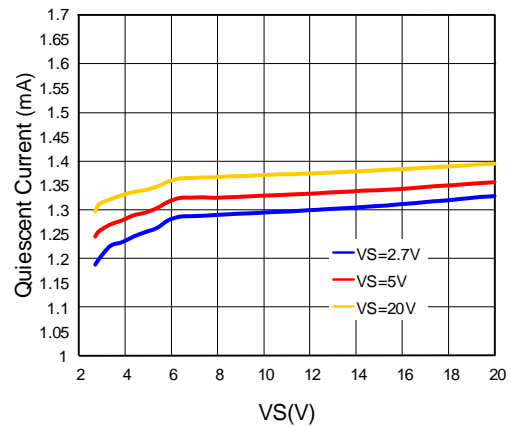

Quiescent Current vs. Temperature

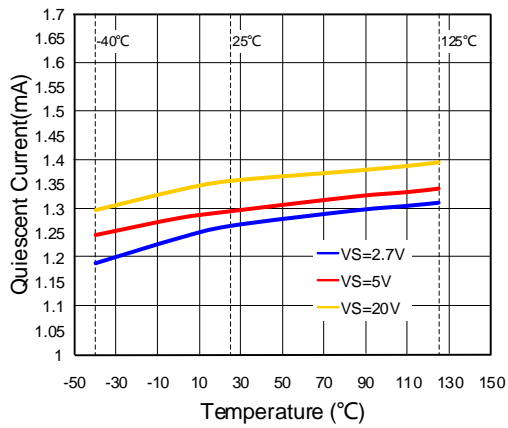

Output Voltage vs. Output Current

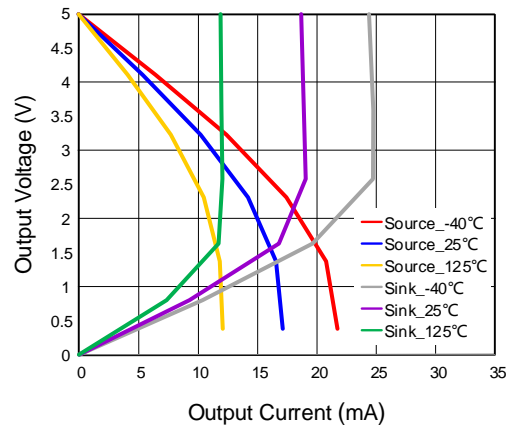

Application Information

The SQ52132D is a fixed gain, high accuracy current sense amplifier that can sense current by amplifying the differential voltage across an external shunt resistor to create an output voltage. Its wide common-mode range and high bandwidth enable its use in high and low-side applications where high-speed and high-precision current measurements are required.

Unidirectional Current Sense Operation

The SQ52132D is a unidirectional current sense device. It measures the voltage developed across a current sense resistor. The transfer function of the SQ52132D is:

$$OUT = Gain \times V_{sense}$$

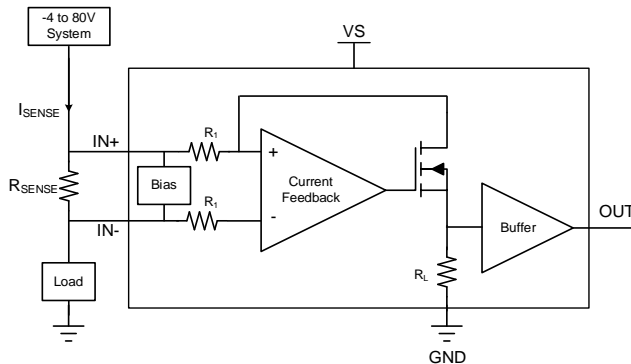

Figure 2. Unidirectional Application

Figure 2 shows the application circuit diagram of SQ52132D. When the input signal increases, the output voltage will increase. Due to the unidirectional current sense, only current flowing from the IN+ terminal of the sense resistor to the IN- terminal can be measured.

The device offers a good linearity when the output swing is limited to the recommended range. The maximum negative output swing is 20mV, and the positive output swing is $V_S - 0.15V$. Ensure that the differential input voltage is higher than 0.2mV and less than $(V_S - 0.15) / 100$ to bring the output into the linear range of the device.

Input Filtering

To reduce the influence of noise on the sensed power rail and improve the system signal-to-noise ratio (SNR), it is recommended to place an RC filter at the input pins, as shown in Figure 3.

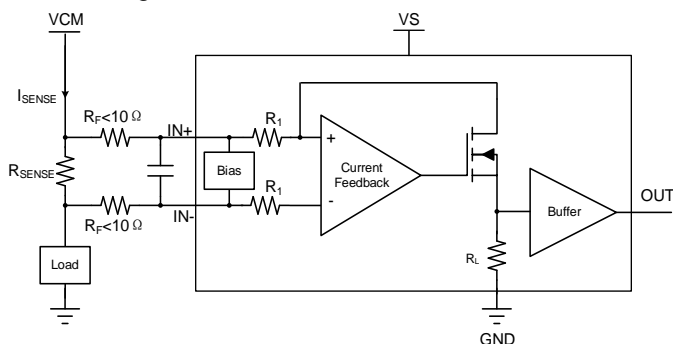

Figure 3. Filter at Input Pins

Adding external series resistors may add additional errors in the measurement, so using a low value for the resistors is recommended.

When differential voltages are applied between the input pins of the SQ52132D, an internal bias network makes a mismatch in the input bias currents. Using external series filter resistors in the circuit results in a voltage drop mismatch across these resistors. This mismatch yields a differential-error voltage, which offsets the voltage across the shunt resistor, altering the voltage at the device input pins. Without additional series resistance, the mismatch of input bias current has little effect on device operation. To reduce the impact on accuracy, the value of these series resistors should be less than 10Ω.

The amount of error that these external filter resistors add to the measurement can be calculated as follows:

$$Gain\ error = \left(\frac{7100}{7100 + R_F + \frac{14200R_F}{R_B}} - 1 \right) \times 100\%$$

In the equation, R_B is an internal bias resistor with a value of $6.8k\Omega \pm 20\%$. An $R_F = 10\Omega$ for external series resistance will result in a gain error range from -0.385% to -0.506%.

Selecting R_SENSE

The value of the current sense resistor is influenced by the maximum measured current, the range of the differential input voltage, and the power supply voltage. Additionally, the output swing and power dissipation also impact the resistor value. The presence of offset voltage, gain error, and other parameters in the current sense amplifier necessitates choosing the largest possible sense resistor to maximize the differential signal value, reduce detection errors, and enhance measurement accuracy. However, due to factors such as power dissipation and voltage swing, the size of the resistor value will be subject to certain limitations.

According to the Electrical Characteristics of the SQ52132D, the maximum value of the negative output swing is 20mV, and the maximum value of the positive output swing is $V_S - 0.15V$. Given that the maximum value of the measured current is I_{sense} , the value of the sense resistor, R_{sense} , should be within the range of $0.02V / (100 \times I_{sense})$ and $(V_S - 0.15V) / (100 \times I_{sense})$.

Given that the maximum value of the negative output swing is only 20mV, corresponding to an input differential voltage of just 0.2mV, practical applications typically require higher input differential voltages. Therefore, only the effect of the positive swing should be considered when determining the value of the sense resistor in most applications.



I_{SENSE} and R_{SENSE} Design Recommendations

Tables 1 and 2 show the recommended sense resistor values for different measured current ranges and the maximum power loss for application design reference.

Table 1. I_{SENSE} and R_{SENSE} Design Recommendations (V_S=5V)

I _{SENSE} Range	Recommended R _{SENSE}	R _{SENSE} Power Dissipation Maximum
	V _S =5V	
0A-1A	48mΩ	48mW
0A-2A	24mΩ	96mW
0A-3A	16mΩ	144mW
0A-5A	9.6mΩ	240mW
0A-10A	4.8mΩ	480mW

Table 2. I_{SENSE} and R_{SENSE} Design Recommendations (V_S=20V)

I _{SENSE} Range	Recommended R _{SENSE}	R _{SENSE} Power Dissipation Maximum
	V _S =20V	
0A-1A	198mΩ	198mW
0A-2A	99mΩ	396mW
0A-3A	66mΩ	594mW
0A-5A	39.6mΩ	990mW
0A-10A	19.8mΩ	1980mW

Application Schematic

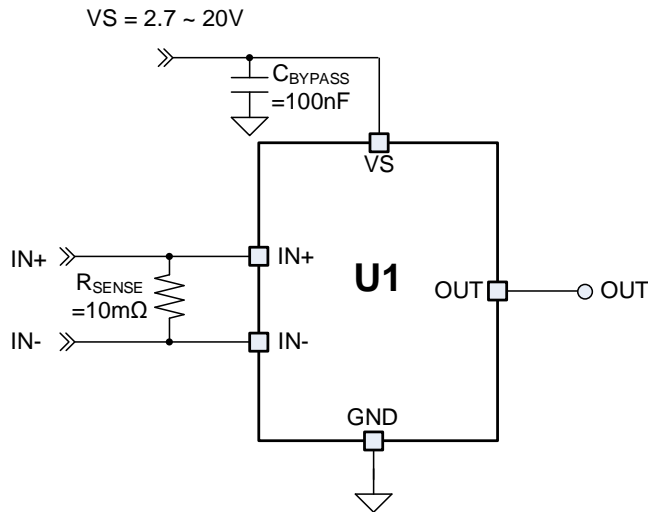

Figure 4. Schematic Diagram

BOM List

Designator	Description	Part Number	MFR
C _{BYPASS}	100nF/50V/X7R, 0603	GCJ188R71H104KA12D	muRata
R _{SENSE}	10mΩ/1W, 1%, 2512	RL2512FK-070R01L	YAGEO

PCB Layout Guide

For optimal design, follow these PCB layout guidelines:

1. Use a Kelvin connection to connect the input pins to the current-sensing resistor R_{SENSE}. Due to the low resistance values of R_{SENSE}, poor PCB routing often leads to additional parasitic resistance between input pins, resulting in additional errors. This connection method ensures that only R_{SENSE} impedance is detected between the input pins. Minimize the loop formed by these connections.
2. Place a bypass capacitor (a 0.1μF MLCC is recommended) as close as possible to the VS and GND pins.

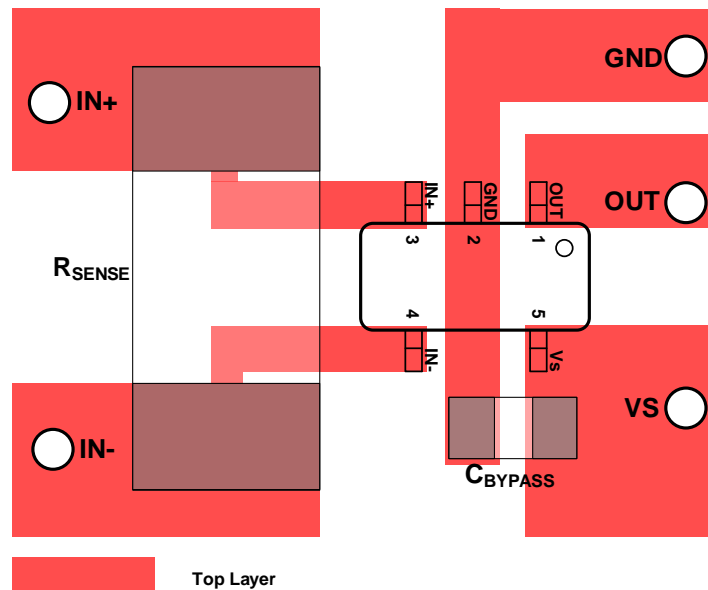
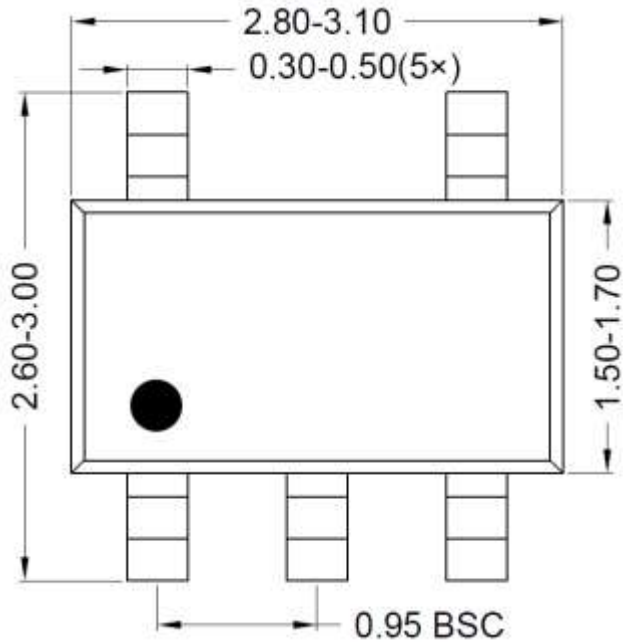
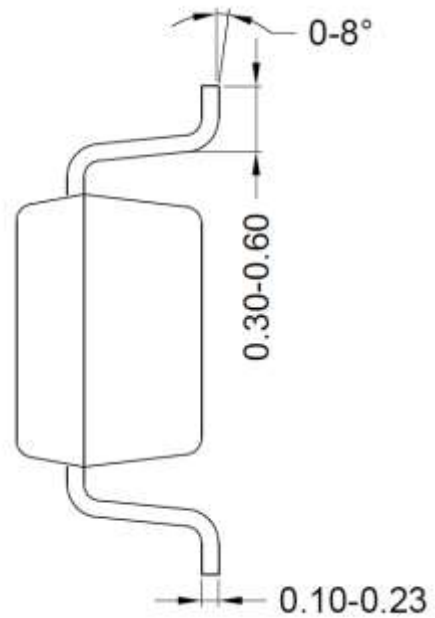

Figure 5. Recommended Layout

SOT23-5 Package Outline Drawing



Top View



Side View

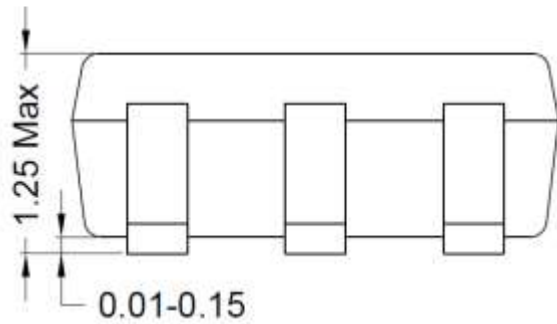

Front View

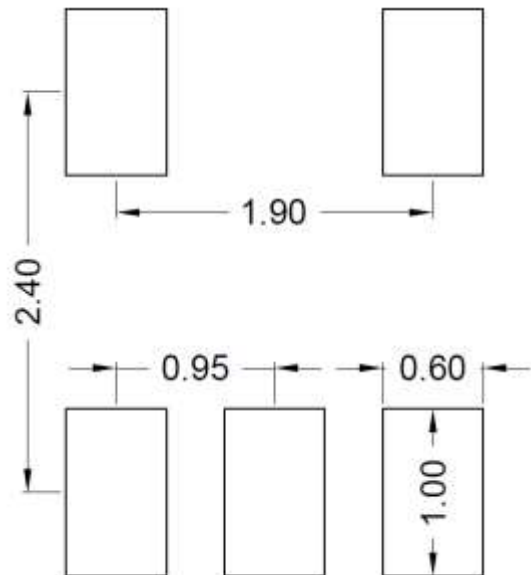

**Recommended PCB Layout
(Reference Only)**

Note: All dimensions are in millimeters and exclude mold flash & metal burr.

Tape and Reel Information

SOT23-5 Taping Orientation

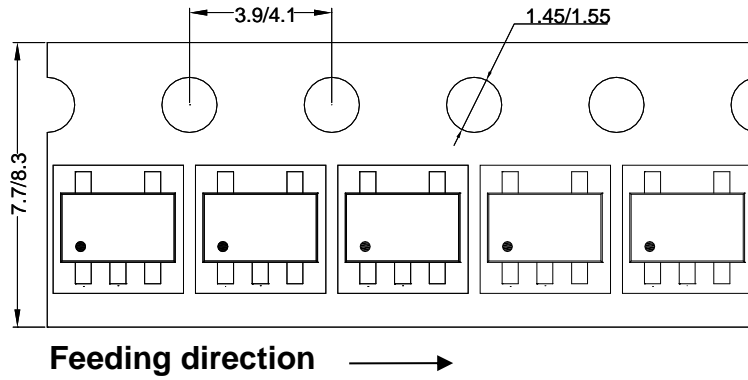

Carrier Tape and Reel Specification for Packages

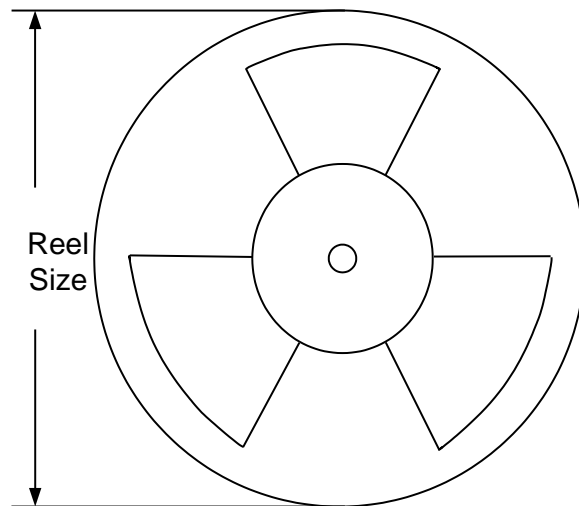

Package type	Tape width (mm)	Pocket pitch (mm)	Reel size (Inch)	Reel width (mm)	Trailer * length (mm)	Leader * length (mm)	Qty per reel (pcs)
SOT23-5	8	4	7"	8.4	280	160	3000



Revision History

The revision history provided is for informational purposes only and is believed to be accurate; however, not warranted. Please make sure that you have the latest revision.

Date	Revision	Change
May. 31, 2024	Revision 1.0	Initial Release



IMPORTANT NOTICE

1. **Right to make changes.** Silergy and its subsidiaries (hereafter Silergy) reserve the right to change any information published in this document, including but not limited to circuitry, specification and/or product design, manufacturing or descriptions, at any time and without notice. This document supersedes and replaces all information supplied prior to the publication hereof. Buyers should obtain the latest relevant information before placing orders and should verify that such information is current and complete. All semiconductor products are sold subject to Silergy's standard terms and conditions of sale.

2. **Applications.** Application examples that are described herein for any of these products are for illustrative purposes only. Silergy makes no representation or warranty that such applications will be suitable for the specified use without further testing or modification. Buyers are responsible for the design and operation of their applications and products using Silergy products. Silergy or its subsidiaries assume no liability for any application assistance or designs of customer products. It is customer's sole responsibility to determine whether the Silergy product is suitable and fit for the customer's applications and products planned. To minimize the risks associated with customer's products and applications, customer should provide adequate design and operating safeguards. Customer represents and agrees that it has all the necessary expertise to create and implement safeguards which anticipate dangerous consequences of failures, monitor failures and their consequences, lessen the likelihood of failures that might cause harm and take appropriate remedial actions. Silergy assumes no liability related to any default, damage, costs or problem in the customer's applications or products, or the application or use by customer's third-party buyers. Customer will fully indemnify Silergy, its subsidiaries, and their representatives against any damages arising out of the use of any Silergy components in safety-critical applications. It is also buyers' sole responsibility to warrant and guarantee that any intellectual property rights of a third party are not infringed upon when integrating Silergy products into any application. Silergy assumes no responsibility for any said applications or for any use of any circuitry other than circuitry entirely embodied in a Silergy product.

3. **Limited warranty and liability.** Information furnished by Silergy in this document is believed to be accurate and reliable. However, Silergy makes no representation or warranty, expressed or implied, as to the accuracy or completeness of such information and shall have no liability for the consequences of use of such information. In no event shall Silergy be liable for any indirect, incidental, punitive, special or consequential damages, including but not limited to lost profits, lost savings, business interruption, costs related to the removal or replacement of any products or rework charges, whether or not such damages are based on tort or negligence, warranty, breach of contract or any other legal theory. Notwithstanding any damages that customer might incur for any reason whatsoever, Silergy' aggregate and cumulative liability towards customer for the products described herein shall be limited in accordance with the Standard Terms and Conditions of Sale of Silergy.

4. **Suitability for use.** Customer acknowledges and agrees that it is solely responsible for compliance with all legal, regulatory and safety-related requirements concerning its products, and any use of Silergy components in its applications, notwithstanding any applications-related information or support that may be provided by Silergy. Silergy products are not designed, authorized or warranted to be suitable for use in life support, life-critical or safety-critical systems or equipment, nor in applications where failure or malfunction of a Silergy product can reasonably be expected to result in personal injury, death or severe property or environmental damage. Silergy assumes no liability for inclusion and/or use of Silergy products in such equipment or applications and therefore such inclusion and/or use is at the customer's own risk.

5. **Terms and conditions of commercial sale.** Silergy products are sold subject to the standard terms and conditions of commercial sale, as published at <https://www.silergy.com>, unless otherwise agreed in a valid written individual agreement specifically agreed to in writing by an authorized officer of Silergy. In case an individual agreement is concluded only the terms and conditions of the respective agreement shall apply. Silergy hereby expressly objects to and denies the application of any customer's general terms and conditions with regard to the purchase of Silergy products by the customer.

6. **No offer to sell or license.** Nothing in this document may be interpreted or construed as an offer to sell products that is open for acceptance or the grant, conveyance or implication of any license under any copyrights, patents or other industrial or intellectual property rights. Silergy makes no representation or warranty that any license, either express or implied, is granted under any patent right, copyright, mask work right, or other intellectual property right. Information published by Silergy regarding third-party products or services does not constitute a license to use such products or services or a warranty or endorsement thereof. Use of such information may require a license from a third party under the patents or other intellectual property of the third party, or a license from Silergy under the patents or other intellectual property of Silergy.

For more information, please visit: www.silergy.com

© 2024 Silergy Corp.

All Rights Reserved.