

General Description

The SQ52131x is fixed-gain, high-speed, high precision, high-side or low-side bidirectional current-sense amplifier with a voltage output. It operates over a wide common-mode voltage range of -4V to 80V, independent of the supply voltage. The negative common-mode voltage allows the device to operate below ground. Enhanced PWM rejection makes the SQ52131x suitable for current sensing and overcurrent protection in switching systems with large common-mode voltage transients (high $\Delta V/\Delta t$) at the device's inputs, such as motor control, DC/DC converters, and battery management systems.

The SQ52131x utilizes zero-drift architecture. Its low input offset voltage (V_{OS}) enables precise measurement of low-voltage drops. The device operates from a single 2.7V to 5.5V power supply and draws 1.8mA (typ.) quiescent current.

The device is available in TSSOP8 and SOP8 packages and is specified over the extended industrial temperature range of -40°C to 125°C.

Features

- -4V to 80V Wide Common-Mode Operation Range Voltage-Output, Current-Sense Amplifier
- Enhanced PWM Rejection
- Excellent CMRR:
 - 132dB DC CMRR
 - 93dB AC CMRR at 50kHz
- High Accuracy:
 - Gain Error: 0.15% (Max)
 - Gain Drift: 2.5ppm/°C (Max)
- Low Offset Voltage:
 - Offset Voltage: $\pm 22\mu V$ (Max)
 - Offset Drift: 250nV/°C (Max)
- High Bandwidth: 550kHz
- Fixed Gain:
 - 50V/V (SQ52131CHMP/SQ52131FAP)
 - 200V/V (SQ52131EFAP)
- Quiescent Current: 2.4mA (Max)
- Package: TSSOP8/ SOP8
- MSL Rating: MSL1(TSSOP8)/MSL3(SOP8)

Applications

- Motor Controls
- DC/DC Converters
- Power Management
- Battery Management Systems (BMS)
- Pressure Regulators
- Telecom Equipmen

Typical Application and Block Diagram

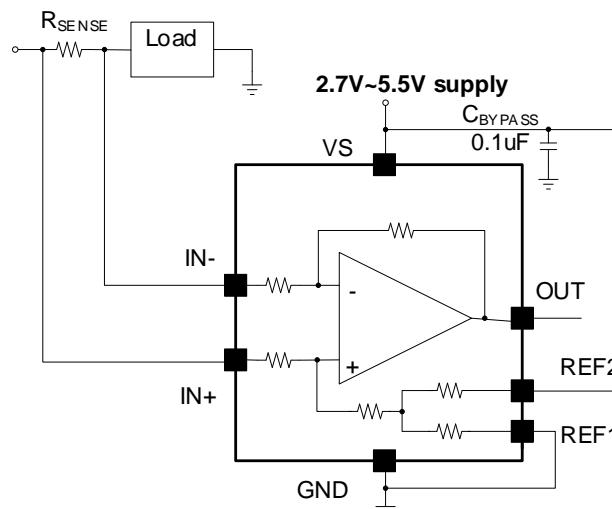

Figure 1. Typical Application Circuit

Ordering Information

Ordering Part Number	Package Type	Top Mark	Gain
SQ52131CHMP	TSSOP8	KRBxyz	50V/V
SQ52131FAP	SOP8	GFGxyz	50V/V
SQ52131EFAP	SOP8	KRDxyz	200V/V

x=year code, y=week code, z= lot number code.

Pinout (Top View)

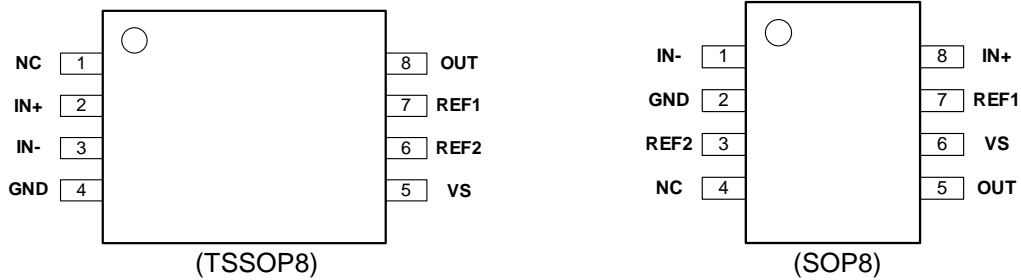

Pin Description

Pin Name	Pin No.		Pin Description
	TSSOP8	SOP8	
NC	1	4	Reserved. Connect to ground.
IN+	2	8	Positive input of current-sense amplifier. Connect to the high-side of the current-sense resistor.
IN-	3	1	Negative input of current-sense amplifier. Connect to the low-side of the current-sense resistor.
GND	4	2	Ground.
VS	5	6	Power supply. 2.7V to 5.5V.
REF2	6	3	Reference 2 voltage. Connect to 0V to VS.
REF1	7	7	Reference 1 voltage. Connect to 0V to VS.
OUT	8	5	Output voltage.

Absolute Maximum Ratings

Parameter (Note 1)	Min	Max	Unit
VS	-0.3	6	V
IN+ - IN- (Differential)	-80	80	
IN+, IN- (Common mode)	-6	90	
OUT	GND-0.3	VS+0.3V	
REF1, REF2, NC	GND-0.3	VS+0.3V	
Operating Free-Air Temperature	-55	150	°C
Junction Temperature, Operating	-40	150	
Storage Temperature	-65	150	
ESD: HBM (Human Body Model)	± 2000		V
ESD: CDM (Charged Device Model)	± 1000		V

Thermal Information

Parameter (Note 2)	TSSOP8	SOP8	Unit
θ_{JA} Junction-to-Ambient Thermal Resistance	190	114	°C/W
θ_{JC} Junction-to-Case Thermal Resistance	38	37	
P_D Power Dissipation $T_A = 25^\circ\text{C}$	0.53	0.88	W

Recommended Operating Conditions

Parameter (Note 3)	Min	Max	Unit
VS	2.7	5.5	V
Common Mode, IN+, IN-	-4	80	
Operating Free-Air Temperature	-40	125	°C

Electrical Characteristics

$T_A=25^{\circ}\text{C}$, $V_S=5\text{V}$, $V_{\text{SENSE}}=V_{\text{IN}+}-V_{\text{IN}-}$, $V_{\text{CM}}=12\text{V}$, and $V_{\text{REF1}}=V_{\text{REF2}}=V_S/2$, unless otherwise noted. (Note 4)

Parameter	Symbol	Conditions	Min	Typ	Max	Units
Input						
Common-Mode Input Voltage	V_{CM}		-4		80	V
Common-Mode Rejection Ratio	CMRR	$V_{\text{IN}+}=-4\text{V to }80\text{V}$, $V_{\text{SENSE}}=0\text{mV}$, $T_A=-40^{\circ}\text{C to }125^{\circ}\text{C}$	116	132		dB
		$f=50\text{ kHz}$ (Note 5)		93		
Offset Voltage, Input-Referred	V_{OS}	$V_{\text{SENSE}}=0\text{mV}$		± 5	± 22	μV
Offset Voltage Drift	dV_{OS}/dT	$V_{\text{SENSE}}=0\text{mV}$, $T_A=-40^{\circ}\text{C to }125^{\circ}\text{C}$		± 50	± 250	$\text{nV}/^{\circ}\text{C}$
Power-Supply Rejection Ratio	PSRR	$V_S=2.7\text{V to }5.5\text{V}$, $V_{\text{SENSE}}=0\text{mV}$, $T_A=-40^{\circ}\text{C to }125^{\circ}\text{C}$, SQ52131CHMP/SQ52131FAP		± 1	± 10	$\mu\text{V}/\text{V}$
		$V_S=2.7\text{V to }5.5\text{V}$, $V_{\text{SENSE}}=0\text{mV}$, $T_A=-40^{\circ}\text{C to }125^{\circ}\text{C}$, SQ52131EFAP		± 1	± 6	
Input Bias Current	I_B	I_{B+} , I_{B-} , $V_{\text{SENSE}}=0\text{mV}$		85		μA
Reference Input Range			0		V_S	V
Output						
Gain	G	SQ52131CHMP/SQ52131FAP		50		V/V
		SQ52131EFAP		200		
Gain Error		$V_{\text{GND}}+50\text{mV} \leq V_{\text{OUT}} \leq V_S-200\text{mV}$		$\pm 0.02\%$	$\pm 0.15\%$	
Gain Error Drift		$T_A=-40^{\circ}\text{C to }125^{\circ}\text{C}$		± 0.5	± 2.5	$\text{ppm}/^{\circ}\text{C}$
Non-Linearity Error (Note 5)		$V_{\text{GND}}+10\text{mV} \leq V_{\text{OUT}} \leq V_S-200\text{mV}$		$\pm 0.01\%$		
Reference Divider Accuracy		$V_{\text{OUT}}= (V_{\text{REF1}}-V_{\text{REF2}}) /2$ at $V_{\text{SENSE}}=0\text{mV}$ $T_A=-40^{\circ}\text{C to }125^{\circ}\text{C}$		0.02%	0.1%	
Reference Voltage Rejection Ratio (Input-Referred)	RVRR			2		$\mu\text{V}/\text{V}$
Maximum Capacitive Load (Note 5)		No sustained oscillation		2.2		nF
Voltage Output						
Swing to V_S Power-Supply Rail		$R_L=10\text{k}\Omega$ to GND, $T_A=-40^{\circ}\text{C to }125^{\circ}\text{C}$		$V_S-0.025$	$V_S-0.1$	V
Swing to GND		$R_L=10\text{k}\Omega$ to GND, $V_{\text{SENSE}}=0\text{mV}$ $V_{\text{REF1}}=V_{\text{REF2}}=0\text{V}$, $T_A=-40^{\circ}\text{C to }125^{\circ}\text{C}$		$V_{\text{GND}}+1$	$V_{\text{GND}}+10$	mV
Frequency Response (Note 5)						
Bandwidth	BW	-3-dB bandwidth		550		kHz
		2% THD+N		100		
Settling Time		Output settles to 0.5% of final value, SQ52131CHMP/SQ52131FAP		5.5		μs
		Output settles to 0.5% of final value, SQ52131EFAP		7		
Slew Rate	SR			2		$\text{V}/\mu\text{s}$
Noise (Input Referred) (Note 5)						
Voltage Noise Density				40		$\text{nV}/\sqrt{\text{Hz}}$
Power Supply						
Operating Voltage Range	V_S		2.7		5.5	V
Quiescent Current	I_Q	$V_{\text{SENSE}}=0\text{mV}$		1.8	2.4	mA
		I_Q vs temperature, $T_A=-40^{\circ}\text{C to }125^{\circ}\text{C}$			2.6	
Temperature Range						
Specified Range			-40		125	$^{\circ}\text{C}$



Note 1: Stresses beyond the “Absolute Maximum Ratings” may cause permanent damage to the device. These are stress ratings only. Functional operation of the device at these or any other conditions beyond those indicated in the operational sections of the specification is not implied. Exposure to absolute maximum rating conditions for extended periods may affect device reliability.

Note 2: Package thermal resistance is measured with natural convection at $T_A = 25^\circ\text{C}$ on an 8.5cm×8.5cm two-layer Silergy Evaluation Board.

Note 3: The device is not guaranteed to function outside its operating conditions.

Note 4: Unless otherwise stated, limits are 100% production tested at $T_A \approx T_J = 25^\circ\text{C}$. Limits over the operating temperature range (see recommended operating conditions) and relevant voltage range(s) are guaranteed by design, test, or statistical correlation.

Note 5: Guaranteed by design or statistical correlation and not production tested.

Typical Performance Characteristics

($T_A=25^\circ\text{C}$, $V_S=5\text{V}$, $V_{\text{SENSE}}=V_{\text{IN}+}-V_{\text{IN}-}$, $V_{\text{CM}}=12\text{V}$, and $V_{\text{REF1}}=V_{\text{REF2}}=V_S/2$, unless otherwise noted.)

Input Offset Voltage vs. Temperature

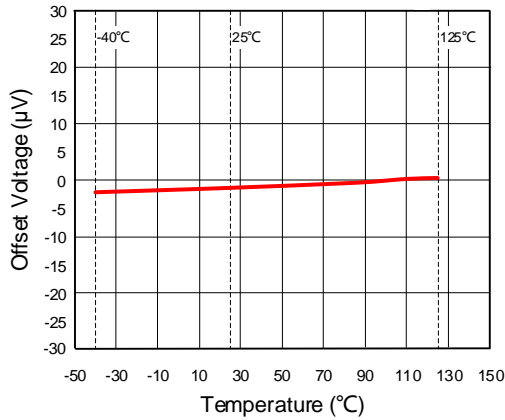

Common-Mode Rejection Ratio vs. Temperature

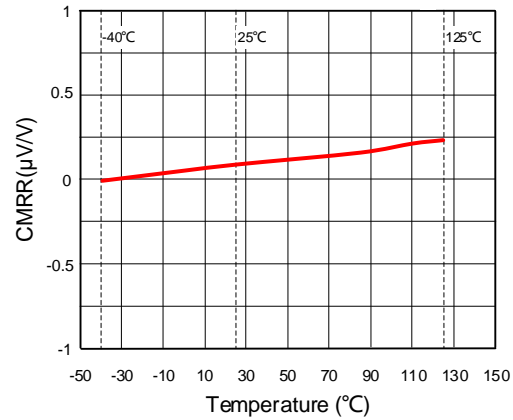

Gain Error vs. Temperature

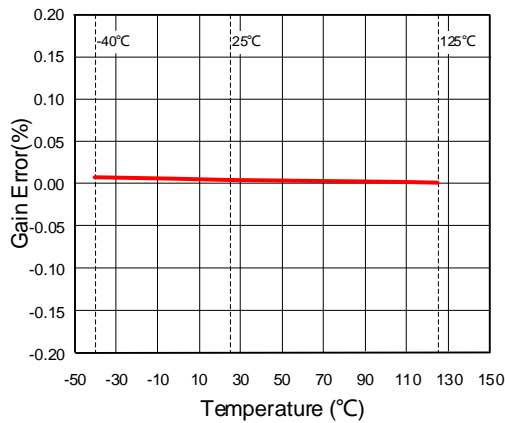

Input Bias Current vs. Temperature

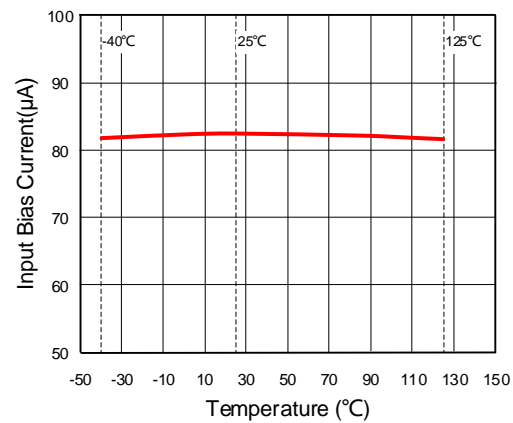

Quiescent Current vs. Temperature

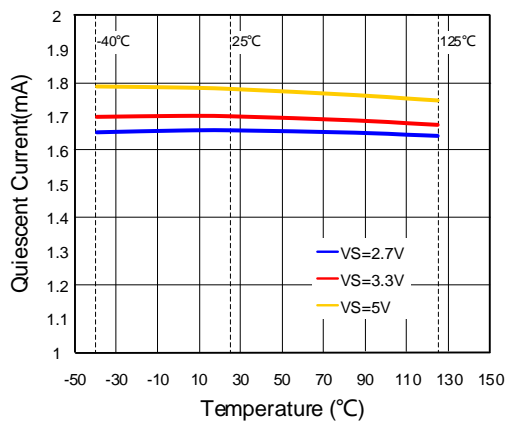

Input Bias Current vs. Common-Mode Voltage

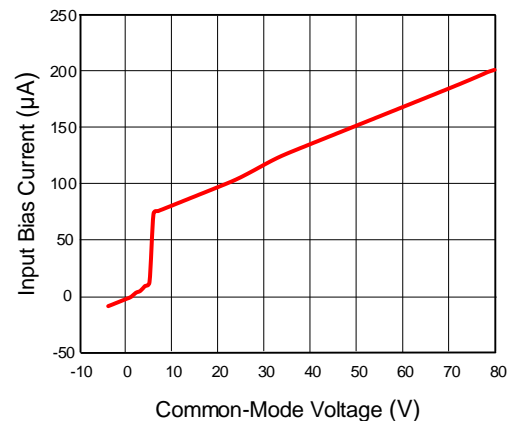

Input Bias Current vs. Differential Input Voltage

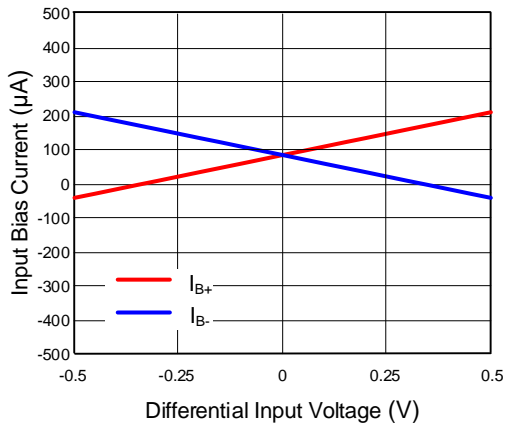

Common-Mode Rejection Ratio vs. Frequency

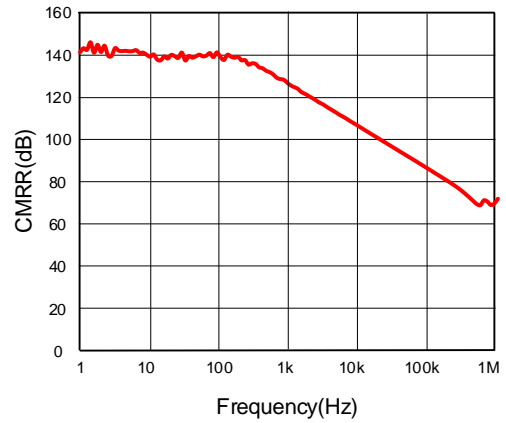

Power-Supply Rejection Ratio vs. Frequency

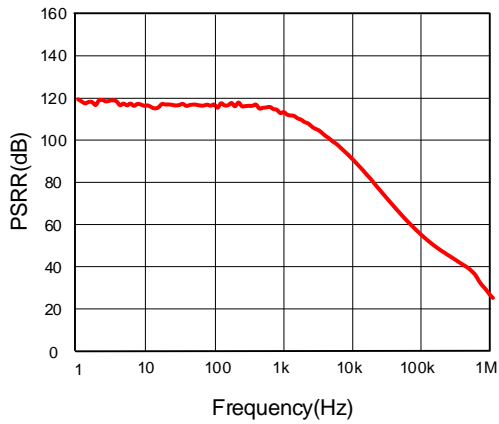

Gain vs. Frequency

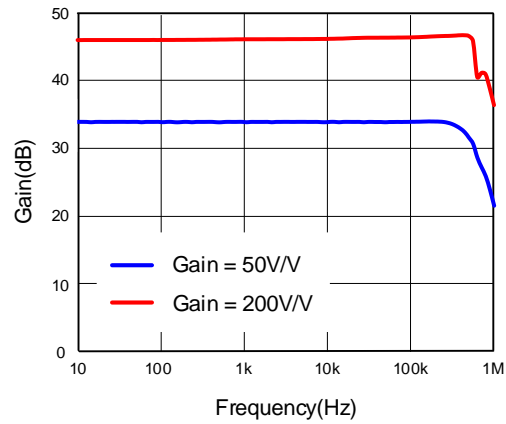

Input Voltage Noise Spectral Density vs. Frequency

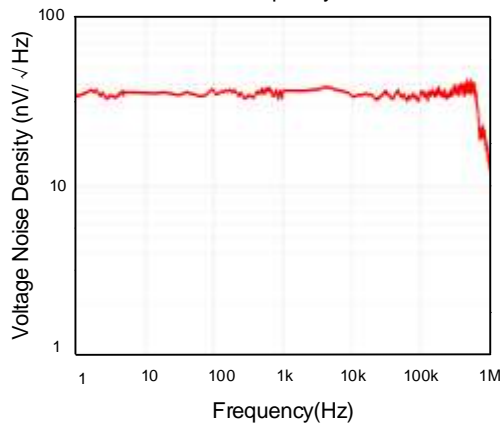

0.1Hz to 10Hz Voltage Noise

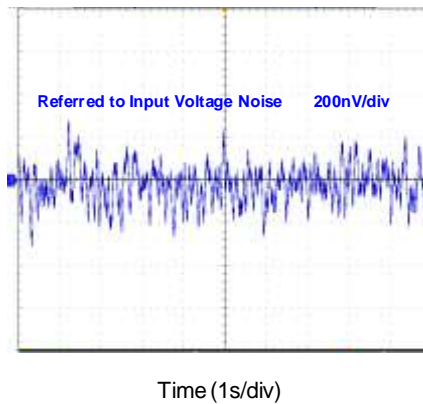

Common-Mode Voltage Transient Response

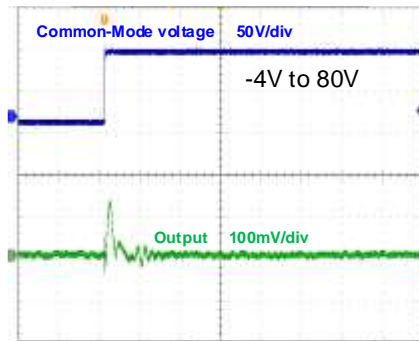

Time (8 μ s/div)

Common-Mode Voltage Transient Response

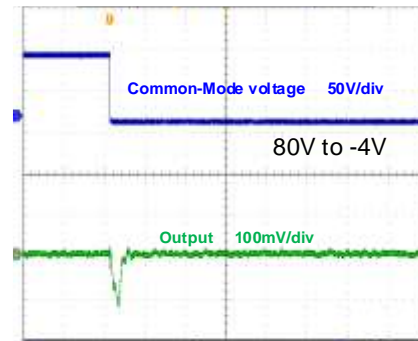

Time (8 μ s/div)

Application Information

The SQ52131x is a zero-drift current-sense amplifier designed to sense current across a wide common-mode voltage range with an excellent common-mode rejection ratio (CMRR).

The device features enhanced pulse width modulation (PWM) rejection minimizing the impact of common-mode transients on the output signal, particularly in applications involving PWM signals.

Functional Block Diagram

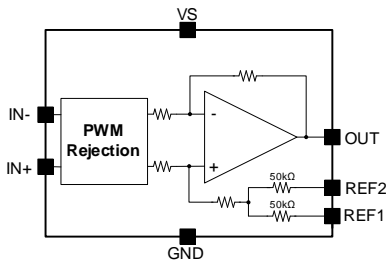

Figure 2. Functional Block Diagram

Enhanced PWM Rejection Operation

In applications heavily influenced by PWM signals, such as motor control or switching power supplies, large common-mode transients ($\Delta V/\Delta t$) are of great importance. The SQ52131x features enhanced PWM rejection, which improves the attenuation of large common-mode transients. Unlike traditional approaches that increase amplifier bandwidth to obtain higher common-mode transient rejection, the SQ52131x offers a smaller size and a more flexible design. Its high common-mode rejection technique reduces large transients ($\Delta V/\Delta t$) before they disrupt the system contributing to cost efficiency. Additionally, the combination of high AC CMRR and signal bandwidth minimizes output transients and ringing.

Unidirectional Operation and Reference Pin Configuration

For unidirectional operation, connect the two reference pins of the device to either the negative or positive rail. This configuration enables current measurement in one direction.

When using the SQ52131x in unidirectional mode with ground as the reference, both reference inputs should be connected to ground, as shown in Figure 3. In this configuration, if the input is at 0V differential, the output will also be grounded, meaning that the input polarity must be positive to drive the amplifier output above ground.

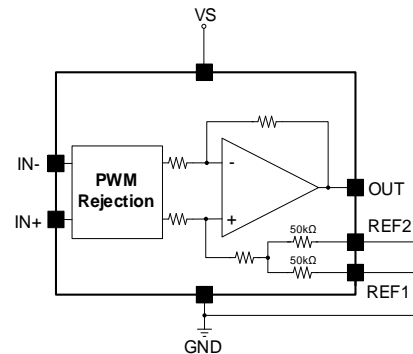

Figure 3. Ground Referenced Output

In unidirectional mode with VS as the reference, connect both reference pins to the positive supply, as shown in Figure 4. In this configuration, the input polarity must be negative to drive the amplifier output down.

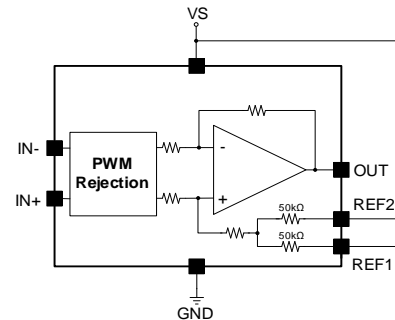

Figure 4. VS Referenced Output

Bidirectional Operation and Reference Pin Configuration

The SQ52131x supports bidirectional current detection by configuring the voltages of the two reference pins, allowing the output signal to reference any voltage within the input limit of the reference pins. A typical configuration sets the reference inputs at half-scale to enable an equal measurement range in both directions. However, the design of the two reference pins provides more options for voltage configurations.

Connecting the two reference pins to an external reference voltage biases the output, as shown in Figure 5. In this case, the output will use this external reference voltage as the reference and fluctuate based on the differential input.

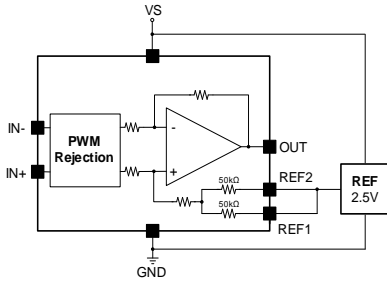

Figure 5. External Reference Output

Connecting one reference pin to VS and the other one to GND allows the internal voltage divider circuit to obtain the most common VS/2 reference, as shown in Figure 6.

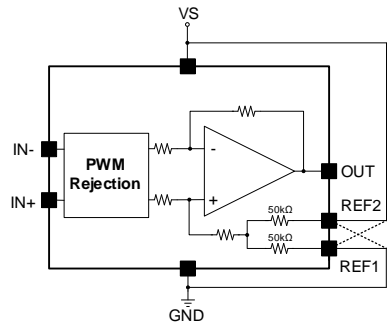

Figure 6. Mid-Supply Voltage Output

Similarly, connecting one REF pin to ground and the other REF pin to an external reference voltage creates a reference level at half of the external reference voltage, as shown in Figure 7.

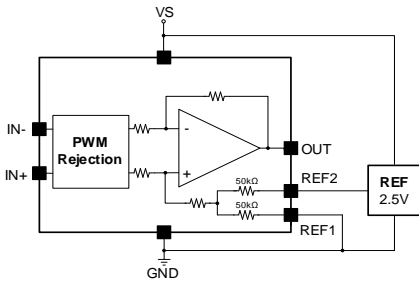

Figure 7. Mid-External Reference Output

The SQ52131x can also achieve a custom reference voltage by selecting different external divider resistors, as shown in Figure 8. In this configuration, it should be noted that the output of the amplifier should be a two-ended differential signal. This approach accounts for the internal impedance of the reference pins, which can influence the external voltage division.

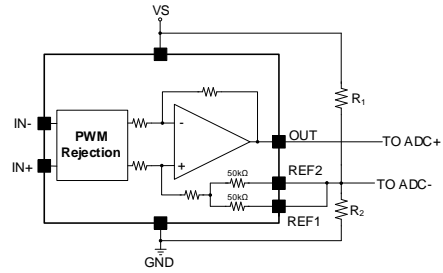

Figure 8. Setting the Reference Using a Resistor Divider

Selecting the Current-Sense Resistor (R_{SENSE})

The SQ52131x senses the magnitude of the current by measuring the differential voltage across the sense resistor, so the range of the current-sense is determined by the sense resistor value.

The optimal current-sense resistor is chosen based on the full-scale current to be measured and the gain of the selected device. Choosing the smallest current sense resistor maximizes the input range of the signal chain circuit, controlling the dynamic range of the input signal.

When selecting the current-sense resistor value, there is a trade-off between the accuracy of the current measurement and the maximum power dissipation of the current-sense resistor. A larger resistor increases the measured voltage signal, reduces the percentage of fixed errors in the measurement signal, and improves measurement accuracy. However, this also increases the power dissipation of the resistor, leading to temperature drift that can degrade the accuracy of the sensing resistor.

Based on these conditions, the measurement accuracy is inversely proportional to both the resistance value and the power dissipation due to the shunt resistor selection.

Because the SQ52131x has a gain of 50V/V and a very low offset voltage, a lower-value current-sense resistor is recommended. This choice helps ensure high measurement accuracy while reducing power dissipation.

Application Schematic

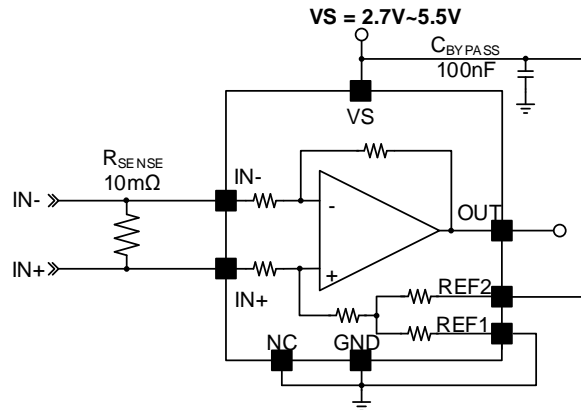

BOM List

Designator	Description	Part Number	MFR
CBYPASS	100nF/50V/X7R, 0603	GCJ188R71H104KA12D	muRata
RSENSE	10mΩ/1W, 2512, 1%	RL2512FK-070R01L	YAGEO

Layout Guidelines

For optimal performance, follow these PCB layout considerations:

- Use a Kelvin connection to connect the input pins to the current-sense resistor (R_{SENSE}). Due to the low resistance values of R_{SENSE} , poor PCB routing often leads to additional parasitic resistance between input pins, resulting in significant measurement errors. The Kelvin connection ensures that only R_{SENSE} impedance is detected between the input pins.
- Minimize the loop formed by these connections.
- Place the bypass capacitor (0.1μF MLCC is recommended) as close as possible to the VS and GND pins.

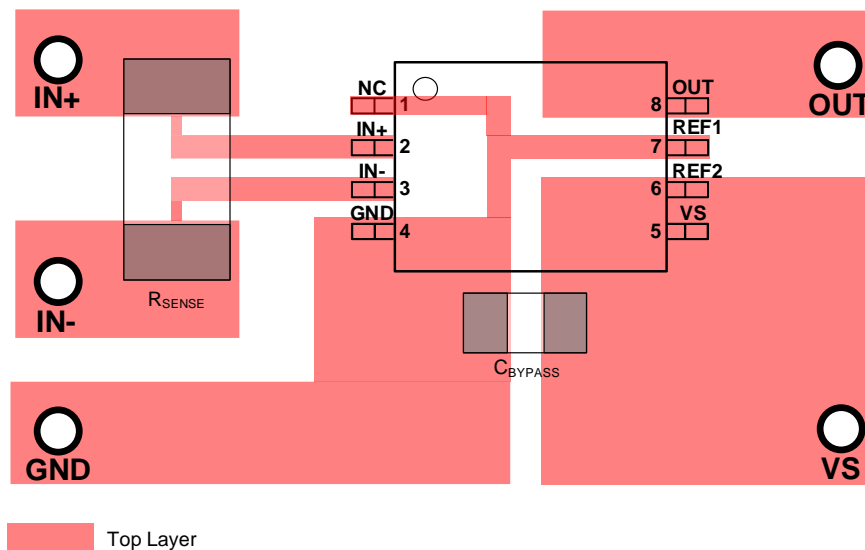

Figure 8. Recommended Layout (TSSOP8)

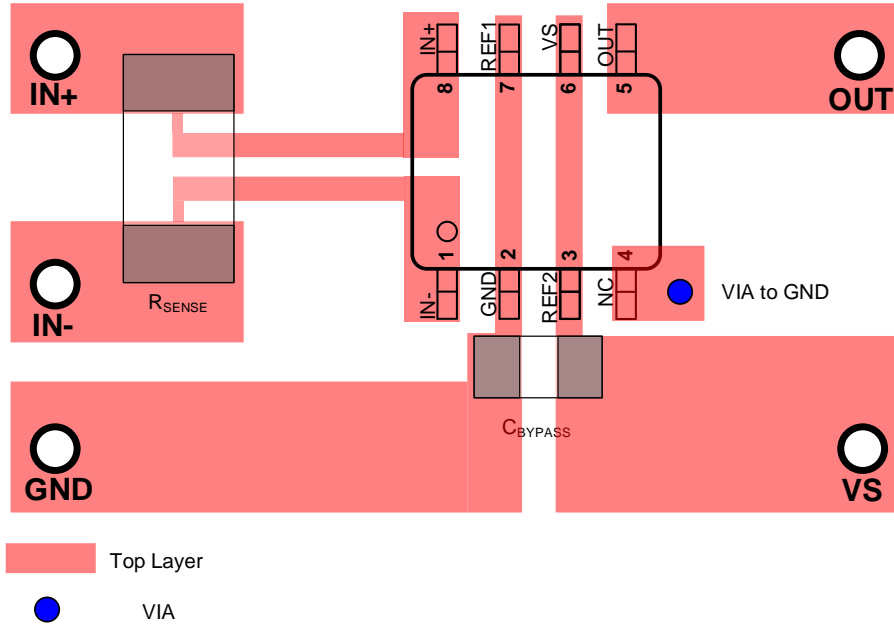
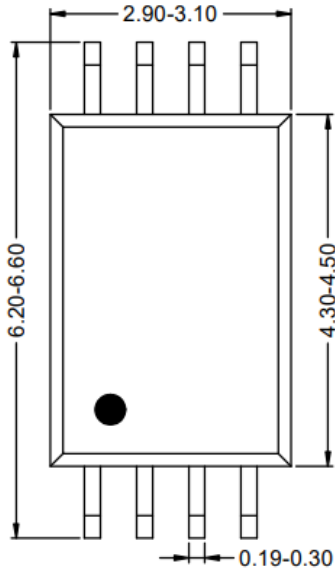
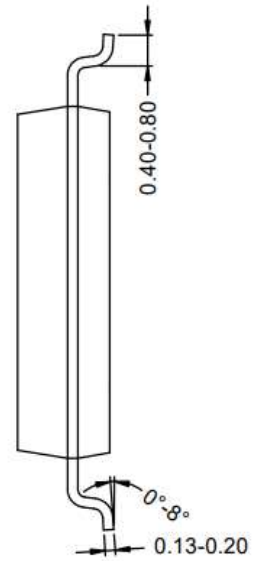

Figure 9. Recommended Layout (SOP8)

TSSOP8 Package Outline Drawing



Top View



Side View



Front View



Recommended PCB Layout

Note: All dimensions are in millimeters and exclude mold flash and metal burr.

SOP8 Package Outline and PCB Layout Design

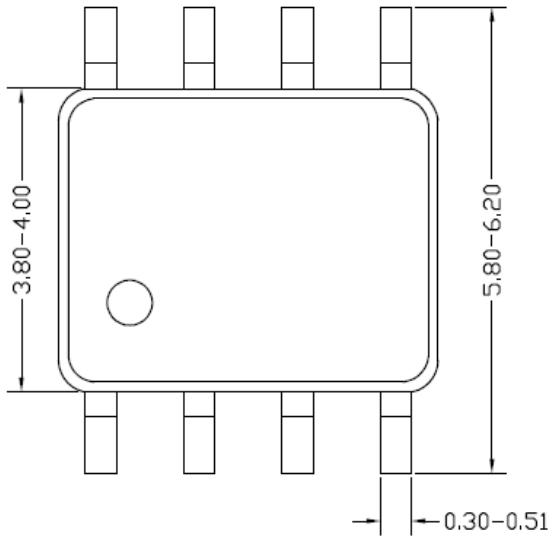

Top View

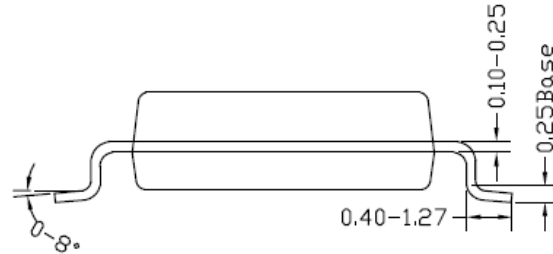

Side View

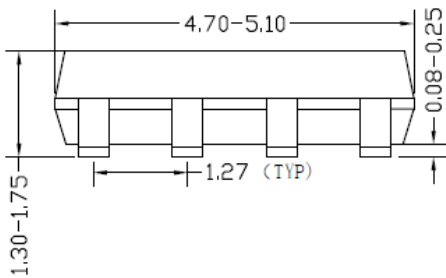

Front View

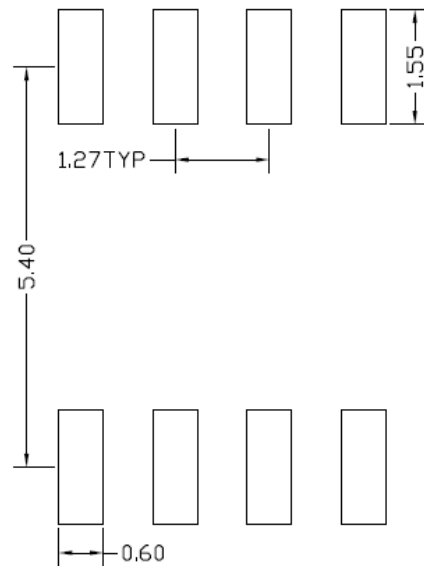

Recommended Pad Layout
(Reference Only)

Note: All dimensions are in millimeters and exclude mold flash and metal burr.

Tape and Reel Information

1. TSSOP8 Tape Dimensions and Pin 1 Orientation

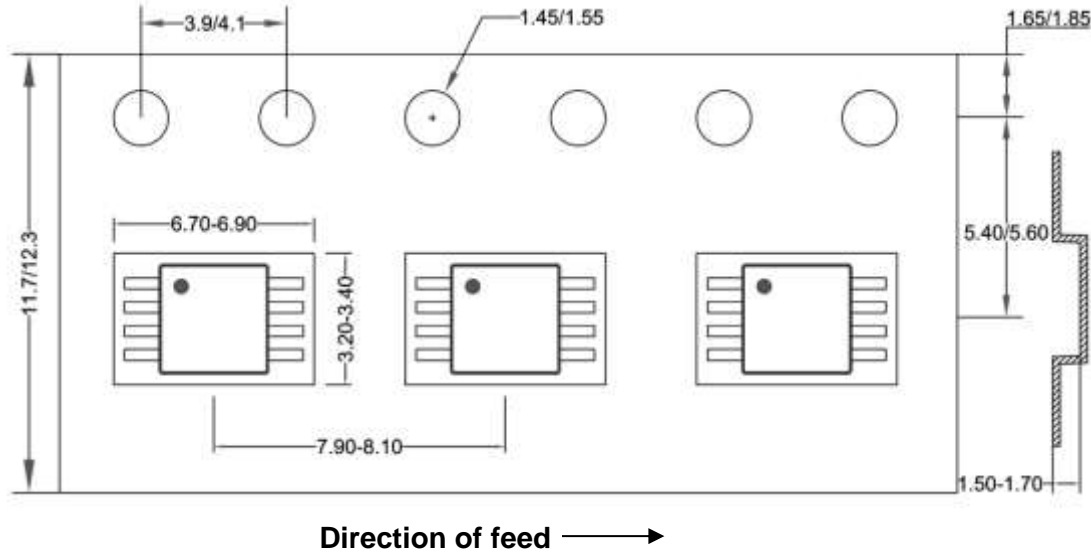

2. Reel Dimensions

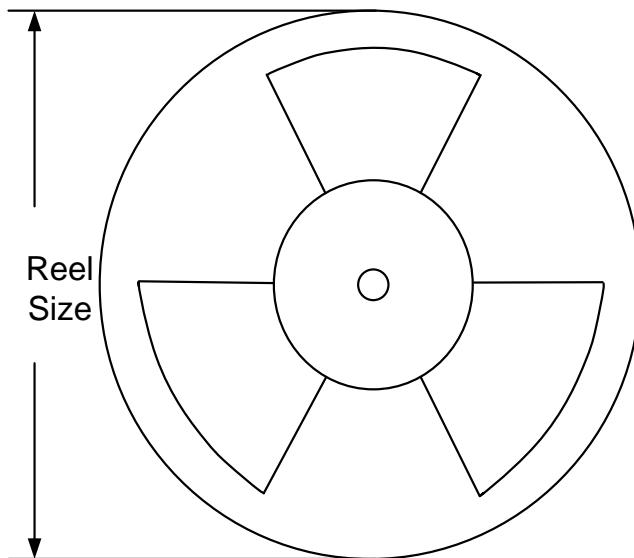

Package types	Tape width (mm)	Pocket pitch (mm)	Reel size (Inch)	Trailer length (mm)	Leader length (mm)	Qty per reel
						(pcs)
TSSOP8	12	8	13"	400	400	3000

Tape and Reel Information

1. SOP8 Tape Dimensions and Pin 1 Orientation

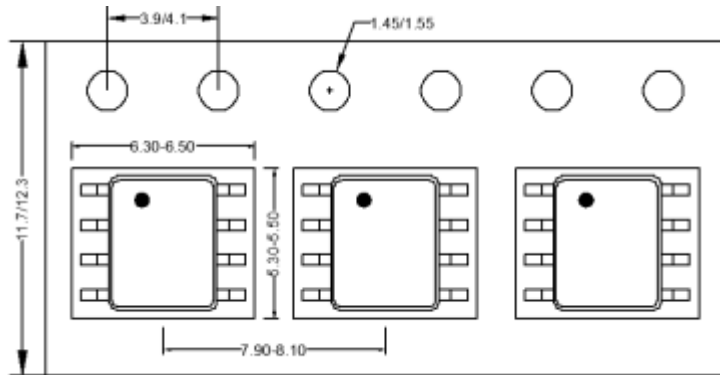

Direction of feed →

Reel Dimensions

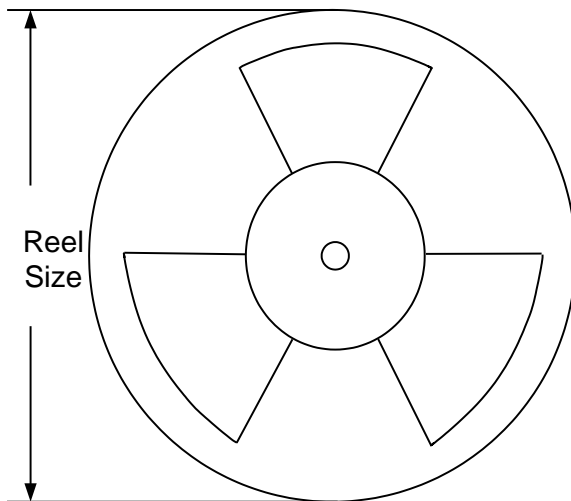

Package types	Tape width (mm)	Pocket pitch (mm)	Reel size (Inch)	Trailer length (mm)	Leader length (mm)	Qty per reel
						(pcs)
SOP8	12	8	13"	400	400	2500

Revision History

The revision history provided is for informational purposes only and is believed to be accurate, however, not warranted. Please make sure that you have the latest revision.

Date	Revision	Change
Nov. 30, 2025	Revision 1.0A	1. Added information of SQ52131EFAP 2. SQ52131CHMP MSL: 3-->1
Feb. 25, 2024	Revision 1.0	Initial Release



IMPORTANT NOTICE

1. **Right to make changes.** Silergy and its subsidiaries (hereafter Silergy) reserve the right to change any information published in this document, including but not limited to circuitry, specification and/or product design, manufacturing or descriptions, at any time and without notice. This document supersedes and replaces all information supplied prior to the publication hereof. Buyers should obtain the latest relevant information before placing orders and should verify that such information is current and complete. All semiconductor products are sold subject to Silergy's standard terms and conditions of sale.

2. **Applications.** Application examples that are described herein for any of these products are for illustrative purposes only. Silergy makes no representation or warranty that such applications will be suitable for the specified use without further testing or modification. Buyers are responsible for the design and operation of their applications and products using Silergy products. Silergy or its subsidiaries assume no liability for any application assistance or designs of customer products. It is customer's sole responsibility to determine whether the Silergy product is suitable and fit for the customer's applications and products planned. To minimize the risks associated with customer's products and applications, customer should provide adequate design and operating safeguards. Customer represents and agrees that it has all the necessary expertise to create and implement safeguards which anticipate dangerous consequences of failures, monitor failures and their consequences, lessen the likelihood of failures that might cause harm and take appropriate remedial actions. Silergy assumes no liability related to any default, damage, costs or problem in the customer's applications or products, or the application or use by customer's third-party buyers. Customer will fully indemnify Silergy, its subsidiaries, and their representatives against any damages arising out of the use of any Silergy components in safety-critical applications. It is also buyers' sole responsibility to warrant and guarantee that any intellectual property rights of a third party are not infringed upon when integrating Silergy products into any application. Silergy assumes no responsibility for any said applications or for any use of any circuitry other than circuitry entirely embodied in a Silergy product.

3. **Limited warranty and liability.** Information furnished by Silergy in this document is believed to be accurate and reliable. However, Silergy makes no representation or warranty, expressed or implied, as to the accuracy or completeness of such information and shall have no liability for the consequences of use of such information. In no event shall Silergy be liable for any indirect, incidental, punitive, special or consequential damages, including but not limited to lost profits, lost savings, business interruption, costs related to the removal or replacement of any products or rework charges, whether or not such damages are based on tort or negligence, warranty, breach of contract or any other legal theory. Notwithstanding any damages that customer might incur for any reason whatsoever, Silergy' aggregate and cumulative liability towards customer for the products described herein shall be limited in accordance with the Standard Terms and Conditions of Sale of Silergy.

4. **Suitability for use.** Customer acknowledges and agrees that it is solely responsible for compliance with all legal, regulatory and safety-related requirements concerning its products, and any use of Silergy components in its applications, notwithstanding any applications-related information or support that may be provided by Silergy. Silergy products are not designed, authorized or warranted to be suitable for use in life support, life-critical or safety-critical systems or equipment, nor in applications where failure or malfunction of a Silergy product can reasonably be expected to result in personal injury, death or severe property or environmental damage. Silergy assumes no liability for inclusion and/or use of Silergy products in such equipment or applications and therefore such inclusion and/or use is at the customer's own risk.

5. **Terms and conditions of commercial sale.** Silergy products are sold subject to the standard terms and conditions of commercial sale, as published at <http://www.silergy.com/stdterms>, unless otherwise agreed in a valid written individual agreement specifically agreed to in writing by an authorized officer of Silergy. In case an individual agreement is concluded only the terms and conditions of the respective agreement shall apply. Silergy hereby expressly objects to and denies the application of any customer's general terms and conditions with regard to the purchase of Silergy products by the customer.

6. **No offer to sell or license.** Nothing in this document may be interpreted or construed as an offer to sell products that is open for acceptance or the grant, conveyance or implication of any license under any copyrights, patents or other industrial or intellectual property rights. Silergy makes no representation or warranty that any license, either express or implied, is granted under any patent right, copyright, mask work right, or other intellectual property right. Information published by Silergy regarding third-party products or services does not constitute a license to use such products or services or a warranty or endorsement thereof. Use of such information may require a license from a third party under the patents or other intellectual property of the third party, or a license from Silergy under the patents or other intellectual property of Silergy.

For more information, please visit: www.silergy.com

© 2025 Silergy Corp.

All Rights Reserved.