

36V High-Speed Zero-Drift Voltage Output Current-Shunt Monitor with High-Speed Overcurrent Comparator

General Description

The SY24631 includes a high common-mode, current-sensing amplifier, as well as a high-speed comparator that can be configured to detect over-current conditions. The Current Sense Amplifier is used to accurately measure a small voltage developed across a shunt resistor and provide a proportional analog value at its output.

The built-in comparator measures the voltage developed at the output of the Current Sense Amplifier and compares that voltage with an externally configured threshold. When the voltage at the Amplifier output is higher than the threshold, its open-drain output will be driven low, effectively enabling fast over-current detection in a system. A single external resistor can be used to configure the over-current threshold. This current-shunt monitor can measure differential voltage signals on common-mode voltages that can vary from 0V up to 36V, independent of the supply voltage.

The open-drain Alert Output can be configured to operate in either transparent mode or latched mode. The device alert response time is under 0.75 μ s, which allows for quick detection of over-current events.

The SY24631 operates from a single 2.7V to 5.5V supply, drawing a maximum supply current of 400 μ A. The device is specified over the extended operating temperature range (-40 $^{\circ}$ C to +125 $^{\circ}$ C), and is available in an 8-pin MSOP package.

Features

- Wide Common-mode Range: 0V to 36V
- Dual Output: Amplifier and Comparator Output
- High-Accuracy Amplifier:
 - Offset Voltage: 125 μ V (Max)
 - Offset Voltage Drift: 0.5 μ V/ $^{\circ}$ C (Max)
 - Gain Error: 0.1% (Max)
 - Gain Error Drift: 10ppm/ $^{\circ}$ C (Max)
- Available Amplifier Gain: 20V/V
- Programmable Alert Threshold Setting through a Single Resistor
- Total Alert Response Time: 0.75 μ s
- Open-drain Output with Latching Mode
- Package: MSOP8

Applications

- Over-current Protection
- Power-Supply Protection
- Circuit Breakers
- Computers and Servers
- Telecom Equipment
- Battery Management

Typical Application

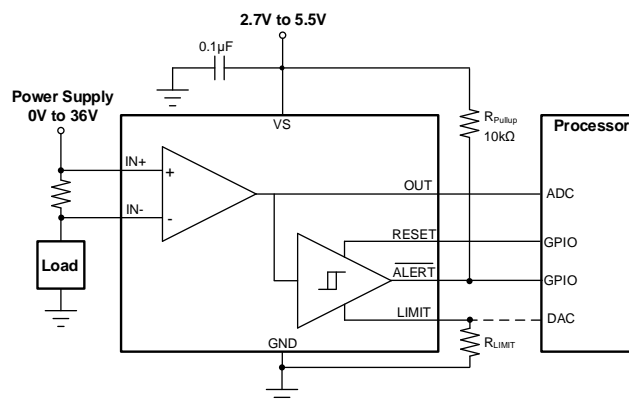

Figure 1. Schematic Diagram

Ordering Information

Ordering Part Number	Package Type	Top Mark
SY24631CAP	MSOP8	DYTxyz

x = year code, y = week code, z = lot number code

Pinout (Top View)

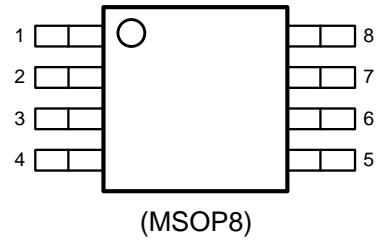

Pin Description

Pin No	Pin Name	Pin Description
1	V _s	Power supply, 2.7V to 5.5V.
2	OUT	Output voltage.
3	LIMIT	Alert threshold limit input.
4	GND	Ground.
5	RESET	Transparent or latch mode selection input.
6	ALERT	Over limit alert; active-low, open-drain output.
7	IN-	Connect to load side of shunt resistor.
8	IN+	Connect to supply side of shunt resistor.

Absolute Maximum Ratings

Parameter (Note 1)	Min	Max	Unit
V _s	-0.3	6	V
V _{IN+} - V _{IN-} (Differential)	-40	40	
V _{IN+} , V _{IN-} (Common-Mode)	-0.3	40	
Alert Output V _{ALERT}	-0.3	6	
Input Voltage at Any Pin	-0.3	V _s +0.3	
Maximum Junction Temperature		150	°C
Storage Temperature Range	-65	150	
ESD: HBM (Human Body Model)	± 2000		V
ESD: CDM (Charged Device Model)	± 1000		V

Thermal Information

Parameter (Note 2)	Max	Unit
θ _{JA} Junction-to-Ambient Thermal Resistance	175	°C/W
θ _{JC} Junction-to-Case Thermal Resistance (top)	40	

Recommended Operating Conditions

Parameter (Note 3)	Min	Max	Unit
V _s		5	V
Common-mode, V _{IN+} , V _{IN-}		12	
Operation Temperature	-40	125	°C

Electrical Characteristics

$T_A = 25^\circ\text{C}$, $V_{IN} = V_{IN+} - V_{IN-} = 10\text{mV}$, $V_S = 5\text{V}$, $V_{IN+} = 12\text{V}$ and $V_{LIMIT} = 2\text{V}$, unless otherwise noted.

Parameter (Note 4)	Symbol	Conditions	Min	Typ	Max	Units
Input						
Input Voltage	V_{CM}		0		36	V
Differential Input Voltage	V_{IN}	$V_{IN} = V_{IN+} - V_{IN-}$	0		250	mV
Common-Mode Rejection	CMR	$V_{IN} = 0\text{V to } 36\text{V}$, $T_A = -40^\circ\text{C to } +125^\circ\text{C}$	100	110		dB
Offset Voltage, RTI (Note 5)	V_{OS}			± 25	± 125	μV
Offset Voltage Drift, RTI	dV_{OS}/dT	$T_A = -40^\circ\text{C to } +125^\circ\text{C}$		0.1	0.5	$\mu\text{V}/^\circ\text{C}$
Power Supply Rejection Ratio	PSR	$V_S = 2.7\text{V to } 5.5\text{V}$, $V_{IN+} = 12\text{V}$, $T_A = -40^\circ\text{C to } +125^\circ\text{C}$		± 0.1	± 10	$\mu\text{V/V}$
Input Bias Current (Note 6)	I_B			125		μA
Input Offset Current (Note 7)	I_{OS}			± 0.1		μA
Output						
Gain	G			20		V/V
Gain Error		$V_{OUT} = 0.5\text{V to } V_S - 0.5\text{V}$		± 0.03	± 0.1	%
		$T_A = -40^\circ\text{C to } +125^\circ\text{C}$		3	10	ppm/ $^\circ\text{C}$
Nonlinearity Error		$V_{OUT} = 0.5\text{V to } V_S - 0.5\text{V}$		± 0.01		%
Maximum Capacitive Load		No sustained oscillation		1		nF
Voltage Output						
Swing to V_S Power Supply Rail		$R_L = 10\text{k}\Omega$ to GND, $T_A = -40^\circ\text{C to } +125^\circ\text{C}$		$V_S - 0.05$	$V_S - 0.1$	V
Swing to GND		$R_L = 10\text{k}\Omega$ to GND, $T_A = -40^\circ\text{C to } +125^\circ\text{C}$		$V_{GND} + 20$	$V_{GND} + 30$	mV
Frequency Response						
Bandwidth	BW			500		kHz
Slew Rate	SR			4		V/ μs
Noise, RTI						
Voltage Noise Density				30		nV/ $\sqrt{\text{Hz}}$
Comparator						
Total Alert Propagation Delay	t_p	Input overdrive = 1mV (Note 8) V_{IN} to alert propagation		0.75		μs
Slew-Rate-Limited t_p		V_{OUT} step = 0.5V to 4.5V, $V_{LIMIT} = 4\text{V}$		1		
Limit Threshold Output Current	I_{LIMIT}		79.4	80	80.6	μA
		$T_A = -40^\circ\text{C to } +125^\circ\text{C}$	78.8		81.2	
Comparator Offset Voltage	V_{OS}			1	3.5	mV
Hysteresis	HYS			20		mV
High-Level Input Voltage	V_{IH}		1.4		$V_S + 0.3$	V
Low-Level Input Voltage	V_{IL}		0		0.4	V
Alert Low-Level Output Voltage	V_{OL}	$I_{OL} = 3\text{mA}$		70	300	mV
ALERT Terminal Leakage Input Current		$V_{OH} = 3.3\text{V}$		0.1	1	μA
Digital Leakage Input Current		$0 < V_{IN} < V_S$		1		μA
Power Supply						
Operating Supply Range	V_S	$T_A = -40^\circ\text{C to } +125^\circ\text{C}$	2.7		5.5	V
Quiescent Current	I_Q	$V_{IN} = 0\text{mV}$, $T_A = 25^\circ\text{C}$		300	380	μA
		$T_A = -40^\circ\text{C to } +125^\circ\text{C}$			400	



Note 1: Stresses beyond the “Absolute Maximum Ratings” may cause permanent damage to the device. These are stress ratings only. Functional operation of the device at these or any other conditions beyond those indicated in the operational sections of the specification is not implied. Exposure to absolute maximum rating conditions for extended periods may affect device reliability.

Note 2: Package thermal resistance is measured in the natural convection at $T_A = 25^\circ\text{C}$ on an 8.5cm x 8.5cm single-layer Silergy Evaluation Board.

Note 3: The device is not guaranteed to function outside its operating conditions.

Note 4: Production testing is performed at 25°C ; limits at -40°C to $+125^\circ\text{C}$ are guaranteed by design, test, or statistical correlation.

Note 5: RTI = Referred to Input.

Note 6: Input bias current is decided by the average of the input currents of the pin IN+ and IN-.

Note 7: Input offset current is decided by the error between the input currents of the pin IN+ and IN-.

Note 8: Overdrive = $(V_{OUT} - V_{LIMIT}) / \text{Gain}$.

Application Information

Operation

The SY24631 is a fixed-gain, zero-drift current-sense amplifier that amplifies the differential voltage across an external shunt resistor to create an output voltage.

The device features a 0V to 36V common-mode independent of its supply voltage in applications that use low-side or high-side configurations. The SY24631 can withstand, without sustaining damage, the full 36V common-mode voltage at the input pins when the supply voltage is removed.

The zero-drift topology enables high-precision measurements with typical input offset voltages as low as 125 μ V, and with a temperature contribution of only 0.5 μ V/ $^{\circ}$ C over the full temperature range of -40 $^{\circ}$ C to +125 $^{\circ}$ C. The low total offset voltage of the SY24631 allows smaller current-sensing shunt resistor values to be used, minimizing the power loss across it.

The built-in comparator uses a single external resistor to set the corresponding current threshold level that is used for signaling over-current conditions. Combining the precise measurement of the current-sensing amplifier with the comparator enables creating a fast acting overcurrent-detection device.

Alert Output

The ALERT pin is an active-low, open-drain output that is designed to be pulled low when the monitored current exceeds the configured threshold. This open-drain output pin should be connected to supply voltage through a 10k Ω pull-up resistor. The ALERT pin can be pulled up to a voltage beyond the supply voltage V_s , but the value must not exceed 5.5 V.

When the output voltage of the amplifier is lower than the voltage developed at the LIMIT pin, the comparator output will be in the default high state. When the amplifier output voltage exceeds the threshold voltage set using the LIMIT pin, the comparator output will become active and be pulled low, indicating that an over-current condition has occurred.

Alert Mode

Using the RESET pin, the output can be configured to operate in either Transparent or Latched mode. This will change the behavior of the output when the over-current condition is removed, as described in the following paragraphs.

Transparent Output Mode

The device will be set to Transparent Mode when the RESET pin is pulled low. In this mode, the Alert output changes state following the input signal with respect to the programmed alert threshold. For example, when the differential input signal rises above the alert threshold, the ALERT output pin will be pulled low. As soon as the differential input signal drops below the alert threshold, the output will return to the default high output state.

When connect the ALERT pin to a hardware interrupt input on a microcontroller, the output state change of the ALERT pin in Transparent Mode can be directly detected and over-current conditions can be handled.

Latch Output Mode

The latch mode is designed to accommodate applications which do not have the functionality available to continuously monitor the state of the output ALERT pin.

The device can be configured to operate in Latch Mode by connecting the RESET pin to a HIGH level. In this mode when an over-current condition is removed, the ALERT pin will not return to the default high state.

To clear the alert, the RESET pin must be pulled low for at least 100ns. Pulling the RESET pin low allows the ALERT pin to return to the default high level, provided that the differential input signal has dropped below the alert threshold. If the input signal is still above the threshold limit when the RESET pin is pulled low, the ALERT pin will remain low.

After processing the over-current condition the external controller can return the device to Latch Mode by setting the RESET pin by to logic high.

Transparent Output vs. Latch Output

The SY24631 is placed into the corresponding output mode by driving the voltage level at the RESET pin, as shown in Table 1.

Table 1. Output Mode Settings

Output Mode	RESET Terminal Setting
Transparent mode	RESET = low
Latch mode	RESET = high

The Alert pin behavior is shown in Figure 2 for the Latch and Transparent Modes.

When V_{OUT} drops below the V_{LIMIT} -Hysteresis threshold for the first time, the RESET pin will be pulled high by the external resistor.

When the RESET pin is pulled high, the device will be set to Latch mode. In this mode the Alert output state will not return to high when the V_{OUT} drops below the V_{LIMIT} -Hysteresis threshold.

When the RESET pin is pulled low, the ALERT pin will return to the default high level, indicating that the V_{OUT} is below the V_{LIMIT} -Hysteresis threshold. When the V_{OUT} drops below the V_{LIMIT} -Hysteresis threshold for the second time, the RESET pin will already be pulled low. The device is set to transparent mode at this point, and the ALERT pin is pulled back high as soon as the V_{OUT} drops below the V_{LIMIT} -Hysteresis threshold.

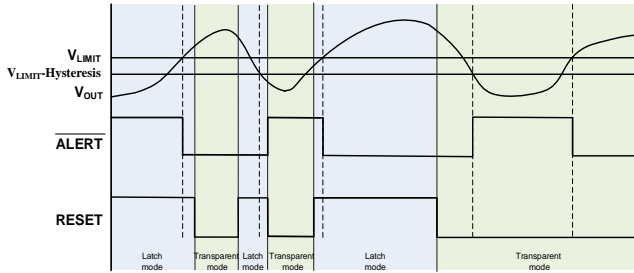

Figure 2. Transparent vs. Latch Mode

Current-Limit Threshold Setting

The SY24631 will determine if an overcurrent event is present by comparing the amplified measured voltage developed across the current-sensing shunt resistor with the corresponding voltage configured using the LIMIT pin. The threshold voltage for the LIMIT pin can be set using a single external resistor, or by connecting an external voltage source to the LIMIT pin.

Resistor-Controlled Current Limit

One approach for setting the limit threshold voltage is to connect a resistor from the LIMIT pin to ground. The value of this resistor R_{LIMIT} will be chosen to create a corresponding voltage at the LIMIT pin that is equivalent to the output voltage V_{OUT} , when the maximum desired load current is flowing through the current-sensing resistor. An internal $80\mu A$ current source is connected to the LIMIT pin to configure the desired threshold by choosing the value of the R_{LIMIT} resistor.

Voltage Source Controlled Current Limit

An alternate method for setting the over-current threshold is to connect the LIMIT pin to a programmable DAC (digital-to-analog converter). The benefit of this method is the ability to adjust the threshold, as the system operating conditions change.

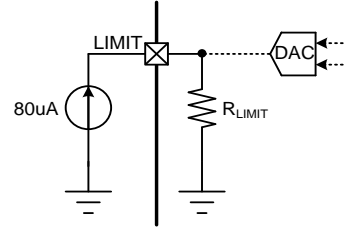

Figure 3. Typical Circuit for Setting V_{LIMIT}

Hysteresis

The onboard comparator in the SY24631 is designed to reduce the possibility of oscillations when the measured current is near the over-current threshold. A hysteresis level (HYS) of 20mV is utilized for proper operation, as shown in Figure 4.

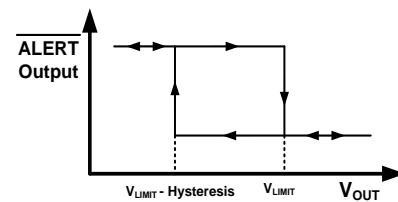
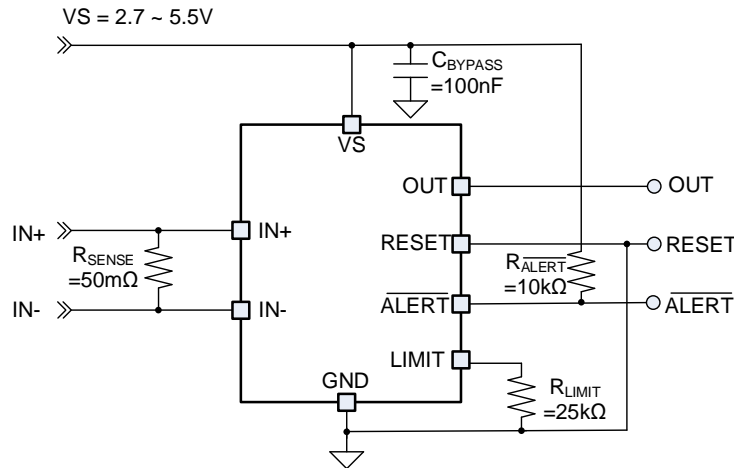

Figure 4. V_{LIMIT} Hysteresis

Application Schematic



BOM List

Designator	Description	Part Number	MFR
C _{BYPASS}	100nF/50V/X7R, 0603	GCJ188R71H104KA12D	muRata
R _{SENSE}	50mΩ/1W, 1%, 2512	RL2512FK-070R01L	YAGEO
R _{LIMIT}	25kΩ, 1%, 0603		
R _{ALERT}	10kΩ, 1%, 0603		

Layout Design

For optimal design, follow these PCB layout considerations:

- Using a Kelvin connection to connect the input pins to the current-sensing resistor R_{SENSE} . Due to the low resistance values of R_{SENSE} , poor PCB routing often leads to additional parasitic resistance between input pins, resulting in additional errors that cannot be ignored, this connection technique ensures that only R_{SENSE} impedance is detected between the input pins. Minimizing the loop formed by these connections.
- Place the bypass capacitor (a 0.1μF MLCC is recommended) very near VCC and GND.
- To limit the generation of additional capacitance on this node, connect the R_{LIMIT} to the GND pin as directly as possible.

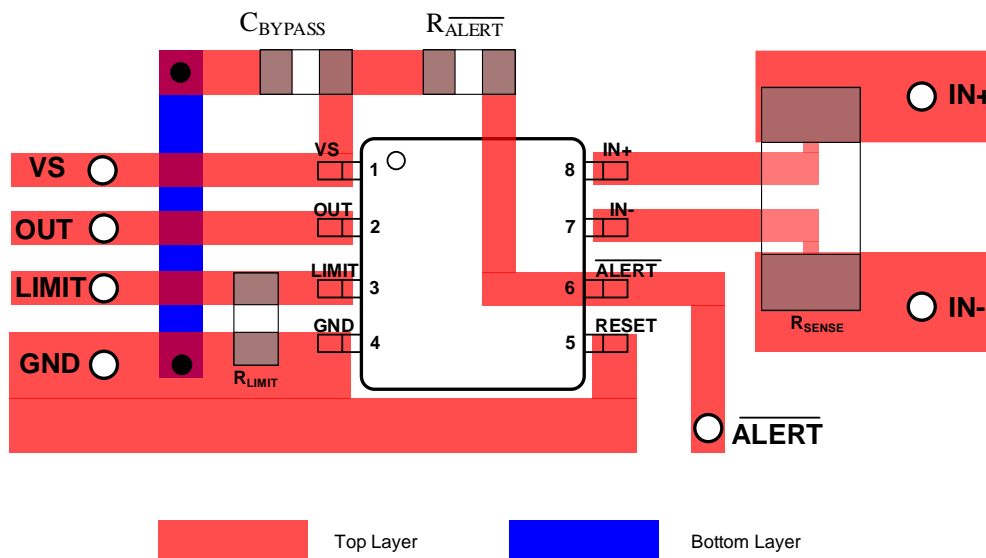
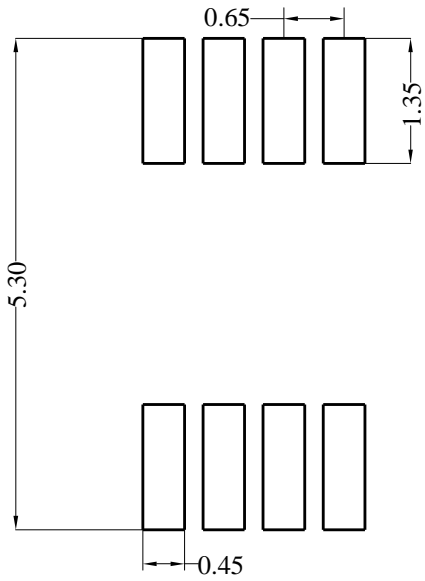
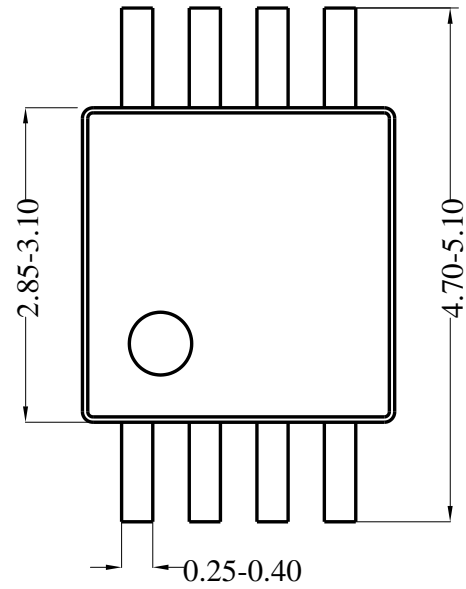

Figure 5. Recommended Layout

MSOP8 Package Outline Drawing



Recommended pad layout



Top view

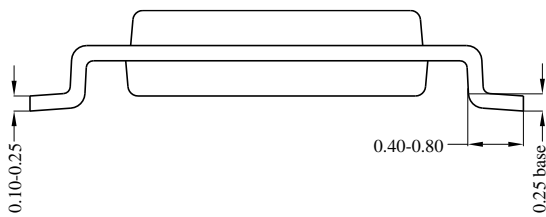

Side view A

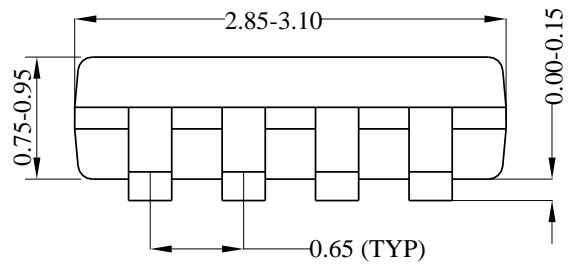

Side view B

Note: All dimensions are in millimeters and exclude mold flash and metal burr.

Taping and Reel Specification

Package orientation

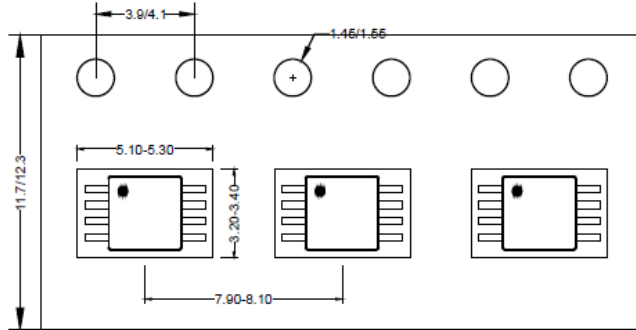

Feeding direction \longrightarrow

Carrier tape and reel specification for packages

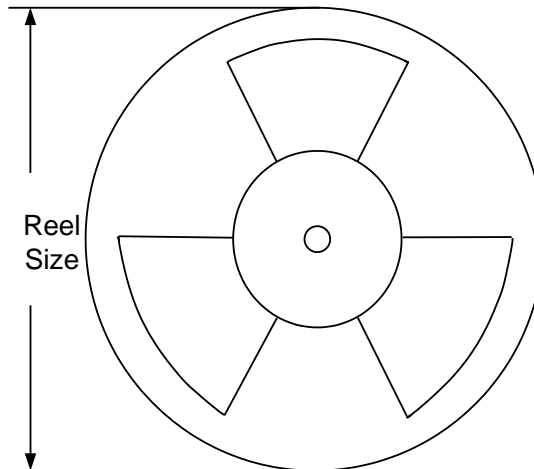

Package types	Tape width (mm)	Pocket pitch(mm)	Reel size (Inch)	Trailer length(mm)	Leader length (mm)	Qty per reel
MSOP8	12	8	13"	400	400	3000

Others: N/A



Revision History

The revision history provided is for informational purpose only and is believed to be accurate, however, not warranted. Please make sure that you have the latest revision.

Date	Revision	Change
Sept.6, 2022	Revision 0.9	Initial Release
Sept.6, 2023	Revision 1.0	Production Release



IMPORTANT NOTICE

- 1. Right to make changes.** Silergy and its subsidiaries (hereafter Silergy) reserve the right to change any information published in this document, including but not limited to circuitry, specification and/or product design, manufacturing or descriptions, at any time and without notice. This document supersedes and replaces all information supplied prior to the publication hereof. Buyers should obtain the latest relevant information before placing orders and should verify that such information is current and complete. All semiconductor products are sold subject to Silergy's standard terms and conditions of sale.
- 2. Applications.** Application examples that are described herein for any of these products are for illustrative purposes only. Silergy makes no representation or warranty that such applications will be suitable for the specified use without further testing or modification. Buyers are responsible for the design and operation of their applications and products using Silergy products. Silergy or its subsidiaries assume no liability for any application assistance or designs of customer products. It is customer's sole responsibility to determine whether the Silergy product is suitable and fit for the customer's applications and products planned. To minimize the risks associated with customer's products and applications, customer should provide adequate design and operating safeguards. Customer represents and agrees that it has all the necessary expertise to create and implement safeguards which anticipate dangerous consequences of failures, monitor failures and their consequences, lessen the likelihood of failures that might cause harm and take appropriate remedial actions. Silergy assumes no liability related to any default, damage, costs or problem in the customer's applications or products, or the application or use by customer's third-party buyers. Customer will fully indemnify Silergy, its subsidiaries, and their representatives against any damages arising out of the use of any Silergy components in safety-critical applications. It is also buyers' sole responsibility to warrant and guarantee that any intellectual property rights of a third party are not infringed upon when integrating Silergy products into any application. Silergy assumes no responsibility for any said applications or for any use of any circuitry other than circuitry entirely embodied in a Silergy product.
- 3. Limited warranty and liability.** Information furnished by Silergy in this document is believed to be accurate and reliable. However, Silergy makes no representation or warranty, expressed or implied, as to the accuracy or completeness of such information and shall have no liability for the consequences of use of such information. In no event shall Silergy be liable for any indirect, incidental, punitive, special or consequential damages, including but not limited to lost profits, lost savings, business interruption, costs related to the removal or replacement of any products or rework charges, whether or not such damages are based on tort or negligence, warranty, breach of contract or any other legal theory. Notwithstanding any damages that customer might incur for any reason whatsoever, Silergy' aggregate and cumulative liability towards customer for the products described herein shall be limited in accordance with the Standard Terms and Conditions of Sale of Silergy.
- 4. Suitability for use.** Customer acknowledges and agrees that it is solely responsible for compliance with all legal, regulatory and safety-related requirements concerning its products, and any use of Silergy components in its applications, notwithstanding any applications-related information or support that may be provided by Silergy. Silergy products are not designed, authorized or warranted to be suitable for use in life support, life-critical or safety-critical systems or equipment, nor in applications where failure or malfunction of Silergy product can reasonably be expected to result in personal injury, death or severe property or environmental damage. Silergy assumes no liability for inclusion and/or use of Silergy products in such equipment or applications and therefore such inclusion and/or use is at the customer's own risk.
- 5. Terms and conditions of commercial sale.** Silergy products are sold subject to the standard terms and conditions of commercial sale, as published at <http://www.silergy.com/stdterms>, unless otherwise agreed in a valid written individual agreement specifically agreed to in writing by an authorized officer of Silergy. In case an individual agreement is concluded only the terms and conditions of the respective agreement shall apply. Silergy hereby expressly objects to and denies the application of any customer's general terms and conditions with regard to the purchase of Silergy products by the customer.
- 6. No offer to sell or license.** Nothing in this document may be interpreted or construed as an offer to sell products that is open for acceptance or the grant, conveyance or implication of any license under any copyrights, patents or other industrial or intellectual property rights. Silergy makes no representation or warranty that any license, either express or implied, is granted under any patent right, copyright, mask work right, or other intellectual property right. Information published by Silergy regarding third-party products or services does not constitute a license to use such products or services or a warranty or endorsement thereof. Use of such information may require a license from a third party under the patents or other intellectual property of the third party, or a license from Silergy under the patents or other intellectual property of Silergy.

For more information, please visit: www.silergy.com

© 2025 Silergy Corp.

All Rights Reserved.