

### General Description

The SY2A55104 and SY2A55105 fixed-gain, high-precision, high-side or low-side, current-sense amplifiers with voltage output are suitable for bidirectional (charge/discharge) or unidirectional current measurements. The SY2A55104 provides 50V/V output gain and the SY2A55105 provides 100V/V output gain.

The SY2A55104/5 use a low-offset, zero-drift architecture and operate across the -0.3V to 26V input common-mode voltage range, which is independent of supply voltage. The precision input offset voltage ( $V_{OS}$ ) allows the devices to measure the low-voltage drop very accurately.

The SY2A55104/5 are designed to operate from a 3V to 5.5V supply and draw just 80 $\mu$ A (typ) quiescent current.

The devices are provided in an SOT363 package and are specified over the extended industrial temperature range of -40°C to 125°C. The device is AEC-Q100 Qualified.

### Features

- Voltage-Output, Current-sense Monitor
- -0.3V–26V Common-Mode Operation Range
- 100 $\mu$ A (Maximum) Quiescent Current
- High Accuracy:  $\pm 0.5\%$  Gain Error (Maximum)
- Gain: 50V/V (SY2A55104), 100V/V (SY2A55105)
- Amplifier Output Referenced to  $V_{REF}$  input
- Shunt Maximum Input Voltage Range:
  - SY2A55104:
    - -40mV to 40mV ( $V_{CC}=5V$ ,  $REF=2.5V$ )
    - 1mV to 90mV ( $V_{CC}=5V$ ,  $REF=0V$ )
  - SY2A55105:
    - -20mV to 20mV ( $V_{CC}=5V$ ,  $REF=2.5V$ )
    - 1mV to 45mV ( $V_{CC}=5V$ ,  $REF=0V$ )
- Low Offset Voltage(Maximum):
  - $\pm 100\mu V$  (SY2A55104),
  - $\pm 50\mu V$  (SY2A55105)
- 0.5 $\mu V/^\circ C$  Offset Drift (Maximum)
- 10ppm/ $^\circ C$  Gain Drift (Maximum)
- AEC-Q100 Qualified
- Package: SOT363

### Applications

- On-Board Charge (OBC)
- Battery Management System (BMS)
- Body Control Modules
- Over-current Detection
- Wireless Charging

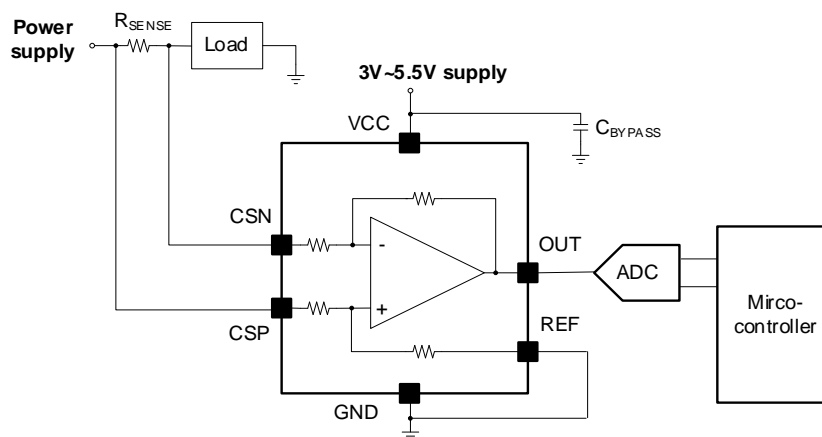

Figure 1. Typical Application

Figure 1 shows the basic connections of the SY2A55104/5. The two-input pin CSN and CSP should be connected to the shunt resistor as closely as possible to minimize any resistance in series with the sense resistor. A bypass capacitor must be connected to the power supply for stability.

## Ordering Information

Ordering Part Number	Package type	Top Mark
SY2A55104AHT	SOT363 RoHS Compliant and Halogen Free	<b>exyz</b>
SY2A55105AHA	SOT363 RoHS Compliant and Halogen Free	<b>bxyz</b>

*x = year code, y = week code, z = lot number code*

## Pinout (Top View)

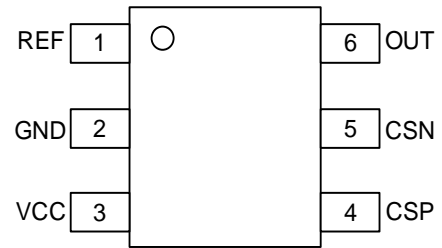

(SOT363)

## Pin Description

Pin No	Pin Name	Pin Description
1	REF	Reference voltage input, 0V to V <sub>CC</sub> .
2	GND	Ground.
3	V <sub>CC</sub>	Power supply, 3V to 5.5V.
4	CSP	Connect to supply side of shunt resistor.
5	CSN	Connect to load side of shunt resistor.
6	OUT	Amplifier Output.

## Block Diagram

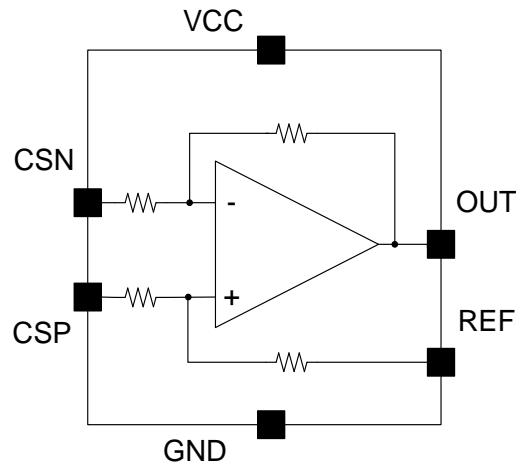

Figure 2. Block Diagram



## Absolute Maximum Ratings

Parameter (Note 1)	Min	Max	Unit
V <sub>CC</sub>	-0.3	6	V
CSP, CSN (Common-Mode)	-0.3	29	
CSP, CSN (Differential)	-29	29	
REF	-0.3	V <sub>CC</sub>	
OUT	-0.3	V <sub>CC</sub>	
Junction Temperature, Operating	-40	150	°C
Storage Temperature	-65	150	
ESD: HBM (Human Body Model)	± 4000		V
ESD: CDM (Charged Device Model)	± 1000		V

## Thermal Information

Parameter (Note 2)	Min	Max	Unit
θ <sub>JA</sub> Junction-to-Ambient Thermal Resistance		321	°C/W
θ <sub>JC</sub> Junction-to-Case Thermal Resistance		60	
P <sub>D</sub> Power Dissipation T <sub>A</sub> = 25°C		0.31	W

## Recommended Operating Conditions

Parameter (Note 3)	Min	Max	Unit	
CSP, CSN (Differential)	SY2A55104	-40	40	mV
	SY2A55105	-20	20	mV
V <sub>CC</sub>	3	5.5	V	
REF	GND	V <sub>CC</sub>		
Junction Temperature Range	-40	125	°C	

## Electrical Characteristics

$T_A = -40^{\circ}\text{C}$  to  $125^{\circ}\text{C}$ ,  $V_{CC} = 5\text{V}$ ,  $V_{SENSE} = \text{CSP-CSN} = 0\text{mV}$ ,  $\text{CSP} = 12\text{V}$ , and  $V_{REF} = 2.5\text{V}$ , unless otherwise noted.

Parameter		Symbol	Test condition	Min	Typ	Max	Unit	
Input	Common-Mode Input	$V_{CM}$		-0.3		26	V	
	Common-Mode Rejection Ratio	CMRR	CSP = CSN = 0V to 26V, $V_{SENSE} = 0\text{mV}$	SY2A55104	100	116	dB	
				SY2A55105	105	125		
	Offset Voltage, RTI (Note 4)	$V_{OS}$	$V_{SENSE} = 0\text{mV}$ , $T_A = 25^{\circ}\text{C}$	SY2A55104		$\pm 5$	$\pm 100$	$\mu\text{V}$
				SY2A55105		$\pm 1$	$\pm 50$	
	Offset Voltage vs Temperature	$dV_{OS}/dT$				0.1	0.5	$\mu\text{V}/^{\circ}\text{C}$
	Offset Voltage vs Power Supply	PSR	$V_{CC} = 3\text{V}$ to $5.5\text{V}$ , $\text{CSP} = 12\text{V}$ , $V_{SENSE} = 0\text{mV}$ , $T_A = 25^{\circ}\text{C}$	SY2A55104		$\pm 0.1$	$\pm 8$	$\mu\text{V}/\text{V}$
SY2A55105					$\pm 0.1$	$\pm 6$		
Input Bias Current	$I_B$	$V_{SENSE} = 0\text{mV}$ , $T_A = 25^{\circ}\text{C}$		30	38	45	$\mu\text{A}$	
Input Offset Current	$I_{OS}$	$V_{SENSE} = 0\text{mV}$ , $T_A = 25^{\circ}\text{C}$			$\pm 0.02$		$\mu\text{A}$	
Output	Gain		SY2A55104		50		V/V	
			SY2A55105		100			
	Gain Error		$V_{SENSE} = -40$ to $40\text{mV}$	SY2A55104		$\pm 0.02\%$	$\pm 0.5\%$	
			$V_{SENSE} = -20$ to $20\text{mV}$	SY2A55105		$\pm 0.02\%$	$\pm 0.5\%$	
	Gain Error vs Temperature					3	10	$\text{ppm}/^{\circ}\text{C}$
Nonlinearity Error		$T_A = 25^{\circ}\text{C}$			$\pm 0.01\%$			
Maximum Capacitive Load		No sustained oscillation, $T_A = 25^{\circ}\text{C}$			1		nF	
Voltage Output	Output-Voltage Swing to $V_{CC}$ Power-Supply Rail		$R_{LOAD} = 10\text{k}\Omega$ to GND			$(V_{CC}) - 0.05$	$(V_{CC}) - 0.2$	V
	Output Voltage Swing to GND		$R_{LOAD} = 10\text{k}\Omega$ to GND			$(V_{GND}) + 0.005$	$(V_{GND}) + 0.05$	V
Frequency Response	Bandwidth	BW	$C_{LOAD} = 10\text{pF}$ , $T_A = 25^{\circ}\text{C}$	SY2A55104		60		kHz
				SY2A55105		28		
	Slew Rate	SR	$T_A = 25^{\circ}\text{C}$			0.4		$\text{V}/\mu\text{s}$
Power Supply	Operation Voltage	$V_{CC}$		3		5.5		V
	Quiescent Current	$I_Q$	$V_{SENSE} = 0\text{mV}$ , $T_A = 25^{\circ}\text{C}$			80	100	$\mu\text{A}$
$V_{SENSE} = 0\text{mV}$						100	$\mu\text{A}$	

**Note 1:** Stresses beyond the “Absolute Maximum Ratings” may cause permanent damage to the device. These are stress ratings only. Functional operation of the device at these or any other conditions beyond those indicated in the operational sections of the specification is not implied. Exposure to absolute maximum rating conditions for extended periods may affect device reliability.

**Note 2:** Package thermal resistance is measured in the natural convection at  $T_A = 25^{\circ}\text{C}$  on an  $8.5\text{cm} \times 8.5\text{cm}$  four-layer Silergy Evaluation Board.

**Note 3:** The device is not guaranteed to function outside its operating conditions.

**Note 4:** RTI = Referred to Input.

## Application Information

The SY2A55104/5 are fixed-gain, zero-drift current-sense amplifiers that monitor current by amplifying the differential voltage across an external shunt resistor to create an output voltage.

The SY2A55104/5 feature a -0.3V to 26V input common-mode range, independent of supply voltage. This ability allows the current to be monitored during short-circuit conditions, while also enabling high-side current sensing above the supply voltage. These devices are intended to operate as analog front ends (AFEs) for analog-to-digital converters (ADCs) or microcontrollers that require high common-mode signal translation to low-side referenced inputs. They are commonly used for overcurrent detection, voltage feedback control loops, or power monitoring.

### REF Input

SY2A55104/5 will measure the voltage developed across a current-sense resistor. The transfer function of SY2A55104/5 is:

$$OUT = Gain \times V_{SENSE} + V_{REF}$$

Where  $V_{SENSE} = V_{CSP} - V_{CSN}$ .

This ability makes the SY2A55104/5 suitable for unidirectional and bidirectional current sensing.

Note that the linear output range of the SY2A55104/5 is 0.05V to  $V_{CC} - 0.2V$ , which means that the output can become will saturate low with a small input signal when the REF pin is connected to ground, and the output can become saturated high with a small input signal when the REF pin is connected to  $V_{CC}$ . In order to achieve a linear response, ensure that the output voltage is between 0.05V and  $V_{CC} - 0.2V$ .

For unidirectional current-sense applications, the REF pin can be connected to ground directly, as shown in Figure 3. When the input signal increases, the output voltage will increase. When very low input currents need to be measured, the REF pin needs to be biased to a convenient value above 50 mV to bring the output into the linear range of the device.

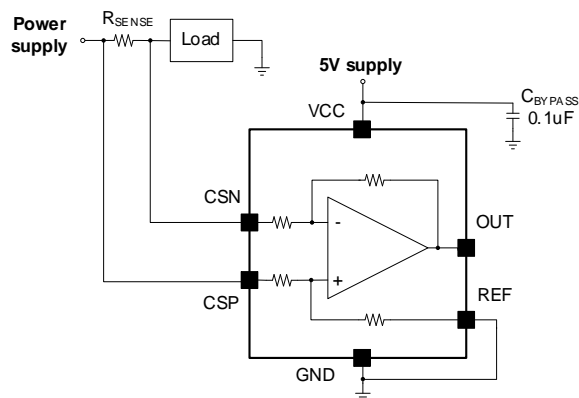

Figure 3. Unidirectional Current-sense Application

For bidirectional current-sense applications, the REF pin can be connected to a reference voltage (for example  $0.5 \times V_{CC}$ ), as shown in Figure 4. The output rises linearly above the reference voltage for positive differential input signals and falls linearly below the reference voltage for negative differential input signals.

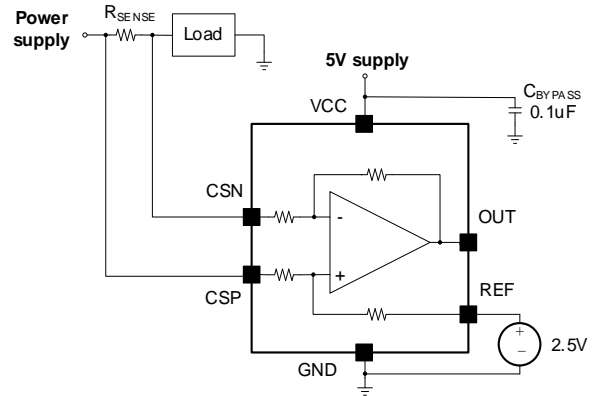

Figure 4. Bidirectional Current-sense Application

Like any differential amplifier, the common-mode rejection ratio of the SY2A55104/5 is affected by the impedance present at the REF input. This problem will not exist when the REF pin is connected directly to most reference or power supplies. When using a resistor-divider from the power supply or a reference voltage, the REF pin must be buffered by an operational amplifier as shown in Figure 5.

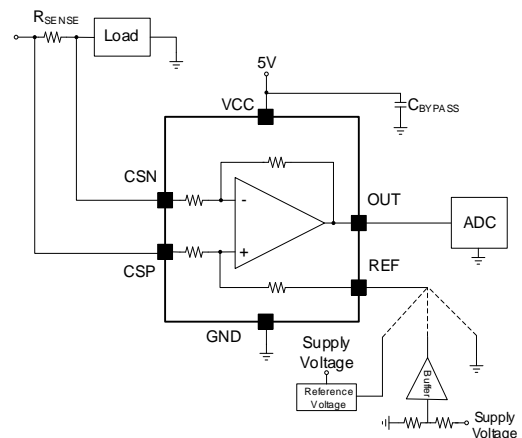

Figure 5. REF Pin Drive

In a system that uses a differential-input ADC or two separate single-ended input ADCs, the differential voltage of the OUT pin and the REF pin of the SY2A55104/5 can be directly connected. This detection method can eliminate the influence of the external impedance on the REF input, where the REF pin can be driven directly with a resistor divider without going through the buffer, as shown in Figure 6.

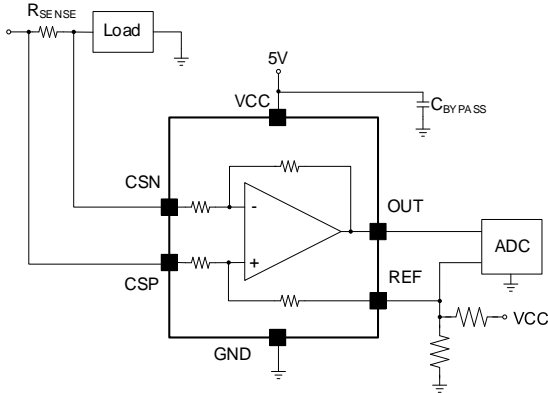

Figure 6. Sensing the SY2A55104/5 to cancel the effects of impedance on the REF input

an internal bias network. When additional external series filter resistors are added to the circuit, a mismatch in the bias currents results in a mismatch of the voltage drop across the filter resistors. This mismatch produces a differential-error voltage that is subtracted from the voltage generated at the shunt resistor, making the voltage generated across the shunt resistor different from the voltage at the input pin of the device. Without additional series resistance, the mismatch of input bias current has little effect on device operation. To reduce the impact on accuracy, the value of these series resistors should be less than 10Ω.

The amount of error that these external filter resistors add to the measurement can be calculated as follows:

$$GainError = \left( \frac{20000}{12.76 \times R_F + 20000} - 1 \right) \times 100\% \quad (\text{for SY2A55104})$$

$$GainError = \left( \frac{10000}{6.88 \times R_F + 10000} - 1 \right) \times 100\% \quad (\text{for SY2A55105})$$

For example, using a  $R_F = 10\Omega$  for external series resistance will result in a gain error of -0.63% (SY2A55104) / -0.68% (SY2A55105).

### Selecting $R_{SENSE}$

The design of the current-sense resistor  $R_{SENSE}$  is dependent on the measured current, the maximum current-sense voltage range between CSP and CSN, the reference voltage  $V_{REF}$ , and the supply voltage  $V_{CC}$ .

For unidirectional current applications, assuming the measured current range is  $0 - I_{maxP}$ , because the maximum current-sense voltage range of the CSP pin and the CSN pin is 1mV–90mV (for SY2A55104) or 1mV–45mV (for SY2A55105), the maximum current-sense resistor  $R_{max1}$  for the input limit is  $90mV / I_{maxP}$  (for SY2A55104) or  $45mV / I_{maxP}$  (for SY2A55105).

Because the output voltage at pin OUT is clamped between GND and  $V_{CC} - 0.2V$ , the maximum current-sense resistor  $R_{max2}$  for the output limit is  $(V_{CC} - 0.2V - V_{REF}) / (50 \times I_{maxP})$  (for SY2A55104) or  $(V_{CC} - 0.2V - V_{REF}) / (100 \times I_{maxP})$  (for SY2A55105).

Choose the smaller value of  $R_{max1}$  and  $R_{max2}$  to be the maximum available current-sense resistor value.

### Input Filtering

To reduce the influence of noise on the sensed power rail and improve the system signal-to-noise ratio (SNR), it's recommended to place a RC filter at the inputs pins, as shown in Figure 7.

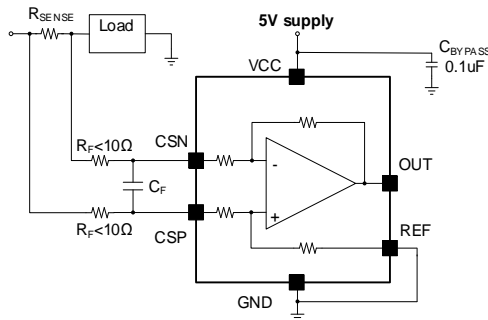

Figure 7. Filter at input pins

Adding external series resistors creates additional errors in the measurement, and using a low value for the resistors is recommended. When differential voltages are applied between the input pins of the SY2A55104/5, there is a mismatch in the input bias currents, which results in

### Unidirectional Application $R_{SENSE}$ Design

Parameter		Range
Measured current range		0A – $I_{maxP}$
Maximum current-sense voltage range	SY2A55104	1mV – 90mV
	SY2A55105	1mV – 45mV
Maximum sensing resistor for input limit	SY2A55104	$R_{max1} = 90mV / I_{maxP}$
	SY2A55105	$R_{max1} = 45mV / I_{maxP}$
Maximum OUT pin output range		GND– $V_{CC} - 0.2V$
Maximum sensing resistor for output limit	SY2A55104	$R_{max2} = (V_{CC} - 0.2V - V_{REF}) / (50 \times I_{maxP})$
	SY2A55105	$R_{max2} = (V_{CC} - 0.2V - V_{REF}) / (100 \times I_{maxP})$
Maximum available current-sense resistor		$R_{SENSE,max} = \text{MIN}[R_{max1}, R_{max2}]$



# SY2A55104/ SY2A55105

For bidirectional current applications, assuming the measured current range is from  $-I_{maxN}$  to  $I_{maxP}$ , the maximum current-sense resistor  $R_{max1}$  for the input limit is the smaller value of  $40mV/I_{maxN}$  and  $40mV/I_{maxP}$  (for SY2A55104), or the smaller value of  $20mV/I_{maxN}$  and  $20mV/I_{maxP}$  (for SY2A55105).

sense resistor  $R_{max2}$  for the output limit is the smaller value of  $V_{REF}/(50 \times I_{maxN})$  and  $(V_{CC} - 0.2V - V_{REF})/(50 \times I_{maxP})$  (for SY2A55104) or the smaller value of  $V_{REF}/(100 \times I_{maxN})$  and  $(V_{CC} - 0.2V - V_{REF})/(100 \times I_{maxP})$  (for SY2A55105).

Choose the smaller value of  $R_{max1}$  and  $R_{max2}$  as the maximum available current-sense resistor value.

Because the output voltage at the OUT pin is clamped between GND and  $V_{CC} - 0.2V$ , the maximum current-

## Bidirectional Application $R_{SENSE}$ Design

Parameter	Range	
Measured current range	$-I_{maxN} - I_{maxP}$	
Maximum current-sense voltage range	SY2A55104	$-40mV - 40mV$
	SY2A55105	$-20mV - 20mV$
Maximum sensing resistor for input limit	SY2A55104	$R_{max1} = \text{MIN}[40mV/I_{maxN}, 40mV/I_{maxP}]$
	SY2A55105	$R_{max1} = \text{MIN}[20mV/I_{maxN}, 20mV/I_{maxP}]$
Maximum OUT pin output range	GND - $V_{CC} - 0.2V$	
Maximum sensing resistor for output limit	SY2A55104	$R_{max2} = \text{MIN}[V_{REF} / (50 \times I_{maxN}), (V_{CC} - 0.2V - V_{REF}) / (50 \times I_{maxP})]$
	SY2A55105	$R_{max2} = \text{MIN}[V_{REF} / (100 \times I_{maxN}), (V_{CC} - 0.2V - V_{REF}) / (100 \times I_{maxP})]$
Maximum available current-sense resistor	$R_{SENSE,max} = \text{MIN}[R_{max1}, R_{max2}]$	

## SY2A55104 $I_{SENSE}$ and $R_{SENSE}$ Design Recommendations

Unidirectional Application ( $V_{REF} = 0V$ )			Bidirectional Application ( $V_{REF} = 0.5 \times V_{CC}$ )		
$I_{SENSE}$ Range	Recommended $R_{SENSE}$		$I_{SENSE}$ Range	Recommended $R_{SENSE}$	
	$V_{CC} = 5V$	$V_{CC} = 3.3V$		$V_{CC} = 5V$	$V_{CC} = 3.3V$
0A-1A	90mΩ	60mΩ	-1A-1A	40mΩ	25mΩ
0A-2A	45mΩ	30mΩ	-2A-2A	20mΩ	14mΩ
0A-3A	30mΩ	20mΩ	-4A-4A	10mΩ	7mΩ
0A-5A	18mΩ	12mΩ	-5A-5A	8mΩ	5mΩ
0A-10A	9mΩ	6mΩ	-10A-10A	4mΩ	2.5mΩ

## SY2A55105 $I_{SENSE}$ and $R_{SENSE}$ Design Recommendations

Unidirectional Application ( $V_{REF} = 0V$ )			Bidirectional Application ( $V_{REF} = 0.5 \times V_{CC}$ )		
$I_{SENSE}$ Range	Recommended $R_{SENSE}$		$I_{SENSE}$ Range	Recommended $R_{SENSE}$	
	$V_{CC} = 5V$	$V_{CC} = 3.3V$		$V_{CC} = 5V$	$V_{CC} = 3.3V$
0A-1A	45mΩ	30mΩ	-1A-1A	20mΩ	14mΩ
0A-2A	22.5mΩ	15mΩ	-2A-2A	10mΩ	7mΩ
0A-3A	15mΩ	10mΩ	-4A-4A	5mΩ	3.5mΩ
0A-5A	9mΩ	6mΩ	-5A-5A	4mΩ	2.5mΩ
0A-10A	4.5mΩ	3mΩ	-10A-10A	2mΩ	1.4mΩ

## Application Schematic

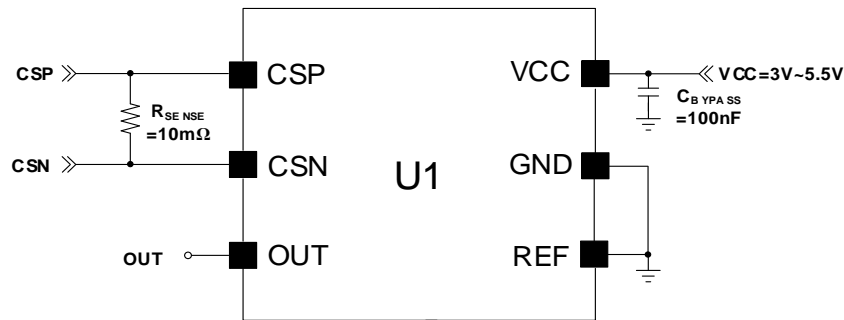

## BOM List

Reference Designator	Description	Part Number	Manufacturer
C <sub>BYPASS</sub>	100nF/50V/X7R, 0603	GCJ188R71H104KA12D	muRata
R <sub>SENSE</sub>	10mΩ/1W, 2512, 1%	RL2512FK-070R01L	YAGEO

## Layout Design

For optimal design, follow these PCB layout considerations:

- Use a Kelvin connection to connect the input pins to the current-sense resistor  $R_{SENSE}$ . Due to the low resistance values of  $R_{SENSE}$ , poor PCB routing often leads to additional parasitic resistance between input pins, resulting in additional errors that cannot be ignored. The Kelvin connection technique ensures that only  $R_{SENSE}$  impedance is detected between the input pins. Minimize the loop area formed by these connections.
- Use a 0.1μF MLCC bypass capacitor, placed as close as possible to  $V_{CC}$  and GND.

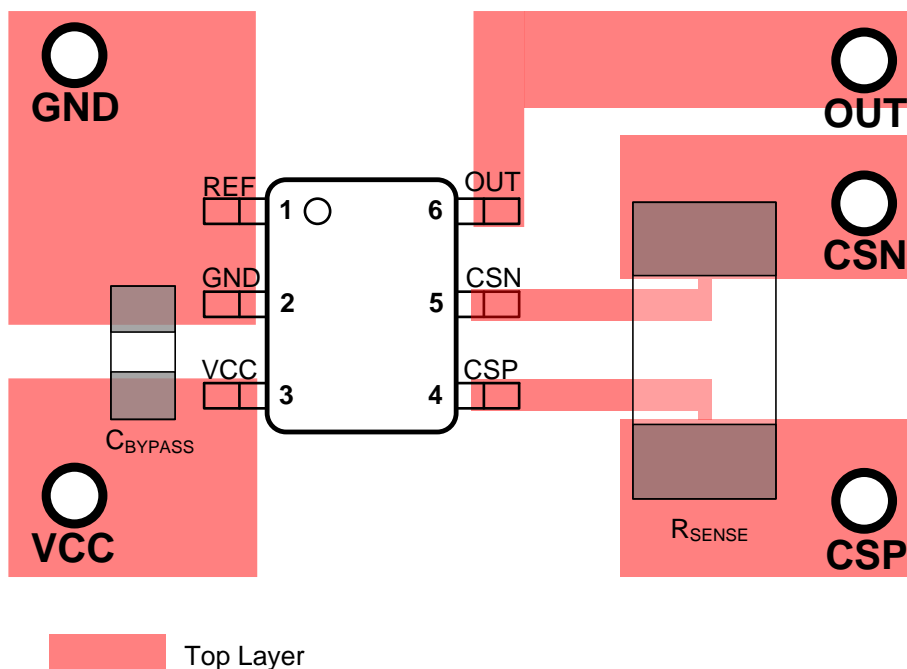
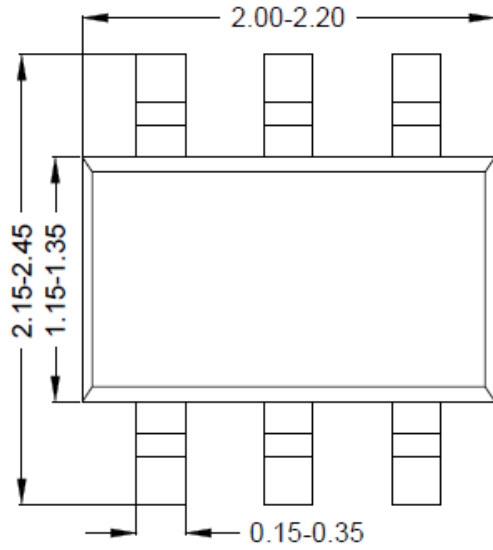
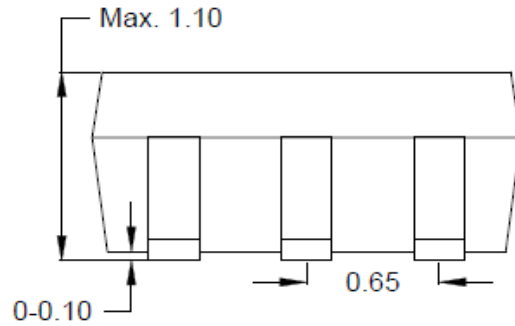

Figure 8. Recommended Layout

## SOT363 Package Outline Drawing



Top view



Side view A

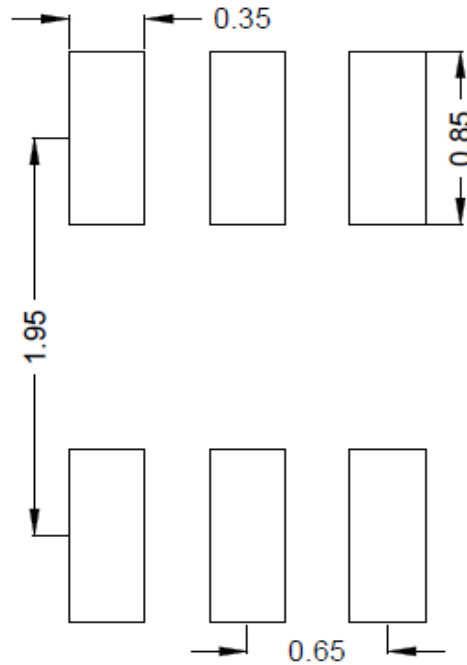

Recommended PCB layout  
(Reference only)

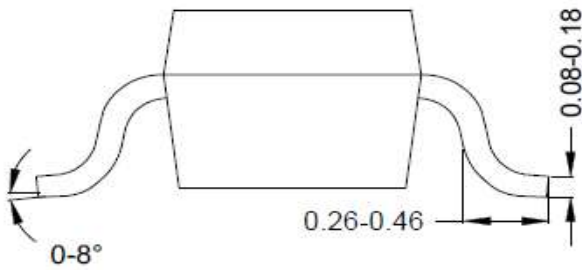

Side view B

**Note:** All dimensions are in millimeters and exclude mold flash and metal burr.

## Taping and Reel Specification

### Package Orientation

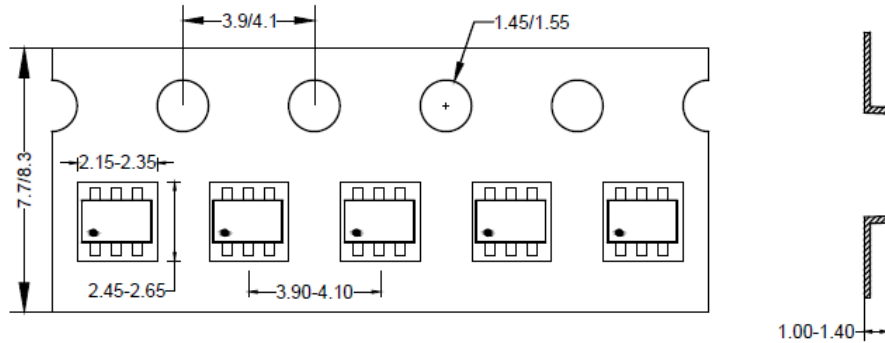

Feeding direction

### Carrier Tape and Reel Specification for Packages

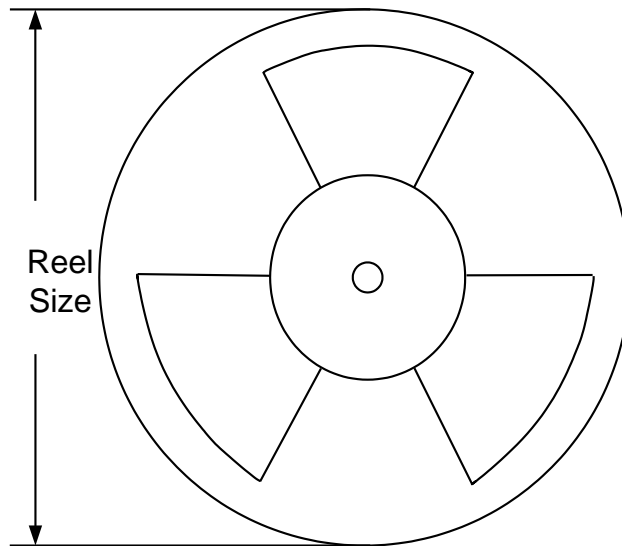

Package types	Tape width (mm)	Pocket pitch(mm)	Reel size (Inch)	Trailer length(mm)	Leader length (mm)	Qty per reel
SOT363	8	4	7"	280	160	3000

Others: NA



## Revision History

The revision history provided is for informational purpose only and is believed to be accurate, however, not warranted. Please make sure that you have the latest revision.

<b>Date</b>	<b>Revision</b>	<b>Change</b>
Dec. 10, 2021	Revision 0.9	Initial Release.
Dec. 10, 2022	Revision 1.0	Production Release.



## IMPORTANT NOTICE

- 1. Right to make changes.** Silergy and its subsidiaries (hereafter Silergy) reserve the right to change any information published in this document, including but not limited to circuitry, specification and/or product design, manufacturing or descriptions, at any time and without notice. This document supersedes and replaces all information supplied prior to the publication hereof. Buyers should obtain the latest relevant information before placing orders and should verify that such information is current and complete. All semiconductor products are sold subject to Silergy's standard terms and conditions of sale.
- 2. Applications.** Application examples that are described herein for any of these products are for illustrative purposes only. Silergy makes no representation or warranty that such applications will be suitable for the specified use without further testing or modification. Buyers are responsible for the design and operation of their applications and products using Silergy products. Silergy or its subsidiaries assume no liability for any application assistance or designs of customer products. It is customer's sole responsibility to determine whether the Silergy product is suitable and fit for the customer's applications and products planned. To minimize the risks associated with customer's products and applications, customer should provide adequate design and operating safeguards. Customer represents and agrees that it has all the necessary expertise to create and implement safeguards which anticipate dangerous consequences of failures, monitor failures and their consequences, lessen the likelihood of failures that might cause harm and take appropriate remedial actions. Silergy assumes no liability related to any default, damage, costs or problem in the customer's applications or products, or the application or use by customer's third-party buyers. Customer will fully indemnify Silergy, its subsidiaries, and their representatives against any damages arising out of the use of any Silergy components in safety-critical applications. It is also buyers' sole responsibility to warrant and guarantee that any intellectual property rights of a third party are not infringed upon when integrating Silergy products into any application. Silergy assumes no responsibility for any said applications or for any use of any circuitry other than circuitry entirely embodied in a Silergy product.
- 3. Limited warranty and liability.** Information furnished by Silergy in this document is believed to be accurate and reliable. However, Silergy makes no representation or warranty, expressed or implied, as to the accuracy or completeness of such information and shall have no liability for the consequences of use of such information. In no event shall Silergy be liable for any indirect, incidental, punitive, special or consequential damages, including but not limited to lost profits, lost savings, business interruption, costs related to the removal or replacement of any products or rework charges, whether or not such damages are based on tort or negligence, warranty, breach of contract or any other legal theory. Notwithstanding any damages that customer might incur for any reason whatsoever, Silergy' aggregate and cumulative liability towards customer for the products described herein shall be limited in accordance with the Standard Terms and Conditions of Sale of Silergy.
- 4. Suitability for use.** Customer acknowledges and agrees that it is solely responsible for compliance with all legal, regulatory and safety-related requirements concerning its products, and any use of Silergy components in its applications, notwithstanding any applications-related information or support that may be provided by Silergy. Silergy products are not designed, authorized or warranted to be suitable for use in life support, life-critical or safety-critical systems or equipment, nor in applications where failure or malfunction of an Silergy product can reasonably be expected to result in personal injury, death or severe property or environmental damage. Silergy assumes no liability for inclusion and/or use of Silergy products in such equipment or applications and therefore such inclusion and/or use is at the customer's own risk.
- 5. Terms and conditions of commercial sale.** Silergy products are sold subject to the standard terms and conditions of commercial sale, as published at <http://www.silergy.com/stdterms>, unless otherwise agreed in a valid written individual agreement specifically agreed to in writing by an authorized officer of Silergy. In case an individual agreement is concluded only the terms and conditions of the respective agreement shall apply. Silergy hereby expressly objects to and denies the application of any customer's general terms and conditions with regard to the purchase of Silergy products by the customer.
- 6. No offer to sell or license.** Nothing in this document may be interpreted or construed as an offer to sell products that is open for acceptance or the grant, conveyance or implication of any license under any copyrights, patents or other industrial or intellectual property rights. Silergy makes no representation or warranty that any license, either express or implied, is granted under any patent right, copyright, mask work right, or other intellectual property right. Information published by Silergy regarding third-party products or services does not constitute a license to use such products or services or a warranty or endorsement thereof. Use of such information may require a license from a third party under the patents or other intellectual property of the third party, or a license from Silergy under the patents or other intellectual property of Silergy.

For more information, please visit: [www.silergy.com](http://www.silergy.com)

© 2023 Silergy Corp.

All Rights Reserved.