

General Description

The SY24656 which has an I²C or SMBUS-compatible interface, is a high accuracy device with the features of current shunt, bus voltage and power monitor.

The shunt voltage and the bus supply voltage could be sampled accurately at the same time and will be processed inside the device to generate the power data with programmable calibration, averaging technique and internal multiplier. It makes the application system more reliable because of abundant alert sources settings provided by programmable alert function.

The current on common mode bus voltages can be monitored by SY24656. The common mode bus voltages can vary from 0V to 36V, which is independent of the supply voltage, ranging from 2.7V to 5.5V. The operating temperature of SY24656 ranges between -40°C and +125°C. The SY24656 is available in the MSOP-10 package and features 16 programmable addresses on the I²C-compatible interface.

Features

- Senses Bus Voltages from 0 V to 36 V
- High-Side or Low-Side Sensing
- Bi-directional Current Sensing
- Reports Current, Voltage, and Power
- High Accuracy:
 - 0.02% Gain Error (Typ) for Shunt Voltage
 - 0.02% Gain Error (Typ) for Bus Voltage
 - 2.5μV Offset (Typ) for Shunt Voltage
 - 1.25mV Offset (Typ) for Bus Voltage
- Configurable Averaging Options
- Configurable Conversion Time
- Abundant Alert Sources Setting
- 16 Programmable Addresses
- High Speed I²C Mode Compatible
- Operates from 2.7V to 5.5V Power Supply

Applications

- Servers
- Telecom Equipment
- Computing
- Power Management
- Battery Chargers
- Power Supplies
- Test Equipment

Typical Application

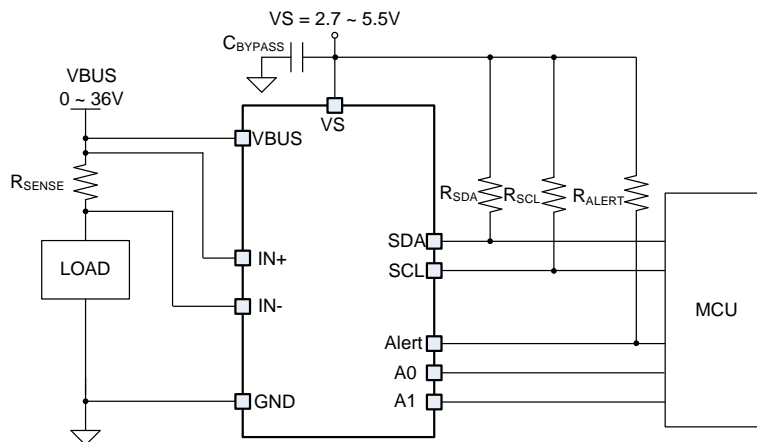

Figure 1. Typical Application

Ordering Information

Ordering Part Number	Package type	Top Mark
SY24656FBC	MSOP10 RoHS Compliant and Halogen Free	CXExyz

x=year code, y=week code, z=lot number code

Pinout (Top View)

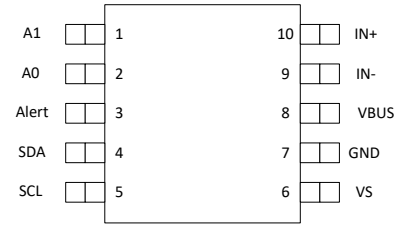

(MSOP10)

Pin Description

Pin No	Pin Name	Pin Description
1	A1	Address pin. Connect to GND, SCL, SDA, or VS.
2	A0	Address pin. Connect to GND, SCL, SDA, or VS.
3	Alert	Multi-functional alert, open-drain output.
4	SDA	Serial bus data line, open-drain input/output.
5	SCL	Serial bus clock line, open-drain input.
6	VS	Power supply, 2.7 V to 5.5 V.
7	GND	Ground.
8	VBUS	Bus voltage input.
9	IN-	Negative differential voltage input. Connect to load side of shunt resistor.
10	IN+	Positive differential voltage input. Connect to supply side of shunt resistor.

Block Diagram

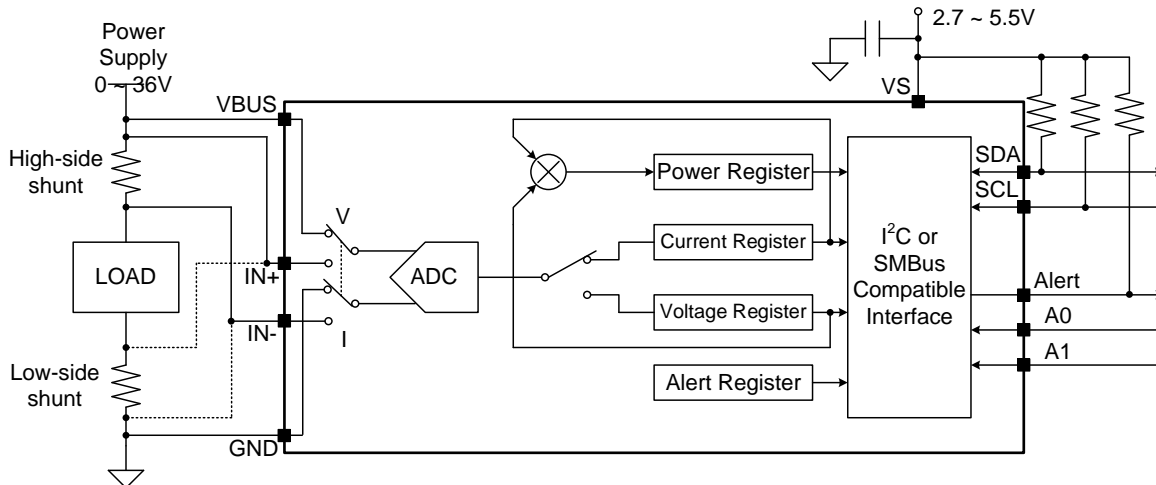

Figure 2. Block Diagram

Absolute Maximum Ratings

Parameter (Note 1)	Min	Max	Unit
VS	-0.3	6	V
Differential Analog input ($V_{IN+} - V_{IN-}$)	-40	40	
Common Mode Analog input ($(V_{IN+} + V_{IN-}) / 2$)	-0.3	40	
BUS	-0.3	40	
SDA, ALERT	-0.3	6	
SCL, A0, A1	-0.3	VS+0.3	
Input current into any pin		5	mA
Open-drain digital output current (SDA, SCL, ALERT)		10	
Junction Temperature, Operating	-40	150	°C
Storage Temperature	-65	150	
ESD: HBM (Human Body Mode)	± 2000		V
ESD: CDM (Charged Device Model)	± 1000		V

Thermal Information

Parameter (Note 2)	Max	Unit
θ_{JA} Junction-to-ambient Thermal Resistance	136	°C/W
θ_{JC} Junction-to-case Thermal Resistance	25	
P_D Power Dissipation $T_A = 25^\circ\text{C}$	0.74	W

Recommended Operating Conditions

Parameter (Note 3)	Min	Max	Unit
VS	2.7	5.5	V
Differential Analog input ($V_{IN+} - V_{IN-}$)	-81.92	+81.917	mV
Common Mode Analog input ($(V_{IN+} + V_{IN-}) / 2$)	0	36	
BUS	0	36	V
Junction Temperature Range	-40	125	°C

Electrical Characteristics

$V_S = 3.3V$, $V_{IN+} = 12V$, $V_{SENSE} = (V_{IN+} - V_{IN-}) = 0mV$ and $V_{VBUS} = 12V$, $T_A = 25^\circ C$, unless otherwise specified. (4)

Parameter(4)	Symbol	Test condition	Min	Typ	Max	Unit	
Input	Shunt Voltage Input Range		-81.92		+81.917 5	mV	
	Bus Voltage Input Range (Note 5)		0		36	V	
	Common-Mode Rejection	CMRR	$0V \leq V_{IN+} \leq 36V$	126	140		dB
	Shunt Offset Voltage, RTI (Note 6)	V_{OS}			± 2.5	± 10	μV
	Shunt Offset Voltage, RTI vs. Temperature		$-40^\circ C \leq T_A \leq 125^\circ C$		0.02	0.1	$\mu V/^\circ C$
	Shunt Offset Voltage, RTI vs. Power Supply	PSRR	$2.7V \leq V_S \leq 5.5V$		2.5		$\mu V/V$
	Bus Offset Voltage, RTI	V_{OS}			± 1.25	± 7.5	mV
	Bus Offset Voltage, RTI vs. Temperature		$-40^\circ C \leq T_A \leq 125^\circ C$		10	40	$\mu V/^\circ C$
	Bus Offset Voltage, RTI vs. Power Supply	PSRR			0.5		mV/V
	Input Bias Current (I_{IN+} , I_{IN})	I_B			7		μA
	VBUS Input Impedance				830		k Ω
	Input Leakage (Note 7)		(IN+ pin) + (IN- pin), Power-down mode		0.1	0.5	μA
DC Accuracy	ADC Native Resolution			16		Bits	
	1 LSB Step Size		Shunt voltage		2.5		μV
			Bus voltage		1.25		mV
	Shunt Voltage Gain Error			0.02	0.15	%	
	Shunt Voltage Gain Error vs. Temperature		$-40^\circ C \leq T_A \leq 125^\circ C$		10	50	ppm/ $^\circ C$
	Bus Voltage Gain Error				0.02	0.2	%
	Bus Voltage Gain Error vs. Temperature		$-40^\circ C \leq T_A \leq 125^\circ C$		10	50	ppm/ $^\circ C$
	Differential Nonlinearity				± 0.1		LSB
	ADC Conversion Time	t_{CT}	CT bit = 000		140	165	μs
			CT bit = 001		204	232	
CT bit = 010				332	366		
CT bit = 011				588	633		
CT bit = 100				1.1	1.165	ms	
CT bit = 101				2.116	2.224		
CT bit = 110				4.156	4.349		
		CT bit = 111		8.244	8.608		
SMBus	SMBus Timeout (Note 8)			28	35	ms	
Digital Input/Output	Input Capacitance			3		pF	
	Leakage Input Current		$0V \leq V_{SCL} \leq V_S$, $0V \leq V_{SDA} \leq V_S$, $0V \leq V_{Alert} \leq V_S$, $0V \leq V_{A0} \leq V_S$, $0V \leq V_{A1} \leq V_S$		0.1	1	μA
	High Level Input Voltage	V_{IH}		$0.7 \times V_S$		6	V
	Low Level Input Voltage	V_{IL}		-0.5		$0.3 \times V_S$	V
	Low Level Output Voltage, SDA, Alert	V_{OL}	$I_{OL} = 3mA$		0	0.4	V
	Hysteresis				400		mV
Power Supply	Operating Supply Range		2.7		5.5	V	
	Quiescent Current	I_Q			396	460	μA
			Power mode down (shutdown)		0.5	1	
Power-on Reset Threshold	V_{POR}			2		V	

Note 1: Stresses beyond the “Absolute Maximum Ratings” may cause permanent damage to the device. These are stress ratings only. Functional operation of the device at these or any other conditions beyond those indicated in the operational sections of the specification is not implied. Exposure to absolute maximum rating conditions for extended periods may affect device reliability.

Note 2: Package thermal resistance is measured in the natural convection at $T_A=25^{\circ}\text{C}$ on an 8.5cm×8.5cm size four-layer Silergy Evaluation Board.

Note 3: The device is not guaranteed to function outside its operating conditions.

Note 4: Production testing is performed at 25°C ; limits at -40°C to $+125^{\circ}\text{C}$ are guaranteed by design, test or statistical correlation.

Note 5: While the input range is 36 V, the full-scale range of the ADC scaling is 40.96 V. Do not apply more than 36 V.

Note 6: RTI = Referred-to-input.

Note 7: Input leakage is positive (current flowing into the pin) for the conditions shown at the top of this table. Negative leakage currents can occur under different input conditions.

Note 8: SMBus timeout in the SY24656 resets the interface any time SCL is low for more than 28ms.

Detailed Description

Bus Voltage and Current Sample

The bus voltage and shunt voltage could be measured directly on the power supply bus of interest in the SY24656. The power supply bus voltage can be taken at the VBUS pin, while the shunt voltage representing the current is measured by the IN+ and IN– pins. The differential shunt voltage is measured with respect to the IN– pin while the bus voltage and the shunt voltage are measured with respect to ground and IN– pin, respectively.

Operation Mode

The continuous and triggered operating modes for data conversions in the device will determine how the ADC operates following these conversions.

Continuous Operating Mode:

The continuous operating mode of the SY24656 will be adopted as the MODE bits of the Configuration Register (00h) are set to '111'. At first, the number of averages should be set in the Configuration Register. The shunt voltage and then the bus voltage will be sampled and converted in each sampling sequence. Next, the current value is calculated based on the shunt voltage to get the power result. All the values will be stored in an accumulator and the above measurement/calculation sequence repeats until the number of averages set in the Configuration Register is reached. At the end of each sequence, the newly acquired set of values is added to previously gathered values. When all the averaging finishes, the final values of shunt voltage, bus voltage, current, and power will be renewed in the corresponding registers, which could read without any affect by the conversion in progress. These values will be covered when another fully completed conversion results is stored in the same register.

All the calculations are performed in the background, which has no influence on conversion time.

The shunt voltage or the bus voltage can be converted solely with proper setting by the mode control in the Conversion Register (00h) to fit the user's explicit application conditions.

Triggered Operating Mode:

The triggered mode of the SY24656 will be adopted as the MODE bits of the Configuration Register (00h) are set to '001', '010', or '011'. A single-shot conversion will be fulfilled to produce a single set of measurements as any triggered convert modes are wrote into the Configuration Register. Thus, another single-shot conversion can be only executed under the condition that the Configuration Register is written to a second time, even if the mode does not change.

Power-Down Mode:

Furthermore, the power-down mode of the SY24656 is designed to reduce the quiescent current and turn off current into the device inputs, which can reduce impact of supply drain when the device is not being used. During the power-down mode, the values in the registers can be replaced and read. The power-down mode will exit with any active mode settings written into the Configuration Register. Notes: The exit procedures need 40 μ s.

Conversion Ready Flag

To help coordinate one-shot or triggered conversions, the Conversion Ready flag bit (CVRF bit, Mask/Enable Register) is provided, though the SY24656 can be read at any time, and the data from the last conversion remain available. The CVRF bit will be set after the completion of all conversions, averaging, and multiplication operations. The Conversion Ready flag (CVRF) bit clears under these conditions:

- Writing to the Configuration Register (00h) , except when configuring the MODE bits for power-down mode.
- Reading the Mask/Enable Register (06h)

Averaging and Conversion Time

The conversion times (t_{CT}) for both the shunt voltage and bus voltage measurements can be selected from as fast as 140 μ s to as long as 8.244ms independently. This way is useful in applications because the bus voltage tends to be quite stable. This setting makes sure that more time will be adopted to measure the shunt voltage rather than the bus voltage.

There is a compromise between the settings for conversion time and the used averaging mode. The averaging feature could effectively filter the signal, resulting in dramatic modification of the measurement accuracy. Any kind of noise, even if it is coupled into the signal, could be suppressed by employing this approach in the device. With a vast average, the device could get more accurate signals by suppressing the noise.

The measured shunt voltage will be compared with the Alert Limit Register following every shunt voltage conversion and assert the AFF bit and Alert pin if the limit threshold is overtaken.

The measured bus voltage will be compared with the Alert Limit Register following every bus voltage conversion and assert the AFF bit and Alert pin if the limit threshold is overtaken.

The calculated power value will also be compared following every bus voltage measurement conversion and asserts the AFF bit and Alert pin if the limit threshold is overtaken.

For instance, if the alert function of Current Over-Limit (COL) is enabled, when each shunt voltage conversion is completed, the measured value will be compared to the value programmed in the Alert Limit Register to determine whether the sampled has overtaken the set limit. Once the measured value overtakes the programmed one in the Alert Limit Register, the AFF, bit 4 of the Mask/Enable Register, will assert high. Except for the AFF being asserted, the Alert Polarity Bit (APOL, bit 1 of the Mask/Enable Register) can also make the alert pin assert. If the Alert Latch is enabled, the AFF and Alert pin will remain asserted until either the Mask/Enable Register is read or the Configuration Register (00h) is written to. 0h) is written to or the Mask/Enable Register is read.

If the Alert pin is not used in a design, it can be left floating.

Device Configuration

In order to report the current and power values properly, several registers should be configured using the following steps:

Step1: select the resolution of the Current Register (04h): Current_LSB.

The user can obtain the highest resolution for Current Register (04h) by adopting the smallest allowable Current_LSB based on the maximum expected current I_{MAX} as shown in Equation (1). Select a value for the Current_LSB to the nearest round number above this value to obtain the conversion of the Current Register (04h) and Power Register (03h) to amperes and watts respectively.

$$Current_LSB = \frac{I_{MAX}}{2^{15}} \quad (1)$$

Where Current_LSB is the resolution of the Current Register (04h); I_{MAX} is the maximum expected current.

Moreover, this value of the shunt resistor is selected based on the shunt voltage measurement range and I_{MAX}.

Step2: configure the Calibration Register (05h)

The Calibration Register enables the user to scale the Current Register (04h) and Power Register (03h) values. With the correct configuration of the Calibration Register (05h), the current flowing through the shunt resistor can be read out by simply multiply the Current Register and Current_LSB. The value of the Calibration Register (05h), CAL[R], can be calculated using the equation (2) below:

$$CAL[R] = \frac{2048 \times Shunt_LSB}{Current_LSB \times R_{Shunt}} \quad (2)$$

Where CAL[R] is the value of the Calibration Register (05h), Shunt_LSB is the resolution of the Shunt Voltage Register (01h), Shunt_LSB is 2.5uV/LSB; Current_LSB is the resolution of the Current Register (04h); R_{Shunt} is the shunt resistor.

After programming the Calibration Register, the Current Register (04h) and Power Register (03h) will update accordingly based on the corresponding shunt voltage and bus voltage measurements on every measurement cycle. Before programming the Calibration Register, the Power Register (03h) and Current Register (04h) keeps at zero.

Step3: Current Register (04h)

The value of the Shunt Register (01h) can be calculated using the equation (3)

$$Shunt[R] = \frac{Current \times R_{Shunt}}{Shunt_LSB} \quad (3)$$

In the device, based on the value in Calibration Register(05h) and the Shunt Voltage Register (01h), the Current Register value is calculated as shown in the equation (4).

$$Current[R] = \frac{Shunt[R] \times CAL[R]}{2048} \quad (4)$$

Where Current[R] is the value of the Current Register (04h); Shunt[R] is the value of the Shunt Register (01h); CAL[R] is the value of the Calibration Register (05h)

The Current Register value represents the current in Amperes as described by the equation (5)

$$Current = Current[R] \times Current_LSB \quad (5)$$

Step4: Bus Voltage Register

The bus voltage is read by the equation (6)

$$Bus = Bus[R] \times Bus_LSB \quad (6)$$

Where Bus_LSB is the resolution of the Bus Voltage Register(02h), which is a fixed 1.25mV/LSB.

Step5: Power Register

The value of the Power Register (03h) is calculated according the equation (7)

$$Power[R] = \frac{Current[R] \times Bus[R]}{20000} \quad (7)$$

Where Current[R] is the value of the Current Register (04h); Bus[R] is the value of the Bus Voltage Register (02h); Power[R] is the value of the Power Register(03h).

Based on equations (1)~(7), the resolution of the Power Register is fixed as 25 times of the resolution of the Current Register. The resulting power value obtained based on equation (8)

$$Power = Power[R] \times Power_LSB \quad (8)$$

Configuration Example

In Figure4, a nominal 10A load creates a differential voltage of 20mV across a 2mΩ shunt resistor. In this example, the external VBUS input pin is used to measure the bus voltage in the SY24656. In order to measure the voltage level delivered to the load, the IN–pin is connected to the external VBUS input pin. In this example, the VBUS pin measures less than 12 V because the voltage at the IN– pin is 11.98 V as a result of the voltage drop across the shunt resistor.

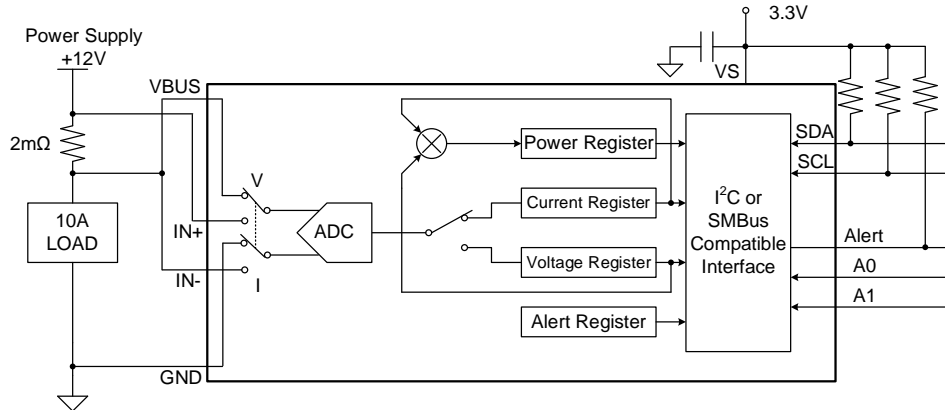

Figure 4. High-Side Sensing Circuit Application Example

Assuming a maximum expected current of 15A, the Current_LSB is calculated to be 457.7μA/bit using Equation (1). The Current_LSB value could be rounded up to 500μA/Bit or 1mA/Bit, to simplify the conversion from the Current Register (04h) and Power Register (03h) to amperes and watts. As for this example, the value of 1mA/bit was used for the Current_LSB. Using this value for the Current_LSB will significantly simplify the conversion process on the user side with trading a small amount of resolution. Using the equation (2) with a Current_LSB value of 1mA/bit and a shunt resistor value of 2mΩ results in a Calibration Register value of 2560 (A00h).

As shown in Equation (4), the Current Register (04h) is calculated by multiplying the value of the Shunt Voltage Register (01h) contents by the value of the Calibration Register and then dividing by 2048. It is noted that the values of the Shunt Voltage Register (01h) and the Calibration Register are decimal numbers. As for this example, the value for the Current Register (04h) of 10000 (decimal value), or 2710h can be obtained by multiplying the Shunt Voltage Register value of 8,000 (representing 20mV) by the Calibration Register value of 2560 and then divided by 2048. Multiplying this value by 1mA/bit results in the original 10A current level to be measured.

The 11.98V in the VBUS pin results in a decimal value of 9584 and a register equivalent of 2570h because of a fixed 1.25mV/bit in the LSB for the Bus Voltage Register (02h). Significantly, the VBUS pin cannot measure negative voltage, so the MSB of the Bus Voltage Register (02h) is invariably zero.

As defined in Equation (7), the Power Register (03h) can be calculated as follow: firstly, multiply the value of the Current Register, 10000 (decimal value) by the value of the Bus Voltage Register (02h), 9584 (decimal value); next, the front result is divided by 20,000. As a result, the value for the Power Register (03h) is 4792 (decimal value) or 12B8h. A power calculation of (4792 × 25mW/bit), or 119.82W is the result of multiplying the value for the Power Register (03h) by the power LSB (25 times Current LSB). A fixed ratio of 25 between the power LSB and Current LSB is internally programmed

to ensure that the power calculation is just in an acceptable range. As for this example, the Current_LSB of 1mA/bit results in a power LSB of 25mW/bit. A simple calculation for the power on the load could use the load current of 10A multiplied by the bus voltage of 11.98V to get a result of 119.8W.

Table 1 lists the results of the values for current and power for the SY24656 at the condition of Load = 10 A, $V_{CM}=12V$, $R_{SHUNT}=2m\Omega$, and $V_{VBUS}=12V$.

Table 1. Calculating Current and Power

Register Name	Address	Contents	Dec	Lsb	Value
Configuration Register	00h	4127h			
Shunt Register	01h	1F40h	8000	2.5 μ V	20mV
Bus Voltage Register	02h	2570h	9584	1.25mV	11.98V
Calibration Register	05h	0A00h	2560		
Current Register	04h	2710h	10000	1mA	10A
Power Register	03h	12B8h	4792	25mW	119.82W

Simple Monitor Usage

If only reading a shunt voltage drop and bus voltage on the condition of the default power-on reset configuration and continuous conversion of shunt and bus voltages, the user can use the device with no programming.

Notably, not only a valid current but also a power value cannot be provided by the device, with no programming in the Calibration Register. This is because that these outputs are generated by the values loaded into the Calibration Register.

Basic I²C/SMBus Overview

The SY24656 is compatible with I²C and SMBus interfaces. There are two lines, SCL and SDA, connecting the device to the bus, which are open-drain connections.

A master is the device that initiates a data transfer. The slaves are the devices controlled by the master. A master device will control the bus to generate the serial clock (SCL), control the bus access and generate START and STOP conditions.

In order to address a given device, a start condition will be initiated by the master though pulling the data signal line (SDA) from a high to a low logic level when SCL is high. On the rising edge of SCL, all slaves on the bus shift in the slave address byte, where the last bit indicates whether a read or write operation is intended. The addressed slaves respond to the master by producing an Acknowledge and pulling SDA low during the ninth clock pulse.

After an Acknowledge bit, data transfer will be initiated and eight of data will be sent. The most significant byte of the Register bytes is sent firstly and followed by the least significant byte. SDA must keep stable during data transfer with SCL high. Any change in SDA with SCL high will be regard as a start or stop condition.

With all data transmission finished, a stop condition is generated by the master with the symptom of pulling SDA from low to high keeping SCL high. To prevent locking up the bus, a 28ms timeout on the interface of the device is involved.

The SY24656 supports fast mode (1kHz to 400kHz) and high-speed mode (1kHz to 3.4MHz) transmission protocols. All data transmitted are most significant byte first.

Programming

Serial Bus Address

To communicate with multiple devices on the bus, SY24656 has 16 programmable slave addresses, which consists of seven address bits and a function bit that determines read or write operation.

The programmable address is determined by two address pins, A0 and A1. The following table lists the corresponding relationship between pins and addresses. The device samples the state of pins A0 and A1 on every bus communication. Establish the pin states before any activity on the interface occurs.

Table 2. Address Pins and Slave Addresses

A1	A0	Slave Address
GND	GND	1000000
GND	VS	1000001
GND	SDA	1000010
GND	SCL	1000011
VS	GND	1000100
VS	VS	1000101
VS	SDA	1000110
VS	SCL	1000111
SDA	GND	1001000
SDA	VS	1001001
SDA	SDA	1001010
SDA	SCL	1001011
SCL	GND	1001100
SCL	VS	1001101
SCL	SDA	1001110
SCL	SCL	1001111

Writing Command

To access a specific register on SY24656 the user should write an appropriate value to the register pointer. The first byte transferred after the slave address byte is the value for the register pointer while the R/W bit is low. A value for the register pointer is desired to the device for each write operation.

As the master transmits the first byte, which is the slave address with R/W bit low, writing to a register will start. Then the receipt of a valid address is acknowledged by the device. The master transmits the next byte, which is the address of the register, where the data is written. The register pointer to the desired register is updated by this register address. The next two bytes are written to the register addressed by the register pointer. The receipt of each data byte is acknowledged by the device. The data transfer may be terminated as a start or stop condition is generated by the master.

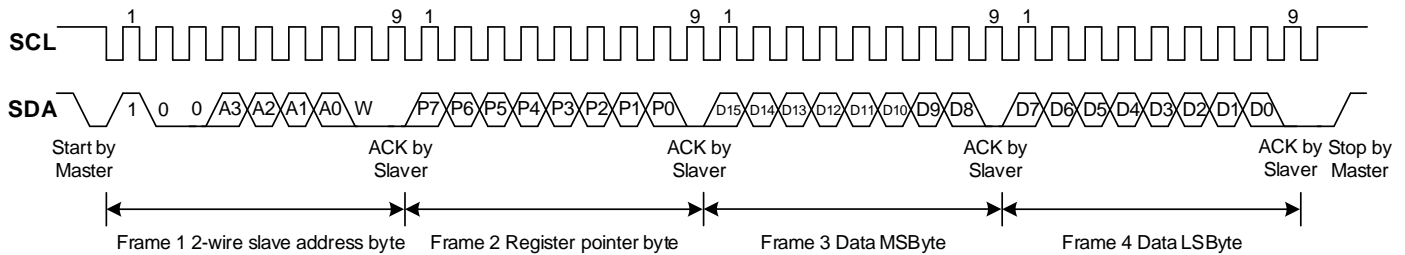

Figure 5. Timing Diagram for Write Word Format

Read Command

When reading from SY24656 the register pointer must be rewritten, as shown in Figure 6. This write is alone with sending the salve address byte while the R/W bit is low, followed by the register pointer byte. No other data are needed.

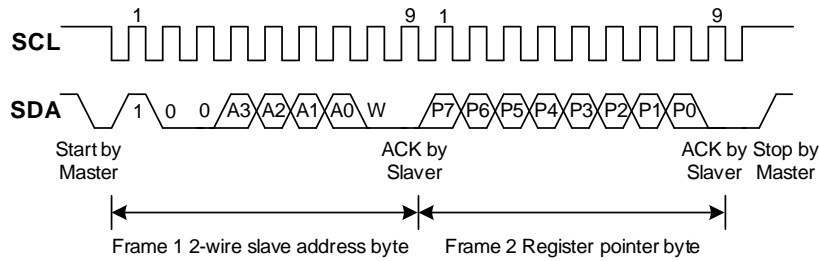

Figure 6. Typical Register Pointer Set

To initiate the read command, a start condition is generated and the slave address byte is sent by the master, while the R/W bit is high. And then the slave transmits the most significant byte of the register indicated by the register pointer, which is followed by an Acknowledge from the master; the last byte is the least significant byte transmitted by slave. The receipt of the data byte is acknowledged by the master. The data transfer may be terminated as a Not-Acknowledge after receiving any data byte, or a start or stop condition is generated by the master.

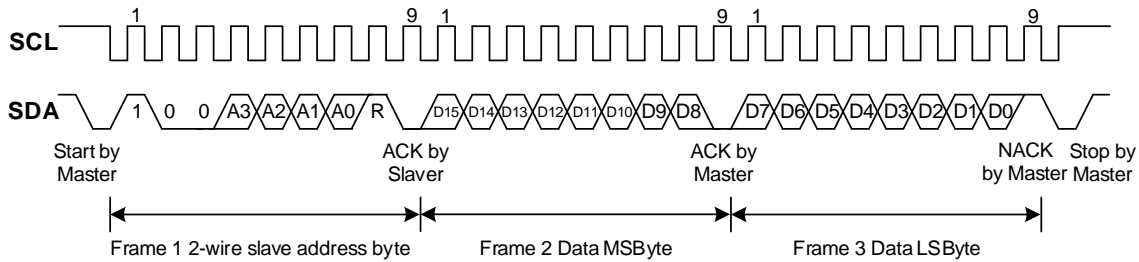

Figure 7. Timing Diagram for Read Word Format

High-Speed I²C Mode

The pull-up resistors will pull high the SDA and SCL lines, if the bus is free. A start condition is generated by the master followed by a valid serial byte, which contains high-speed (HS) master code 00001XXX. In both fast (400kHz) or standard (100kHz) (F/S) mode, this transmission can be executed at no more than 400kHz. The device does recognize the HS master code and switches its internal filters to support 3.4MHz operation, even if no HS master code is acknowledged.

A repeated start condition, which has the same timing as the start condition, is then generated by the master. After this repeated start condition, the protocol is almost identical to F/S mode while the transmission speeds cannot be up to 3.4MHz. Rather than a stop condition, the use of the repeated start conditions could repeated start conditions. The stop condition could escape the HS-mode and make all the internal filters of the device support the F/S mode.

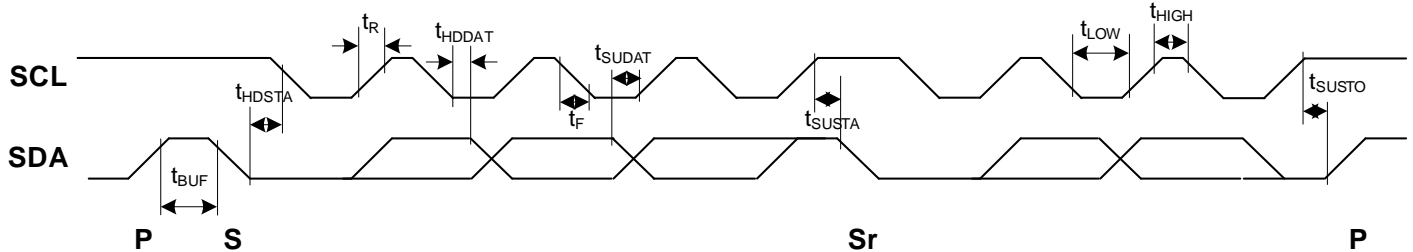

Figure 8. Bus Timing Diagram

Table 3. Bus Timing Diagram Definitions

Parameters	Symbol	Fast Mode		High-Speed Mode		Units
		MIN	MAX	MIN	MAX	
SCL operating frequency	f_{SCL}	0.001	0.4	0.001	3.4	MHz
Bus free time between stop and start conditions	t_{BUF}	600		160		ns
Hold time after repeated START condition. After this period, the first clock is generated.	t_{HDSTA}	100		100		ns
Repeated start condition setup time	t_{SUSTA}	100		100		ns
STOP condition setup time	t_{SUSTO}	100		100		ns
Data hold time	t_{HDDAT}	10	900	10	100	ns
Data setup time	t_{SUDAT}	100		20		ns
SCL clock low period	t_{LOW}	1300		200		ns
SCL clock high period	t_{HIGH}	600		60		ns
Data fall time	t_F		300		80	ns
Clock fall time	$t_{\bar{F}}$		300		40	ns
Clock rise time	t_R		300		40	ns
Clock/data rise time for $SCLK \leq 100kHz$	t_R		1000			ns

SMBus Alert Response

The SY24656 can respond to the SMBus Alert Response address, which provides a quick fault identification for simple slave devices. With an Alert arising, the Alert Response slave address (0001 100) will be broadcasted by the master and the Read/Write bit will be set high. After this Alert Response, the slave device, which generates an alert identifies itself by acknowledging the Alert Response, will send its address on the bus.

Like the I²C General Call, several different slave devices could be activated by the Alert Response at the same time. The bus arbitration rules will be applied is more than one slave tries to respond. The losing device will not produce an Acknowledge and keep the Alert line low until the interrupt is cleared.

The timing diagram for the SMBus Alert response operation is shown below.

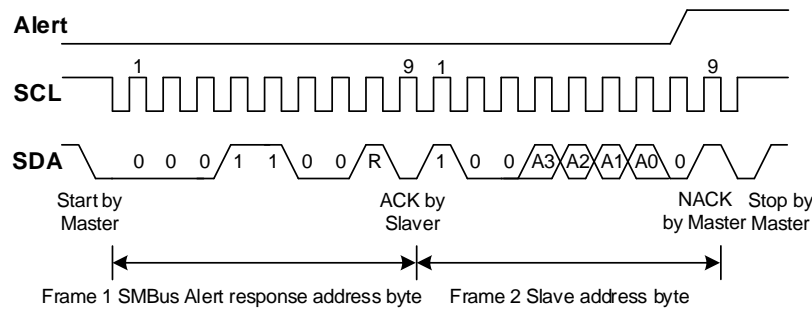

Figure 9. Timing Diagram for SMBus ALERT

Register Maps

SY24655 uses a bank of registers for holding configuration settings, status information and storing measurement and internal calculation results.

The following table summarizes the device registers. All 16-bit device registers can be accessed using two 8-bit bytes via the I²C interface.

Register Set Summary				
Register Address (Hex)	Register Name	Function	Power-On Reset (Hex)	Type
00h	Configuration Register	All-register reset, shunt voltage and bus voltage ADC conversion times, averaging and operating mode.	4127h	R/W
01h	Shunt Voltage Register	Shunt voltage measurement data.	0000h	R
02h	Bus Voltage Register	Bus voltage measurement data.	0000h	R
03h	Power Register	Power transmitted by load.	0000h	R
04h	Current Register	Contains the value of the calculated current flowing through the shunt resistor.	0000h	R
05h	Calibration Register	Sets full-scale range and LSB of current and power measurements. Overall system calibration.	0000h	R/W
06h	Mask/Enable Register	Alert configuration and Conversion Ready flag.	0000h	R/W
07h	Alert Limit Register	Contains the limit value to compare to the selected Alert function.	0000h	R/W
FEh	Manufacturer ID Register	Contains unique manufacturer identification number.	190Fh	R
FFh	Die ID Register	Contains unique die identification number.	0000h	R

Configuration Register (00h) (Read/Write)

The Configuration Register controls system reset and the operating modes for the device, the conversion time settings for the shunt and bus voltage measurements as well as the averaging mode used. The program of the operating mode that decides which signals are selected to be measured is also in the Configuration Register.

The Configuration Register can be read from at any time without changing the device configuration and conversion progress. Any one ongoing conversion will be stopped by writing to the Configuration until the write operation is finished, causing a new conversion beginning based on the new contents in the Configuration Register (00h). This break will avoid any uncertainty in the conditions used for the next completed conversion.

Configuration Register (00h) (Read/Write) Descriptions																					
Bit No.	Bit Name	Por Value	Description																		
D15	RST	0	Reset Bit Setting this bit to '1' resets all registers to default values; this bit self-clears.																		
D14		1																			
D13		0																			
D12		0																			
D11	AVG2	0	Averaging Mode Roles in the number of samples that are collected and averaged. The following table displays all the AVG bit settings and related number of averages for each bit setting. <table border="1" style="margin-left: 20px;"> <thead> <tr> <th>AVG[2:0]</th> <th>NUMBER OF AVERAGES</th> </tr> </thead> <tbody> <tr><td>000</td><td>1</td></tr> <tr><td>001</td><td>4</td></tr> <tr><td>010</td><td>16</td></tr> <tr><td>011</td><td>64</td></tr> <tr><td>100</td><td>128</td></tr> <tr><td>101</td><td>256</td></tr> <tr><td>110</td><td>512</td></tr> <tr><td>111</td><td>1024</td></tr> </tbody> </table>	AVG[2:0]	NUMBER OF AVERAGES	000	1	001	4	010	16	011	64	100	128	101	256	110	512	111	1024
AVG[2:0]	NUMBER OF AVERAGES																				
000	1																				
001	4																				
010	16																				
011	64																				
100	128																				
101	256																				
110	512																				
111	1024																				
D10	AVG1	0																			
D9	AVG0	0																			
D8	VBUSCT2	1	Bus Voltage Conversion Time Gives the conversion time for the bus voltage measurement. The following table displays the VBUSCT bit options and related conversion times for each bit setting. <table border="1" style="margin-left: 20px;"> <thead> <tr> <th>VBUSCT[2:0]</th> <th>CONVERSION TIME</th> </tr> </thead> <tbody> <tr><td>000</td><td>140us</td></tr> <tr><td>001</td><td>204us</td></tr> <tr><td>010</td><td>332us</td></tr> <tr><td>011</td><td>588us</td></tr> <tr><td>100</td><td>1.1ms</td></tr> <tr><td>101</td><td>2.116ms</td></tr> <tr><td>110</td><td>4.156ms</td></tr> <tr><td>111</td><td>8.244ms</td></tr> </tbody> </table>	VBUSCT[2:0]	CONVERSION TIME	000	140us	001	204us	010	332us	011	588us	100	1.1ms	101	2.116ms	110	4.156ms	111	8.244ms
VBUSCT[2:0]	CONVERSION TIME																				
000	140us																				
001	204us																				
010	332us																				
011	588us																				
100	1.1ms																				
101	2.116ms																				
110	4.156ms																				
111	8.244ms																				
D7	VBUSCT1	0																			
D6	VBUSCT0	0																			

D5	VSHCT2	1	Shunt Voltage Conversion Time Gives the conversion time for the shunt voltage measurement. The following table displays the VSHCT bit options and related conversion times for each bit setting.																		
D4	VSHCT1	0																			
D3	VSHCT0	0																			
				<table border="1"> <thead> <tr> <th>VSHCT[2:0]</th> <th>CONVERSION TIME</th> </tr> </thead> <tbody> <tr><td>000</td><td>140us</td></tr> <tr><td>001</td><td>204us</td></tr> <tr><td>010</td><td>332us</td></tr> <tr><td>011</td><td>588us</td></tr> <tr><td>100</td><td>1.1ms</td></tr> <tr><td>101</td><td>2.116ms</td></tr> <tr><td>110</td><td>4.156ms</td></tr> <tr><td>111</td><td>8.244ms</td></tr> </tbody> </table>	VSHCT[2:0]	CONVERSION TIME	000	140us	001	204us	010	332us	011	588us	100	1.1ms	101	2.116ms	110	4.156ms	111
VSHCT[2:0]	CONVERSION TIME																				
000	140us																				
001	204us																				
010	332us																				
011	588us																				
100	1.1ms																				
101	2.116ms																				
110	4.156ms																				
111	8.244ms																				
D2	MODE2	1	Operating Mode Selects continuous, triggered, or power-down mode of operation. These bits default to continuous shunt and bus measurement mode. The mode settings are shown as below.																		
D1	MODE1	1																			
D0	MODE0	1																			
				<table border="1"> <thead> <tr> <th>MODE[2:0]</th> <th>MODE</th> </tr> </thead> <tbody> <tr><td>000</td><td>Power-Down (or Shutdown)</td></tr> <tr><td>001</td><td>Shunt Voltage, Triggered</td></tr> <tr><td>010</td><td>Bus Voltage, Triggered</td></tr> <tr><td>011</td><td>Shunt and Bus, Triggered</td></tr> <tr><td>100</td><td>Power-Down (or Shutdown)</td></tr> <tr><td>101</td><td>Shunt Voltage, Continuous</td></tr> <tr><td>110</td><td>Bus Voltage, Continuous</td></tr> <tr><td>111</td><td>Shunt and Bus, Continuous</td></tr> </tbody> </table>	MODE[2:0]	MODE	000	Power-Down (or Shutdown)	001	Shunt Voltage, Triggered	010	Bus Voltage, Triggered	011	Shunt and Bus, Triggered	100	Power-Down (or Shutdown)	101	Shunt Voltage, Continuous	110	Bus Voltage, Continuous	111
MODE[2:0]	MODE																				
000	Power-Down (or Shutdown)																				
001	Shunt Voltage, Triggered																				
010	Bus Voltage, Triggered																				
011	Shunt and Bus, Triggered																				
100	Power-Down (or Shutdown)																				
101	Shunt Voltage, Continuous																				
110	Bus Voltage, Continuous																				
111	Shunt and Bus, Continuous																				

Shunt Voltage Register (01h) (Read-Only)

The Shunt Voltage Register stores voltage reading across the shunt resistor, V_{SHUNT} , which is represented in two's complement format. This register will display the averaged value on condition that it is set by the user.

Full-scale range = 81.9175mV (hexadecimal= 7FFF); LSB= 2.5µV.

Shunt Voltage Register (01h) (Read-Only) Description																
BIT NO.	D15	D14	D13	D12	D11	D10	D9	D8	D7	D6	D5	D4	D3	D2	D1	D0
BIT NAME	SIGN	SD14	SD13	SD12	SD11	SD10	SD9	SD8	SD7	SD6	SD5	SD4	SD3	SD2	SD1	SD0
POR VALUE	0	0	0	0	0	0	0	0	0	0	0	0	0	0	0	0

Bus Voltage Register (02h) (Read-Only)

The Bus Voltage Register is used to store the most recent bus voltage reading, V_{BUS} . Notes: this register displays the averaged value, when averaging is enabled.

Full-scale range = 40.96V (hexadecimal = 7FFF); LSB = 1.25mV.

Bus Voltage Register (02h) (Read-Only) Description																
BIT NO.	D15	D14	D13	D12	D11	D10	D9	D8	D7	D6	D5	D4	D3	D2	D1	D0
BIT NAME	-	BD14	BD13	BD12	BD11	BD10	BD9	BD8	BD7	BD6	BD5	BD4	BD3	BD2	BD1	BD0
POR VALUE	0	0	0	0	0	0	0	0	0	0	0	0	0	0	0	0

Power Register (03h) (Read-Only)

This register displays the averaged value, when averaging is enabled.

The value of the Power Register LSB is internally programmed 25 times than the programmed value of the Current_LSB.

The power in Watts recorded by the Power Register is equal to multiply the decimal values of the Bus Voltage Register with the decimal values of the Current Register, as shown in Equation (7).

Power Register (03h) (Read-Only) Description																
BIT NO.	D15	D14	D13	D12	D11	D10	D9	D8	D7	D6	D5	D4	D3	D2	D1	D0
BIT NAME	PD15	PD14	PD13	PD12	PD11	PD10	PD9	PD8	PD7	PD6	PD5	PD4	PD3	PD2	PD1	PD0
POR VALUE	0	0	0	0	0	0	0	0	0	0	0	0	0	0	0	0

Current Register (04h) (Read-Only)

If averaging is enabled, this register displays the averaged value. As shown in Equation (4), the value of the Current Register is equal to multiply the decimal value of the Calibration Register with the decimal value of the Shunt Voltage Register.

Current Register (04h) (Read-Only) Register Description																
BIT NO.	D15	D14	D13	D12	D11	D10	D9	D8	D7	D6	D5	D4	D3	D2	D1	D0
BIT NAME	CSIGN	CD 14	CD 13	CD 12	CD 11	CD 10	CD9	CD8	CD7	CD6	CD5	CD4	CD3	CD2	CD1	CD0
POR VALUE	0	0	0	0	0	0	0	0	0	0	0	0	0	0	0	0

Calibration Register (05h) (Read/Write)

This register has four main functions: (1) store the value of the shunt resistor which is used to produce the measured differential voltage; (2) set the resolution of the Current Register; (3) set the Current_LSB and the Power_LSB; (4) the overall system calibration.

Calibration Register (05h) (Read/Write) Description																
BIT NO.	D15	D14	D13	D12	D11	D10	D9	D8	D7	D6	D5	D4	D3	D2	D1	D0
BIT NAME	-	FS14	FS13	FS12	FS11	FS10	FS9	FS8	FS7	FS6	FS5	FS4	FS3	FS2	FS1	FS0
POR VALUE	0	0	0	0	0	0	0	0	0	0	0	0	0	0	0	0

Mask/Enable Register (06h) (Read/Write)

The Mask/Enable Register controls the Alert pin as well as how that pin functions. If multiple functions are enabled, the higher significant bit position Alert Function (D15-D11) takes the higher priority and responds to the Alert Limit Register.

Mask/Enable Register (06h) (Read/Write)			
BIT NO.	BIT NAME	POR VALUE	DESCRIPTION
D15	COL	0	Current Over-Voltage Setting this bit high configures the Alert pin to be asserted if the shunt voltage measurement following a conversion exceeds the value programmed in the Alert Limit Register.
D14	CUL	0	Current Under-Voltage Setting this bit high configures the Alert pin to be asserted if the shunt voltage measurement following a conversion drops below the value programmed in the Alert Limit Register.
D13	BOL	0	Bus Voltage Over-Voltage Setting this bit high configures the Alert pin to be asserted if the bus voltage measurement following a conversion exceeds the value programmed in the Alert Limit Register.
D12	BUL	0	Bus Voltage Under-Voltage Setting this bit high configures the Alert pin to be asserted if the bus voltage measurement following a conversion drops below the value programmed in the Alert Limit Register.
D11	POL	0	Power Over-Limit Setting this bit high configures the Alert pin to be asserted if the Power calculation made following a bus voltage measurement exceeds the value programmed in the Alert Limit Register.
D10	CNVR	0	Conversion Ready Setting this bit high configures the Alert pin to be asserted when the Conversion Ready Flag, Bit 3, is asserted indicating that the device is ready for the next conversion.
D9	-	0	
D8	-	0	
D7	-	0	
D6	-	0	
D5	-	0	
D4	AFF	0	Alert Function Flag While only one Alert Function can be monitored at the Alert pin at a time, the Conversion Ready can also be enabled to assert the Alert pin. Reading the Alert Function Flag following an alert allows the user to determine if the Alert Function was the source of the Alert. When the Alert Latch Enable bit is set to Latch mode, the Alert Function Flag bit clears only when the Mask/Enable Register is read. When the Alert Latch Enable bit is set to Transparent mode, the Alert Function Flag bit is cleared following the next conversion that does not result in an Alert condition.
D3	CVRF	0	Conversion Ready Flag Although the device can be read at any time, and the data from the last conversion is available, the Conversion Ready Flag bit is provided to help coordinate one-shot or triggered conversions. The Conversion Ready Flag bit is set after all conversions, averaging, and multiplications are complete. Conversion Ready Flag bit clears under the following conditions: 1.) Writing to the Configuration Register (except for Power-Down selection) 2.) Reading the Mask/Enable Register

D2	OVF	0	Math Overflow Flag This bit is set to '1' if an arithmetic operation resulted in an overflow error. It indicates that current and power data may be invalid.
D1	APOL	0	Alert Polarity bit; sets the Alert pin polarity. 1 = Inverted (active-high open collector) 0 = Normal (active-low open collector) (default)
D0	LEN	0	Alert Latch Enable Configures the latching feature of the Alert pin and Alert Flag bits. 1 = Latch enabled 0 = Transparent (default) When the Alert Latch Enable bit is set to Transparent mode, the Alert pin and Flag bit resets to the idle states when the fault has been cleared. When the Alert Latch Enable bit is set to Latch mode, the Alert pin and Alert Flag bit remains active following a fault until the Mask/Enable Register has been read.

Alert Limit Register (07h) (Read/Write)

The Alert Limit Register contains the limit value for the alert event selected in the Mask/Enable Register. If the corresponding register exceeds the limit value, an alarm occurs.

Alert Limit Register (07h) (Read/Write) Description																
BIT NO.	D15	D14	D13	D12	D11	D10	D9	D8	D7	D6	D5	D4	D3	D2	D1	D0
BIT NAME	AUL15	AUL14	AUL13	AUL12	AUL11	AUL10	AUL9	AUL8	AUL7	AUL6	AUL5	AUL4	AUL3	AUL2	AUL1	AUL0
POR VALUE	0	0	0	0	0	0	0	0	0	0	0	0	0	0	0	0

Manufacturer ID Register (FEh) (Read-Only)

The Manufacturer ID Register stores a unique identification number for the manufacturer.

Manufacturer ID Register (FEh) (Read-Only) Description																
BIT NO.	D15	D14	D13	D12	D11	D10	D9	D8	D7	D6	D5	D4	D3	D2	D1	D0
BIT NAME	ID15	ID14	ID13	ID12	ID11	ID10	ID9	ID8	ID7	ID6	ID5	ID4	ID3	ID2	ID1	ID0
POR VALUE	0	0	0	1	1	0	0	1	0	0	0	0	1	1	1	1

Die ID Register (FFh) (Read-Only)

The Die ID Register stores a unique identification number and the revision ID for the die.

Die ID Register (FFh) (Read-Only) Description																
BIT NO.	D15	D14	D13	D12	D11	D10	D9	D8	D7	D6	D5	D4	D3	D2	D1	D0
BIT NAME	DID11	DID10	DID9	DID8	DID7	DID6	DID5	DID4	DID3	DID2	DID1	DID0	RID3	RID2	RID1	RID0
POR VALUE	0	0	0	0	0	0	0	0	0	0	0	0	0	0	0	0

Application Schematic

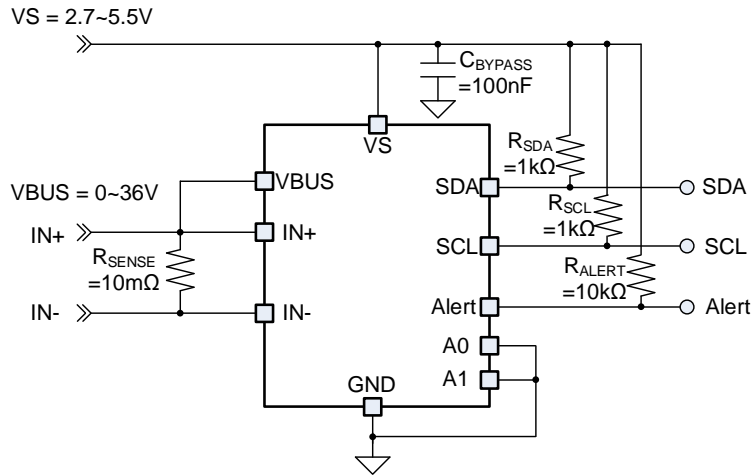

BOM List

Designator	Description	Part Number	MFR
C _{BYPASS}	100nF/50V/X7R, 0603	GCJ188R71H104KA12D	muRata
R _{SENSE}	10mΩ/1W, 1%, 2512	RL2512FK-070R01L	YAGEO
R _{SDA} , R _{SCL}	1kΩ, 1%, 0603		
R _{ALERT}	10kΩ, 1%, 0603		

Layout Guidelines

Using a Kelvin connection to connect the input pins to the current-sensing resistor R_{SENSE} . Due to the low resistance values of R_{SENSE} , poor PCB routing often leads to additional parasitic resistance between input pins, resulting in additional errors that cannot be ignored, this connection technique ensures that only R_{SENSE} impedance is detected between the input pins. Minimizing the loop formed by these connections.

Place the bypass capacitor (a 0.1μF MLCC is recommended) very near VCC and GND.

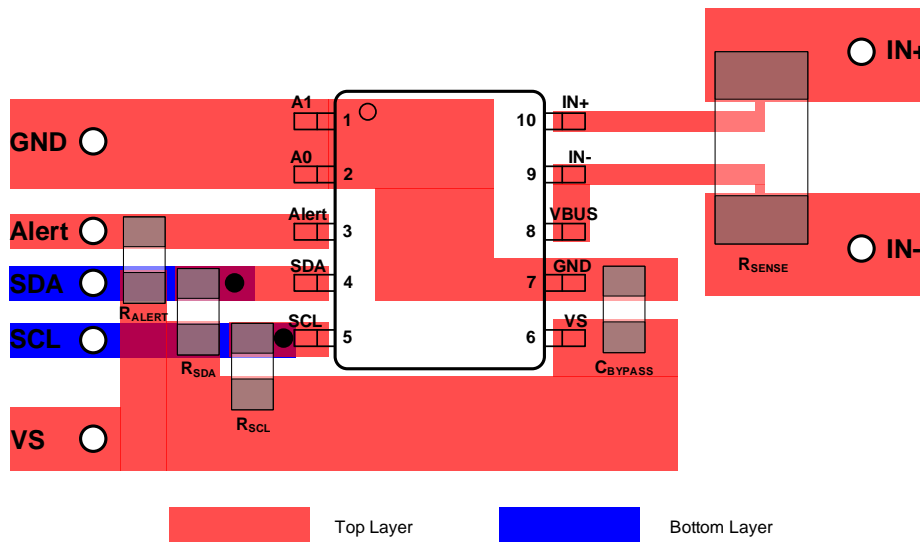
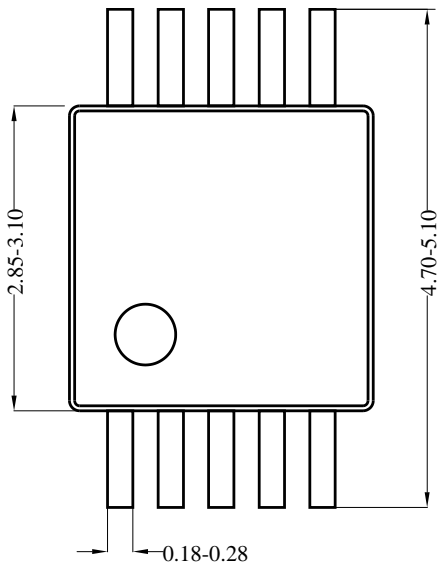
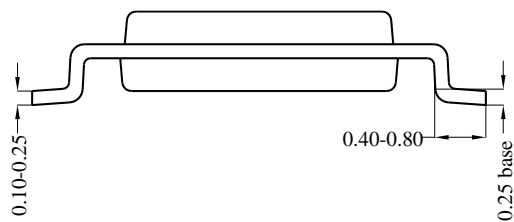

Figure 10. Recommended Layout

MSOP10 Package outline & PCB layout



Top view



Side view

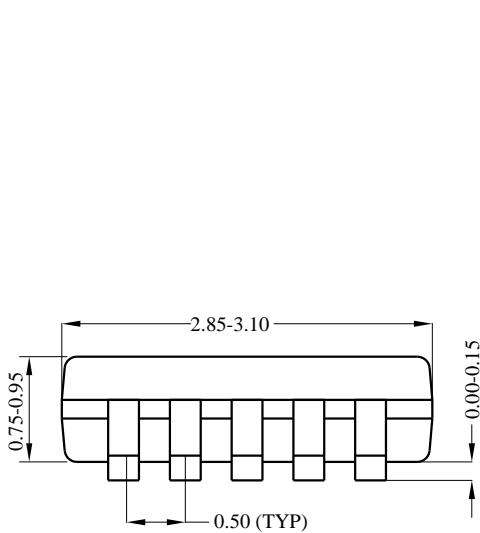

Front view

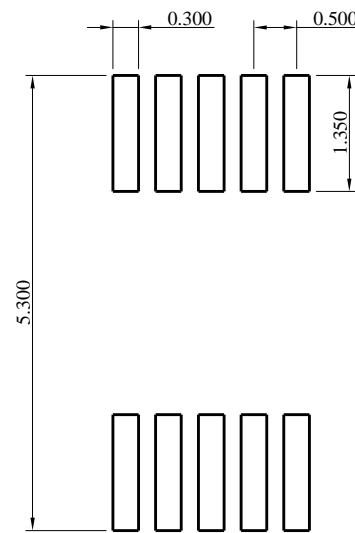

Recommended Pad Layout

Notes: All dimension in millimeter and exclude mold flash & metal burr.

Taping & Reel Specification

1. Taping Orientation

MSOP10

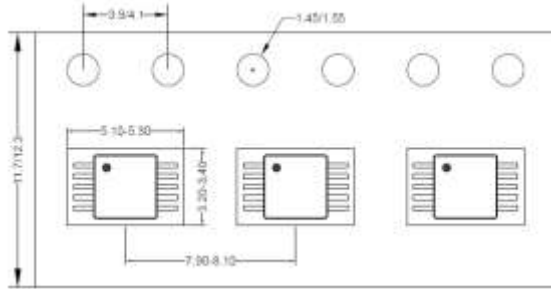

2. Carrier Tape & Reel Specification for Packages

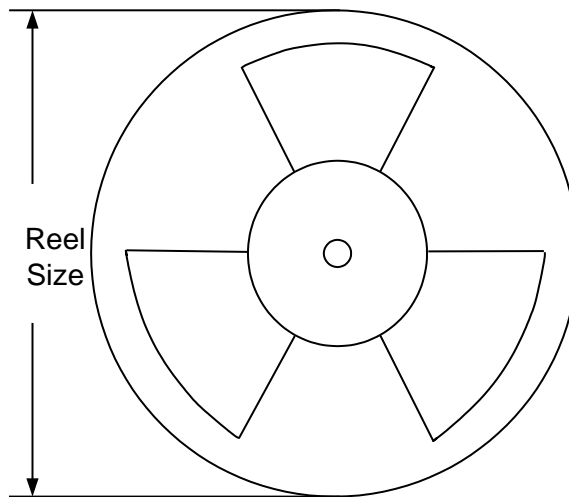

Package types	Tape width (mm)	Pocket pitch(mm)	Reel size (Inch)	Trailer length(mm)	Leader length (mm)	Qty per reel
MSOP10	12	8	13"	400	400	3000

3. Others: NA

Revision History

The revision history provided is for informational purpose only and is believed to be accurate, however, not warranted. Please make sure that you have the latest revision.

Date	Revision	Change
Aug. 27, 2021	Revision 0.9	Initial Release
Aug. 27, 2022	Revision 1.0	Production Release

IMPORTANT NOTICE

1. **Right to make changes.** Silergy and its subsidiaries (hereafter Silergy) reserve the right to change any information published in this document, including but not limited to circuitry, specification and/or product design, manufacturing or descriptions, at any time and without notice. This document supersedes and replaces all information supplied prior to the publication hereof. Buyers should obtain the latest relevant information before placing orders and should verify that such information is current and complete. All semiconductor products are sold subject to Silergy's standard terms and conditions of sale.
2. **Applications.** Application examples that are described herein for any of these products are for illustrative purposes only. Silergy makes no representation or warranty that such applications will be suitable for the specified use without further testing or modification. Buyers are responsible for the design and operation of their applications and products using Silergy products. Silergy or its subsidiaries assume no liability for any application assistance or designs of customer products. It is customer's sole responsibility to determine whether the Silergy product is suitable and fit for the customer's applications and products planned. To minimize the risks associated with customer's products and applications, customer should provide adequate design and operating safeguards. Customer represents and agrees that it has all the necessary expertise to create and implement safeguards which anticipate dangerous consequences of failures, monitor failures and their consequences, lessen the likelihood of failures that might cause harm and take appropriate remedial actions. Silergy assumes no liability related to any default, damage, costs or problem in the customer's applications or products, or the application or use by customer's third-party buyers. Customer will fully indemnify Silergy, its subsidiaries, and their representatives against any damages arising out of the use of any Silergy components in safety-critical applications. It is also buyers' sole responsibility to warrant and guarantee that any intellectual property rights of a third party are not infringed upon when integrating Silergy products into any application. Silergy assumes no responsibility for any said applications or for any use of any circuitry other than circuitry entirely embodied in a Silergy product.
3. **Limited warranty and liability.** Information furnished by Silergy in this document is believed to be accurate and reliable. However, Silergy makes no representation or warranty, expressed or implied, as to the accuracy or completeness of such information and shall have no liability for the consequences of use of such information. In no event shall Silergy be liable for any indirect, incidental, punitive, special or consequential damages, including but not limited to lost profits, lost savings, business interruption, costs related to the removal or replacement of any products or rework charges, whether or not such damages are based on tort or negligence, warranty, breach of contract or any other legal theory. Notwithstanding any damages that customer might incur for any reason whatsoever, Silergy's aggregate and cumulative liability towards customer for the products described herein shall be limited in accordance with the Standard Terms and Conditions of Sale of Silergy.
4. **Suitability for use.** Customer acknowledges and agrees that it is solely responsible for compliance with all legal, regulatory and safety-related requirements concerning its products, and any use of Silergy components in its applications, notwithstanding any applications-related information or support that may be provided by Silergy. Silergy products are not designed, authorized or warranted to be suitable for use in life support, life-critical or safety-critical systems or equipment, nor in applications where failure or malfunction of Silergy product can reasonably be expected to result in personal injury, death or severe property or environmental damage. Silergy assumes no liability for inclusion and/or use of Silergy products in such equipment or applications and therefore such inclusion and/or use is at the customer's own risk.
5. **Terms and conditions of commercial sale.** Silergy products are sold subject to the standard terms and conditions of commercial sale, as published at <http://www.silergy.com/stdterms>, unless otherwise agreed in a valid written individual agreement specifically agreed to in writing by an authorized officer of Silergy. In case an individual agreement is concluded only the terms and conditions of the respective agreement shall apply. Silergy hereby expressly objects to and denies the application of any customer's general terms and conditions with regard to the purchase of Silergy products by the customer.
6. **No offer to sell or license.** Nothing in this document may be interpreted or construed as an offer to sell products that is open for acceptance or the grant, conveyance or implication of any license under any copyrights, patents or other industrial or intellectual property rights. Silergy makes no representation or warranty that any license, either express or implied, is granted under any patent right, copyright, mask work right, or other intellectual property right. Information published by Silergy regarding third-party products or services does not constitute a license to use such products or services or a warranty or endorsement thereof. Use of such information may require a license from a third party under the patents or other intellectual property of the third party, or a license from Silergy under the patents or other intellectual property of Silergy.

For more information, please visit: www.silergy.com

© 2025 Silergy Corp.

All Rights Reserved.