



General Description

The SQ52911E is a high accuracy linear digital temperature sensor with an internal 12-bit ADC. This device has an accuracy of $\pm 0.5^{\circ}\text{C}$ with a resolution as low as 0.0625°C . The SQ52911E doesn't require any external component or external calibration. Only a simple formula is needed to calculate the temperature result directly. This device is a simple and high-precision alternative to thermistors, such as NTC/PTC.

The SQ52911E supports SMBus and I²C interfaces. It features SMBus alert function. Using a single pin, one of the four peripheral addresses can be selected. Up to four devices are allowed to be connected to the bus at the same time. The supply voltage of this device is 1.45V to 3.6V. The maximum quiescent current is 7.5 μA across the full supply voltage range. Its 1.6mm \times 1.6mm SOT563 package is 68% smaller than the SOT-23.

The SQ52911E can operate in a temperature range of -40°C to 125°C . It is an ideal temperature measuring device in communication, computer, consumer, environmental, industrial and instrumentation applications.

Features

- Accuracy without Calibration:
 - 0.5°C (max) from 0°C to 65°C
 - 1°C (max) from -40°C to 125°C
- Low Quiescent Current:
 - 7.5 μA Active (max)
 - 0.8 μA Shutdown (max)
- Supply Range: 1.45 to 3.6V
- Resolution: 12 Bits
- Digital Output: SMBus, and I²C Interface Compatibility
- SOT563 Package (1.6mm \times 1.6mm): 68% Smaller Footprint than SOT-23
- MSL Rating: MSL1

Applications

- Portable and Battery-powered Applications
- Power-supply Temperature Monitoring
- Computer Peripheral Thermal Protection
- Notebook Computers
- Battery Management
- Office Machines
- Thermostat Controls
- General Temperature Measurements:
 - Industrial Controls
 - Test Equipment
 - Medical Instrumentations

Function Block Diagram and Application Circuit

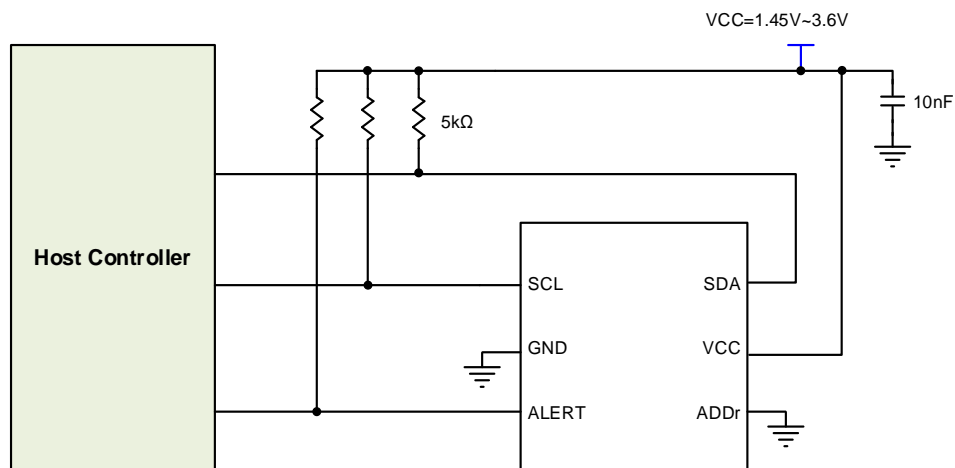

Figure 1. Simplified Application Circuit

Ordering Information

Ordering Part Number	Package Type	Top Mark
SQ52911EART	SOT563	AFxyz ^①

Note^①: x=year code, y=week code, z= lot number code.

Pinout (Top View)

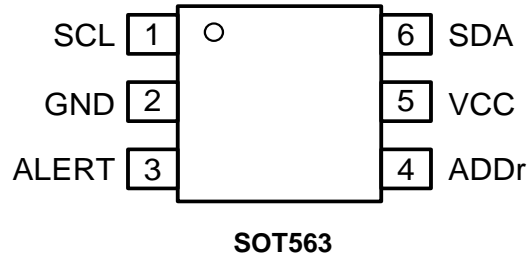

Pin Description

Pin No.	Pin Name	IO Type	Pin Description
1	SCL	I	Serial clock. Open-drain output; requires a pull-up resistor.
2	GND	/	Ground.
3	ALERT	O	Over temperature alert. Open-drain output; requires a pull-up resistor.
4	ADDR	I	Address select. Connects to GND or VCC.
5	VCC	P	Supply voltage, 1.45 V to 3.6 V.
6	SDA	I/O	Serial data. Open-drain output; requires a pull-up resistor.

Absolute Maximum Ratings

Parameter (Note 1)	Min	Max	Unit
VCC to GND		4	V
SCL, SDA, ADDR, ALERT	-0.5	4	
Junction Temperature, Operating		150	°C
Storage Temperature	-60	150	
ESD: HBM (Human Body Model)	± 4000		V
ESD: CDM (Charged Device Model)	± 2000		V

Thermal Information

Parameter (Note 2)	Value	Unit
θ_{JA} Junction-to-Ambient Thermal Resistance	265	°C/W
θ_{JC} Junction-to-Case (top) Thermal Resistance	38	
θ_{JB} Junction-to-Board Thermal Resistance	55	
ψ_{JT} Junction-to-Top Characterization Parameter	3	
ψ_{JB} Junction-to-Board Characterization Parameter	54	
P_D Power Dissipation $T_A = 25^\circ\text{C}$	0.47	W

Recommended Operating Conditions

Parameter (Note 3)	Min	Max	Unit
VCC to GND	1.45	3.6	V
Operating Free-air Temperature Range	-40	125	°C

Electrical Characteristics

At T_A = 25°C and VCC = 1.45 to 3.6V, unless otherwise noted (Note 4).

Parameter	Symbol	Test Conditions	Min	Typ	Max	Unit
Temperature Sense						
Temperature Sense Range			-40		125	°C
Accuracy (Temperature Error)		0°C to +65°C		±0.25	±0.5	°C
		-40°C to +125°C		±0.5	±1	°C
PSRR				0.2	0.5	°C/V
ADC Resolution				12		Bit
Resolution				0.0625		°C
ADC Conversion Time				26	35	ms
Conversion Modes		CR1 = 0, CR0 = 0		0.25		Conv/s
		CR1 = 0, CR0 = 1		1		
		CR1 = 1, CR0 = 0 (default)		4		
		CR1 = 1, CR0 = 1		8		
Power Supply						
Operating Supply Range	VCC		1.45		3.6	V
Average Quiescent Current	I _Q	Serial bus inactive, CR1 = 1, CR0 = 0 (default)		6.5	7.5	μA
		Serial bus active, SCL frequency = 400 kHz		22		
		Serial bus active, SCL frequency = 3.4 MHz		113		
Shutdown Current	I _{SD}	Serial bus inactive, CR1 = 1, CR0 = 0 (default)		0.5	0.8	μA
		Serial bus active, SCL frequency = 400 kHz		16		
		Serial bus active, SCL frequency = 3.4 MHz		109		
Digital Interface						
Input Capacitance				3		pF
Input Logic High, SDA, SCL	V _{IH}		0.7× VCC		3.6	V
Input Logic Low, SDA, SCL	V _{IL}		-0.5		0.3× VCC	V
Input Current, SDA, SCL, ALERT		0 < V _{IN} < 3.6 V			1	μA
Output Low Level Voltage, SDA, ALERT	V _{OL}	VCC > 2 V, I _{OL} = 3 mA	0		0.4	V
		VCC < 2 V, I _{OL} = 3 mA	0		0.2× VCC	
I ² C Timeout Time				30	40	ms

Timing Requirements

Parameter	Symbol	Test Conditions	Min	Typ	Max	Unit
I²C Interface- Fast Mode (Note 5)						
Clock Operation Frequency	f _{SCL}		0.001		0.4	MHz
START Condition Hold Time	t _{HD:STA}		600			ns
Low Period of The SCL Clock	t _{LOW}		1300			ns
High Period of The SCL Clock	t _{HIGH}		600			ns

SETUP Condition Hold Time	$t_{SU:STA}$		600			ns
DATA Hold Time (SDA Input)	$t_{HD:DAT}$		100		900	ns
DATA Setup Time (SDA Input)	$t_{SU:DAT}$		100			ns
Clock Rise Time	t_r	10%-90%			300	ns
Clock Fall Time	t_f	90%-10%			300	ns
Data Rise Time		10%-90%			300	ns
		10%-90%, SCLK \leq 100 kHz,			1000	ns
Data Fall Time		90%-10%			300	ns
Setup Time STOP Condition	$t_{SU:STO}$		600			ns
BUS Free Time Stop to Start	t_{BUF}		600			ns
I²C Interface- High-Speed Mode (Note 5)						
Clock Operation Frequency	f_{SCL}		0.001		3.4	MHz
START Condition Hold Time	$t_{HD:STA}$		160			ns
Low Period of the SCL Clock	t_{LOW}		210			ns
High Period of the SCL Clock	t_{HIGH}		60			ns
SETUP Condition Hold Time	$t_{SU:STA}$		160			ns
DATA Hold Time (SDA Input)	$t_{HD:DAT}$		25		105	ns
DATA Setup Time (SDA Input)	$t_{SU:DAT}$		25			ns
Clock Rise Time	t_r	10%-90%			40	ns
Clock Fall Time	t_f	90%-10%			40	ns
Data Fall Time		90%-10%			80	ns
Setup Time STOP Condition	$t_{SU:STO}$		160			ns
BUS Free Time Stop to Start	t_{BUF}		160			ns

Note 1: Stresses beyond the “Absolute Maximum Ratings” may cause permanent damage to the device. These are stress ratings only. Functional operation of the device at these or any other conditions beyond those indicated in the operational sections of the specification is not implied. Exposure to absolute maximum rating conditions for extended periods may affect device reliability.

Note 2: Package thermal resistance is measured in the natural convection and chip mounted on low effective single-layer Silergy Evaluation Board.

Note 3: The device is not guaranteed to function outside its operating conditions.

Note 4: Unless otherwise stated, limits are 100% production tested under pulsed load conditions such that $T_A \cong T_J = 25^\circ\text{C}$. Limits over the operating temperature range (see recommended operating conditions) and relevant voltage range(s) are guaranteed by design, test, or statistical correlation.

Note 5: Guaranteed by design or statistical correlation and not production tested.

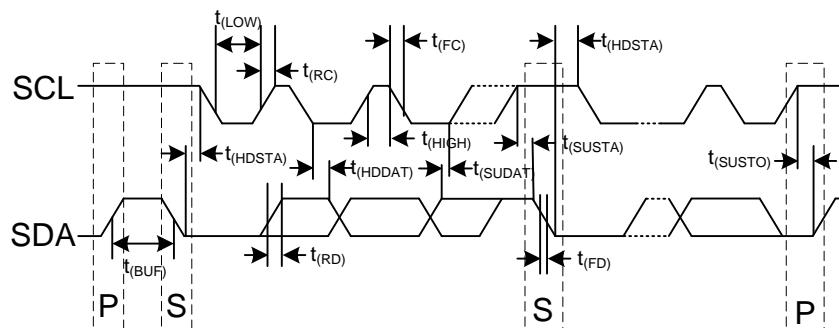

Figure 2. Two-Wire Timing Diagram

Function Description

Overview

The SQ52911E is a high accuracy digital temperature sensor which is compatible with SMBus and I²C interfaces. This device can operate in a temperature range of -40°C to 125°C. The following figure is the Functional Block Diagram.

The temperature sensor of the SQ52911E is inside the chip. The thermal path consists of the package leads and the plastic package. Due to the low thermal resistance of the metal, the package leads provide the main thermal path.

Functional Block Diagram

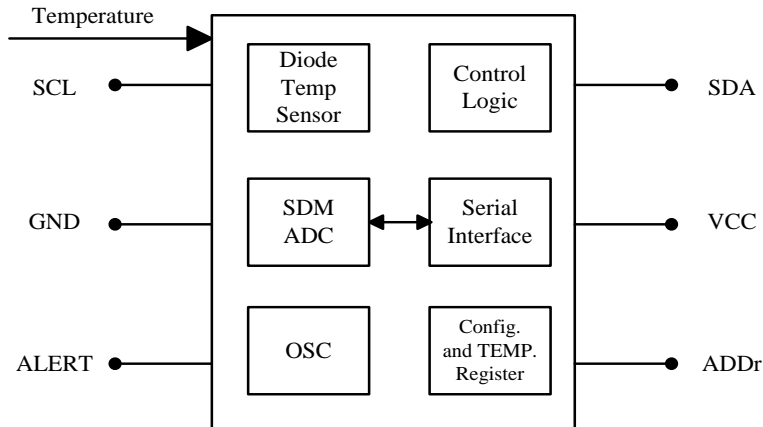

Feature Description

Digital Temperature Output

The digital outputs of each temperature measurement can be obtained in a 12-bit/13-bit, read-only register. When configuring the EM bit = 0 in the register, the result register will be 12 bits. When configuring the EM bit = 1 in the register, the result register will be 13bits. As shown in Table 7 and Table 8, Byte1 is the most significant byte (MSB) and Byte 2 is the least significant byte (LSB). The higher 12 bits (13 bits when EM=1) are valid data bits which are used to calculate the temperature result. The least significant byte doesn't have to be read if that information is not needed. The data format is shown in Table 1 and Table 2. One LSB equals 0.0625°C. Negative numbers are represented in binary two's complement format. When the SQ52911E is powered on or reset, the temperature register will read 0°C until the first conversion is completed. Bit D0 of Byte 2 can be used to distinguish between normal mode (EM bit=0) and extended mode (EM bit=1), with D0=1 representing extended mode and D0=0 representing normal mode. The unused bits in the temperature register will always be 0.

Table 1. 12-Bit Temperature Data Format

Temperature (°C)	Digital Output (Binary)	Hex
128	0111 1111 1111	7FF
127.9375	0111 1111 1111	7FF
100	0110 0100 0000	640
80	0101 0000 0000	500
75	0100 1011 0000	4B0
50	0011 0010 0000	320
25	0001 1001 0000	190
0.25	0000 0000 0100	004
0	0000 0000 0000	000
-0.25	1111 1111 1100	FFC
-25	1110 0111 0000	E70
-55	1100 1001 0000	C90

Table 1 lists some temperature values. When converting a temperature value to a digital data format, or vice versa, the following rules are followed.

To convert positive temperature value to a digital data format:

1. Divide the temperature by the resolution.
2. Convert the result to binary code with a 12-bit, left-justified, and MSB=0 format.

Example: $(80^{\circ}\text{C}) / (0.0625^{\circ}\text{C}/\text{LSB}) = 1280 = 500\text{h} = 0101\ 0000\ 0000$

To convert a positive digital data format to temperature value:

1. Convert the 12-bit, left-justified and MSB=0 to a decimal number.
2. Multiply this decimal data with the resolution.

Example: $0101\ 0000\ 0000 = 500\text{h} = 1280 \times (0.0625^{\circ}\text{C}/\text{LSB}) = 80^{\circ}\text{C}$

To convert negative temperature value to a digital data format:

1. Divide the absolute value of the temperature by the resolution.
2. Convert the result to binary code with a 12-bit, left-justified format.
3. Complement the binary number and add one.

Example: $(|-25^{\circ}\text{C}|) / (0.0625^{\circ}\text{C}/\text{LSB}) = 400 = 190\text{h} = 0001\ 1001\ 0000$

Two's complement format: $1110\ 0110\ 1111 + 1 = 1110\ 0111\ 0000$

To convert a negative digital data format to temperature value:

1. Complement the binary number and add one.
2. Convert it to a decimal number.
3. Multiply this decimal data with the resolution, then multiply by -1 for the negative sign.

Example: $1110\ 0111\ 0000$ has two's complement of $0001\ 1000\ 1111 + 1 = 0001\ 1001\ 0000$

$0001\ 1001\ 0000 = 190\text{h} = 400 \times (0.0625^{\circ}\text{C}/\text{LSB}) = 25^{\circ}\text{C}; 25^{\circ}\text{C} \times (-1) = -25^{\circ}\text{C}$

Table 2. 13-Bit Temperature Data Format

Temperature ($^{\circ}\text{C}$)	Digital Output (Binary)	Hex
150	0 1001 0110 0000	0960
128	0 1000 0000 0000	0800
127.9375	0 0111 1111 1111	07FF
100	0 0110 0100 0000	0640
80	0 0101 0000 0000	0500
75	0 0100 1011 0000	04B0
50	0 0011 0010 0000	0320
25	0 0001 1001 0000	0190
0.25	0 0000 0000 0100	0004
0	0 0000 0000 0000	0000
-0.25	1 1111 1111 1100	1FFC
-25	1 1110 0111 0000	1E70
-55	1 1100 1001 0000	1C90

Serial Interface

The SQ52911E is a peripheral device on the two-wire bus (I2C or SMBus). This device is connected to the bus using the open-drain I/O interface which integrates noise suppression filters and Schmitt triggers. The interface supports the transmission protocol for both fast mode (1kHz to 400kHz) and high-speed mode (1kHz to 3.4MHz). MSB will be transmitted first for all the data bytes.

Bus Overview

Devices connected to the I2C and SMBus are divided into controllers and peripherals. The transmission process always starts with the controller device initiating the transaction. The peripheral devices will accept the commands from the controller device. The controller device will control the bus access, generating the serial clock (SCL) and the START and STOP condition.

When the transmission starts, the controller device will send a START condition by pulling down the data-line (SDA) from a high to low logic level when the SCL is high. All the peripheral devices on the bus will shift in the address byte (the last bit indicates whether a read or write operation) on the rising edge of the SCL, and the corresponding peripheral device will pull down the SDA in the ninth clock cycle and generate an acknowledge to indicate the response to the controller device.

Then data will be sent over eight clock pluses followed by an acknowledge bit. When all data transfers have been finished, the controller device will send a STOP signal by pulling up the SDA pin when the SCL pin is high.

During the data transfer, the SDA line must remain stable when SCL is high. Otherwise, it will be identified as a START or STOP condition.

Serial Bus Address

To communicate with the SQ52911E, the controller device must send a corresponding peripheral device address. The peripheral device address byte consists of seven address bits and a R/W bit that indicates the intent of executing a read or write operation.

Four peripheral device addresses can be configured depending on the connection of the address pin. Table 3 describes the relationship between the address pin connection and the corresponding peripheral device addresses.

Table 3. Address Pin and Peripheral Device Addresses

Device Two-Wire Address	A0 Pin Connection
1001000	Ground
1001001	V+
1001010	SDA
1001011	SCL

Writing and Reading Operations

When writing or reading a particular register, the corresponding register address needs to be written in the pointer register. The value of the pointer register is written after the address byte. Every write operation to the SQ52911E requires a value for the pointer register (see Figure 4).

When reading from the SQ52911E, the pointer register address used is the one that was set during the last write operation. Therefore, a new register can only be read until a new value is written to the pointer register. This action is accomplished by issuing a peripheral address byte with the R/W bit low, followed by the pointer register byte. No additional data is required.

Next, the controller device issues a START condition and sends a peripheral address byte with the R/W bit high. See Figure 3 for details of this sequence.

Peripheral Mode Operations

The SQ52911E can operate as a peripheral receiver or transmitter. As a peripheral device, the SQ52911E never drives the SCL line.

1. Peripheral Receiver Mode

The controller device sends a peripheral address byte with the R/W bit low first, then the SQ52911E acknowledges reception of the corresponding peripheral address byte. The next byte is the pointer register's address. and SQ52911E acknowledges

reception of the pointer register byte. The next byte is data byte. The SQ52911E acknowledges reception of each data byte. The controller device can terminate data transfer by sending a START or STOP condition.

2. Peripheral Transmitter Mode

The controller device sends a peripheral address byte with the R/W bit high first. The SQ52911E acknowledges reception of the corresponding peripheral address byte. The next byte is the MSB returned from the peripheral device in the register specified by the pointer register. The controller acknowledges reception of the data byte. The next byte is the LSB returned from the peripheral device. The controller device acknowledges reception of the data byte and terminates data transfer by sending a Not-Acknowledge, START or STOP condition.

SMBus Alert Function

The SQ52911E supports the SMBus alert function. When the SQ52911E is in the Interrupt Mode (TM=1), if the controller device senses an ALERT condition on the ALERT line, it will send a SMBus alert command (0001 1001) to the bus. The peripheral device whose ALERT pin is active will acknowledge the command and return its peripheral address on the SDA line. The eighth bit of the return byte is determined by the ALERT condition. For POL = 0, the bit will be low if the temperature exceeds T_{HIGH}. This bit will be high if the temperature falls below T_{LOW}. The polarity of this bit will be inverted if POL = 1. See Figure 6 for more details.

If multiple devices on the bus respond to the SMBus alert command, the peripheral address they return will be arbitrated. The peripheral device that wins the arbitration will clear the ALERT status. The device with the lowest address will win the arbitration. The ALERT pin will be inactive if the SQ52911E wins the arbitration. If the SQ52911E loses the arbitration, its ALERT pin will remain active.

General Call

The SQ52911E responds to the general call address (000 0000) if the eighth bit is 0 and respond to the commands in the second byte. If the second byte is 0000 0110, the SQ52911E will reset the internal registers to the power-up values. The SQ52911E does not support the general address acquire command.

High-Speed (HS) Mode

When the communication frequency exceeds 400kHz, the controller device must issue a HS-Mode controller code (0000 1xxxx) after the START condition to switch the bus to a high-speed operation. The SQ52911E does not acknowledge this byte but will switch the filters on the SDA line and SCL line to operate in HS-mode with communication frequencies up to 3.4MHz. The controller device will issue a peripheral address byte after the HS Mode controller code to initiate a data transfer operation. If a STOP condition occurs on the bus, the bus will exit the HS Mode. The SQ52911E will switch the filters back to the fast-mode operation.

Timeout Function

If SCL is held low for 30ms (typical) between the START and STOP condition. The SQ52911E will reset the interface and will release the SDA line when the SCL pin is held low and will wait for a START condition. To avoid activating the time-out function, the communication frequency on the bus is at least 1kHz during normal communication.

Timing Diagrams

The SQ52911E is compatible with SMBus and I²C interfaces. Figures 3-6 list the different operations on the SQ52911E. Parameters for Figure 3 are defined in the Timing Requirements table. The bus states are explained below:

Acknowledge When a controller device issues the peripheral address, the receiving device will generate an acknowledge bit. The device that acknowledges must pull down the SDA line during the Acknowledge clock pulse and ensure that the SDA line is stable at a low level during the high period of the Acknowledge clock pulse. Setup and hold times must be taken into account. When the controller device receives data, it can issue a not-acknowledge on the last byte that has been sent by the peripheral device to terminate the data transfer.

Bus Idle Both SDA and SCL line are kept high.

Data Transfer The number of data bytes transferred is determined by the controller device. The SQ52911E can also be used for single byte updates. If only updating the MSB, the controller device can issue a START or STOP condition to terminate the data transfer.

Start Data Transfer When the SCL line is high, the SDA line will change from high to low, which will define a START condition. All data transfers begin with the START condition.

Stop Data Transfer When the SCL line is high, the SDA line will change from low to high, which will define a STOP condition. All data transfers end with a repeated START or STOP condition.

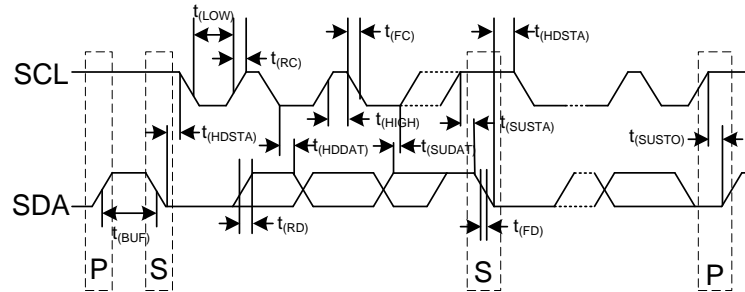
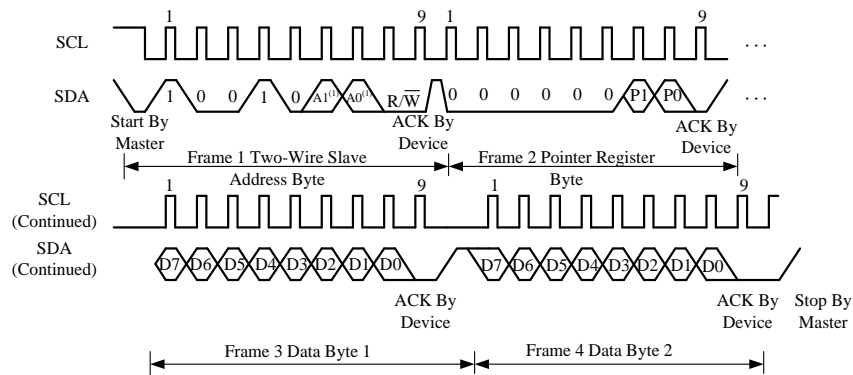
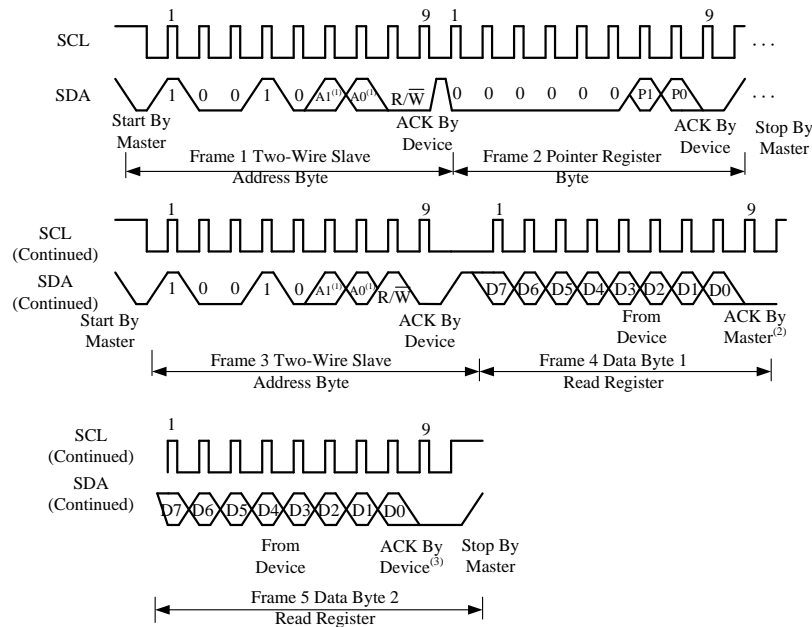

Figure 3. Two-Wire Timing Diagram



Note: (1) The value of A0 and A1 are determined by the ADDR pin.

Figure 4. Two-Wire Timing Diagram for Write Word Format



Note: (1) The value of A0 and A1 are determined by the ADDR pin.

(2) Controller device should leave SDA high to terminate a one-byte read operation.

(3) Controller device should leave SDA high to terminate a two-byte read operation

Figure 5. Two-Wire Timing Diagram for Read Word Format

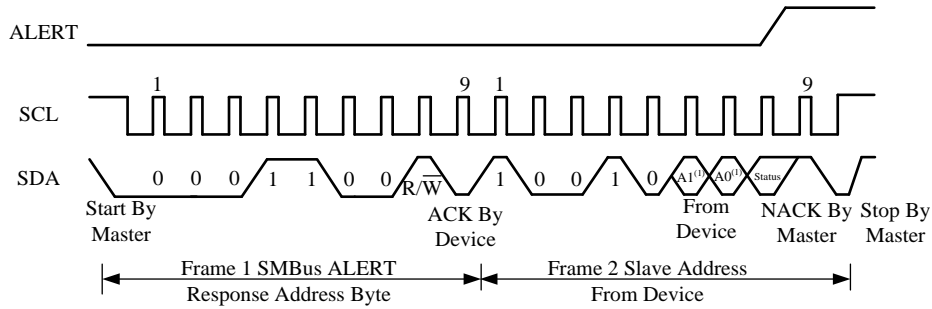

Note: (1) The values of A0 and A1 are determined by the ADDR pin

Figure 6. Timing Diagram for SMBus Alert

Device Functional Modes

Continuous-Conversion Mode

The default mode of the SQ52911E is the continuous conversion mode. In this mode, the ADC works continuously, stores the converted temperature value in the temperature register, and overwrites the last value. Configuring the conversion bits CR0/CR1 can change the conversion rate to 0.25Hz, 1Hz, 4Hz and 8Hz. The default conversion rate is 4Hz. The typical conversion time of the SQ52911E is 26ms. At different conversion rates, the SQ52911E will wait for the appropriate delay after a conversion is completed. Table 4 lists the settings for CR0/CR1.

Table 4. Conversion Rate Settings

CR1	CR0	CONVERSION RATE
0	0	0.25 Hz
0	1	1 Hz
1	0	4 Hz (default)
1	1	8 Hz

After power-up or general call reset, the SQ52911E will start a conversion after a short time, as shown in Figure 7. After 26ms (typical), the first data will be stored in the temperature register. The quiescent current during the conversion is 30μA (typical at +25°C). During the delay, the device is placed in a low power mode to reduce the quiescent current to 3.5μA (typical at +25°C).

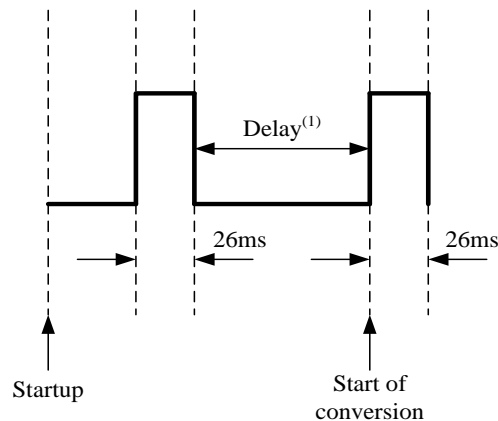

(1) Delay is set by CR1 and CR0.

Figure 7. Conversion Start

Extended Mode (EM)

The device is configured to normal mode when the Extended-Mode bit is 0. The device can be set to extended mode by setting the Extended-Mode bit to 1.

In normal mode, the Temperature, high limit, and the low limit registers are using 12-bit data format. In extended mode, these registers, are set to 13-bit data format. Temperature measurements above 128°C are allowed.

Shutdown Mode (SD)

When the shutdown mode bit is set 1, the device enters shutdown mode, which will shut down all the circuitry except the serial interface to save power. The current consumption in this mode is 0.5uA (typical). When the SD bit is set, the device will complete the current conversion and then enter SD mode. When the SD bit is cleared, the device starts operation in continuous conversion mode.

One-Shot / Conversion Ready (OS)

The SQ52911E has a one-shot temperature measurement mode. When the device is in shutdown mode, setting the OS bit high will start a single conversion. The OS bit will read 0 during the conversion, and 1 after the conversion is completed. The SQ52911E will return to the SD mode after the single conversion. When continuous temperature monitoring is not required, this function can reduce the power consumption.

When operating in OS mode, the SQ52911E can have a faster conversion rate because a single conversion takes only 26ms (typical). As a result, 30 or more conversions per second are possible.

Thermostat Mode (TM)

The thermostat mode bit indicates if the device operates in comparator mode (TM = 0) or interrupt mode (TM = 1).

1. Comparator Mode (TM = 0)

In comparator mode, the Alert pin is activated when the temperature equals or exceeds the value in the $T_{(HIGH)}$ register. The Alert pin resets when the temperature falls below the value in the $T_{(LOW)}$ register. See the High- and Low-Limit Register section for more details.

2. Interrupt Mode (TM = 1)

In interrupt mode, the Alert pin is activated when the temperature exceeds $T_{(HIGH)}$ or falls below $T_{(LOW)}$ register. The Alert pin resets when the controller device reads the register. See the High- and Low-Limit Register section for more details.

Programming

Pointer Register

Figure 8 shows the internal register structure of the SQ52911E. The pointer register is used for addressing an internal register. The lowest two bits of the pointer register are used for indicating a read or write operation. Table 5 shows the bits of the pointer register. P2 to P7 bits are always 0 during the write operation. Table 6 shows the pointer addresses of the available registers in the SQ52911E. The power-up value of P1 and P0 is 00. The temperature register can be read directly after power-on without writing the pointer register.

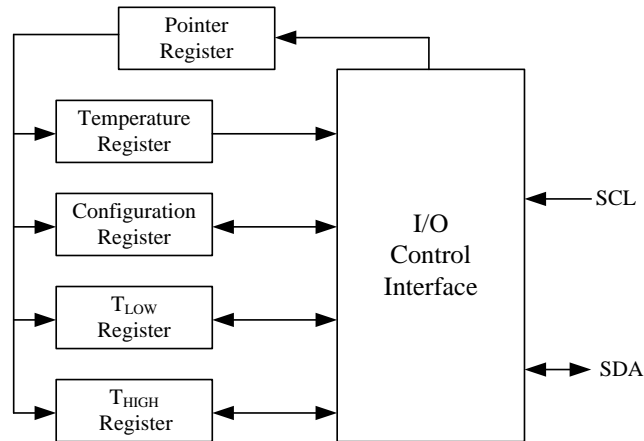

Figure 8. Internal Register Structure

Table 5. Point Register Byte

P7	P6	P5	P4	P3	P2	P1	P0
0	0	0	0	0	0	Register Bits	

Table 6. Point Addresses

P1	P0	REGISTER
0	0	Temperature Register (Read Only)
0	1	Configuration Register (Read/Write)
1	0	T _{LOW} Register (Read/Write)
1	1	T _{HIGH} Register (Read/Write)

Temperature Register

The Temperature register of the SQ52911E is a 12-bit (EM bit = 0) or a 13-bit (EM bit = 1), read only register. It stores the result of the most recent temperature conversion. As shown in Table 7 and Table 8, Byte1 is the most significant byte (MSB), and the Byte 2 is the least significant byte (LSB). The higher 12 bits (13 bits when EM=1) are valid data bits which are used for calculating the temperature result. The least significant byte doesn't have to be read if the information is not needed.

Table 7. Byte 1 of Temperature Register ⁽¹⁾

D7	D6	D5	D4	D3	D2	D1	D0
T11 (T12)	T10 (T11)	T9 (T10)	T8 (T9)	T7 (T8)	T6 (T7)	T5 (T6)	T4 (T5)

(1) Extended mode 13-bit configuration shown in parenthesis.

Table 8. Byte 2 of Temperature Register ⁽¹⁾

D7	D6	D5	D4	D3	D2	D1	D0
T3 (T4)	T2 (T3)	T1 (T2)	T0 (T1)	0 (T0)	0 (0)	0 (0)	0 (1)

(1) Extended mode 13-bit configuration shown in parenthesis.

Configuration Register

The Configuration register of the SQ52911E is a 16-bit read/write register, which stores the mode control bits. The power-up or reset value is shown in Table 9 and Table 10. All registers are updated byte by byte.

Table 9. Byte 1 of Configuration and Power-Up or Reset Format

D7	D6	D5	D4	D3	D2	D1	D0
OS	R1	R0	F1	F0	POL	TM	SD
0	1	1	0	0	0	0	0

Table 10. Byte 2 of Configuration and Power-Up or Reset Format

D7	D6	D5	D4	D3	D2	D1	D0
CR1	CR0	AL	EM	0	0	0	0
1	0	1	0	0	0	0	0

1. Shutdown Mode (SD)

When the Shutdown-mode bit is set, the device enters shutdown mode and will shut down all the circuitry except the serial interface to save power. The current consumption in this mode is 0.5uA (typical). When the SD bit is set, the device will complete the current conversion and then enter SD mode. When the SD bit is cleared, the device starts operation in continuous conversion mode.

2. Thermostat Mode (TM)

The thermostat-mode bit indicates whether the device operates in comparator mode (TM = 0) or interrupt mode (TM = 1). See the High- and Low-Limit Register section for more details.

3. Polarity (POL)

The polarity bit determines the polarity of the ALERT pin output. When the POL = 0 (default), the ALERT pin is active low. When POL = 1, the ALERT pin is active high and the state of the ALERT pin will be inverted. The operation of the ALERT pin is shown in Figure 9.

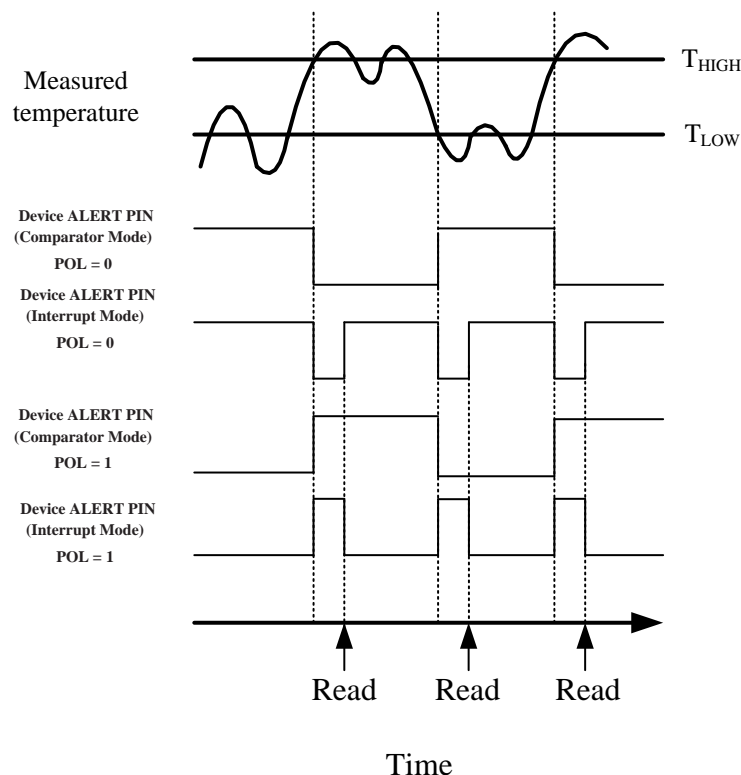

Figure 9. Output Transfer Function Diagrams

4. Fault Queue (F1/F0)

The SQ52911E will enter the fault condition when the measured temperature exceeds the value in the T_{LOW} and T_{HIGH} registers. Triggering the ALERT function requires consecutive fault conditions. The F1/F0 bits determine the number of the fault conditions required to activate the ALERT pin. The F1/F0 bits are provided to prevent a false alert due to the environmental noise. Table 11 shows the relationship between the settings of F1/F0 bits and the numbers of the fault condition. See the High- and Low-Limit Register section for the T_{HIGH} and T_{LOW} register byte order.

Table 11. SQ52911E Fault Settings

F1	F0	Consecutive Faults
0	0	1
0	1	2
1	0	4
1	1	6

5. Converter Resolution (R1/R0)

The R1/R0 bits are read-only bits. The SQ52911E will set the R1/R0 to 11 after power-up, which will set the Temperature register to a 12-bit resolution.

6. One-Shot (OS)

The SQ52911E has a one-shot temperature measurement mode. When the device is in shutdown mode, setting the OS bit high will start a single conversion. The OS bit will read 0 during the conversion, and 1 after the conversion is completed. The SQ52911E will return to the SD mode after the single conversion.

See the One-Shot/Conversion Ready (OS) section for more details.

7. Extension Mode (EM) Bit

The device is configured to normal mode when the Extended-Mode bit is 0. The device can be set to extended mode by setting the Extended-Mode bit to 1. In normal mode, the Temperature, high limit, and the low limit registers are using 12-bit data format. See the Extended Mode (EM) section for more details.

8. Alert (AL) Bit

The AL bit is a read-only bit. Reading the AL bit provides information about the comparator mode status. If $POL = 0$, the AL bit will read 0 when the temperature equals or exceeds the $T_{(HIGH)}$ value for the expected number of consecutive faults. The AL bit will remain at 0 until the temperature drops below the $T_{(LOW)}$ temperature for the expected number of consecutive faults. When the POL bit is reversed, the AL bit will also be reversed. The status of the TM bit does not affect the status of the AL bit.

9. Conversion Rate (CR)

The CR1/CR0 bits configure the device conversion rate. Four optional conversion rates are available: 0.25Hz, 1Hz, 4Hz (default), 8Hz. Table 4 shows more information of conversion rate bits.

High- and Low-Limit Registers

The temperature limit data is stored in the T_{LOW} and T_{HIGH} registers and compared to the temperature value after each temperature conversion. The result of the comparison determines the ALERT pin's status. The state of ALERT pin also depends on whether the SQ52911E is in comparator mode (TM bit = 0) or interrupt mode (TM bit = 1).

In comparator mode, the ALERT pin becomes active when the temperature equals or exceeds the $T_{(HIGH)}$ for the expected number of consecutive faults. The ALERT pin will remain active until the temperature drops below the $T_{(LOW)}$ for the expected number of consecutive faults.

In interrupt mode, the ALERT pin becomes active when the temperature equals or exceeds the $T_{(HIGH)}$ for the expected number of consecutive faults. The ALERT pin will remain active until a read operation of any register occurs, or a successful response to the SMBus alert command, or the device enters shutdown mode. When the ALERT pin is cleared, it will become active only when the temperature drops below the $T_{(LOW)}$ for the expected number of consecutive faults. It will remain active until a read operation of any register, or a successful response to the SMBus alert command, or the SQ52911E enters shutdown mode.

The ALERT pin can also be cleared by resetting the device using the General Call Reset command.

Figure 9 illustrates the behavior of ALERT pin in different modes. Tables 12-15 show the format of $T_{(HIGH)}$ and $T_{(LOW)}$. The power-up default values for $T_{(HIGH)}$ and $T_{(LOW)}$ are: $T_{(HIGH)} = +80^{\circ}\text{C}$, $T_{(LOW)} = +75^{\circ}\text{C}$.

Table 12. Byte 1 Temperature Register $_{HIGH}^{(1)}$

D7	D6	D5	D4	D3	D2	D1	D0
H11 (H12)	H10 (H11)	H9 (H10)	H8 (H9)	H7 (H8)	H6 (H7)	H5 (H6)	H4 (H5)

(1) Extended mode 13-bit configuration shown in parenthesis.

Table 13. Byte 2 Temperature Register $_{HIGH}$

D7	D6	D5	D4	D3	D2	D1	D0
H3 (H4)	H2 (H3)	H1 (H2)	H0 (H1)	0 (H0)	0 (0)	0 (0)	0 (0)

Table 14. Byte 1 Temperature Register $_{LOW}^{(1)}$

D7	D6	D5	D4	D3	D2	D1	D0
L11 (L12)	L10 (L11)	L9 (L10)	L8 (L9)	L7 (L8)	L6 (L7)	L5 (L6)	L4 (L5)

(1) Extended mode 13-bit configuration shown in parenthesis.

Table 15. Byte 2 Temperature Register $_{LOW}$

D7	D6	D5	D4	D3	D2	D1	D0
L3 (L4)	L2 (L3)	L1 (L2)	L0 (L1)	0 (L0)	0 (0)	0 (0)	0 (0)

Application Schematic

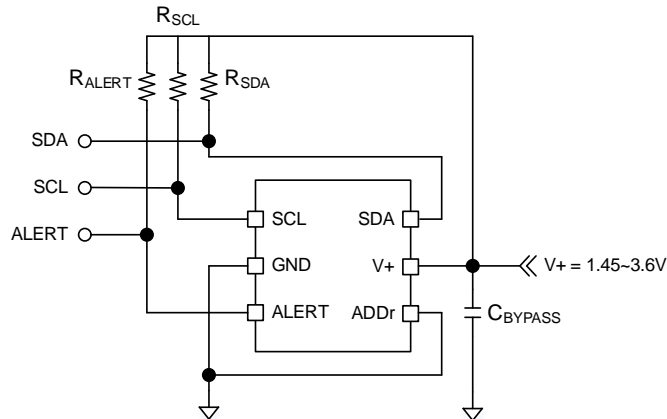

BOM List

Designator	Description	Part Number	MFR
C1	100nF/50V, 0603		
R1, R2, R3	2kΩ, 0603, 1%		

Layout Guidelines

Place the power-supply bypass capacitor as close as possible to the supply and ground pins. The recommended value of this bypass capacitor is 100nF. Additional decoupling capacitance can be added to compensate for noisy or high-impedance power supplies. Pull up the open-drain output pins (SDA, SCL and ALERT) through 2kΩ pull-up resistors.

Ensure good thermal contact between the area where the temperature is measured and the device package, by using a thick trace under the package body, connected to the GND pin.

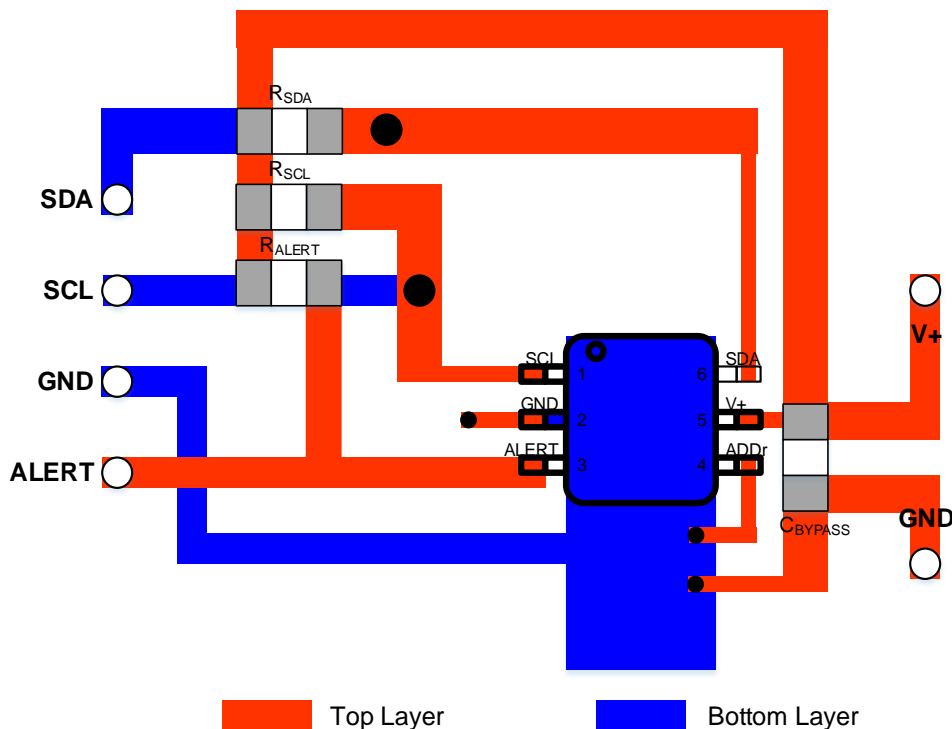

SOT563 Package Outline Drawing

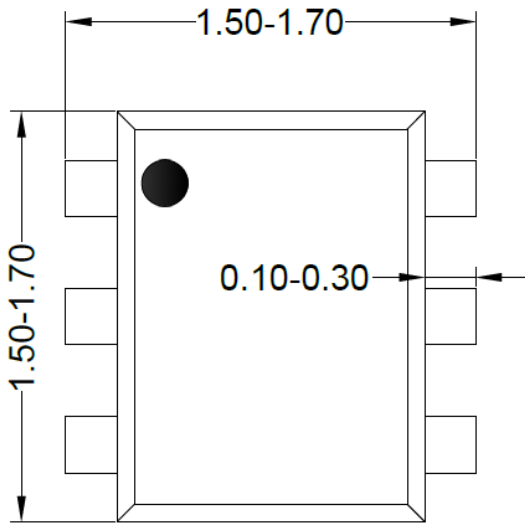

Top view

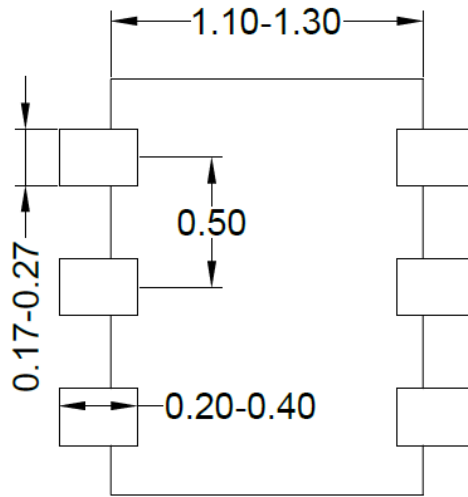

Bottom view

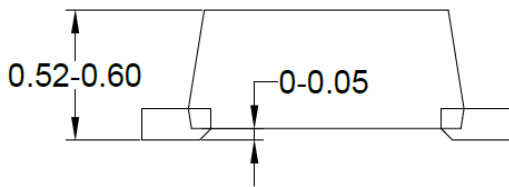

Side View

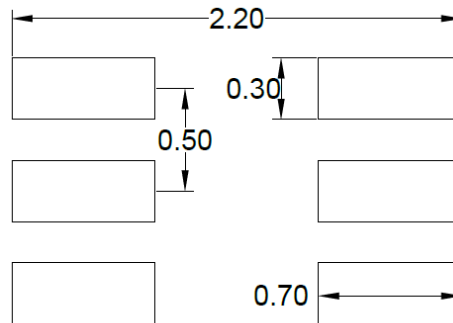

**Recommended PCB layout
(Reference only)**

Note: All dimensions in millimeters and exclude mold flash & metal burr.

Tape and Reel Information

Tape Dimensions and Pin 1 Orientation

SOT563

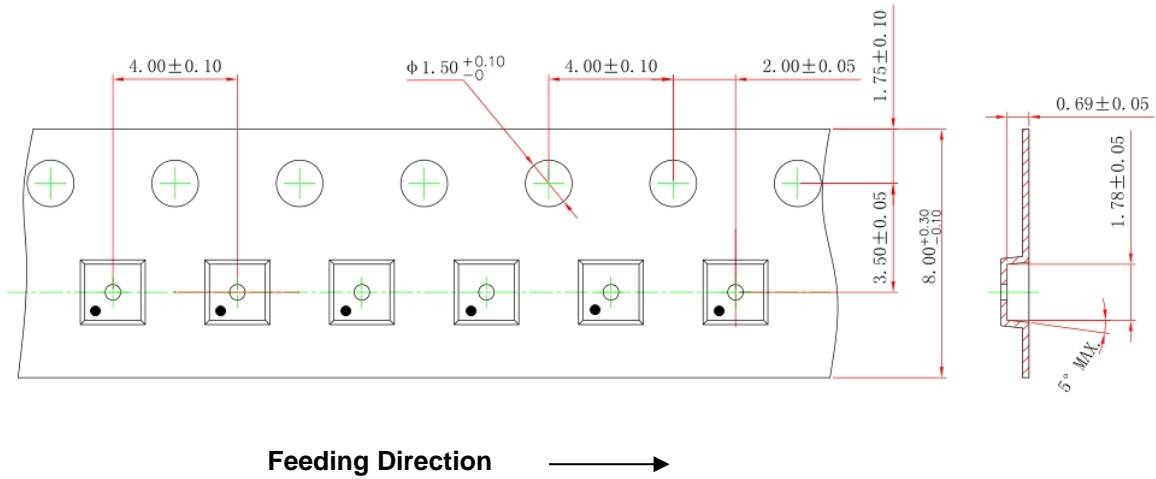

Reel Dimensions

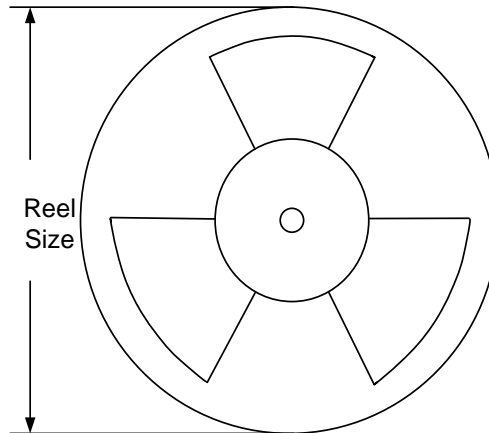

Package types	Tape width (mm)	Pocket pitch(mm)	Reel size (Inch)	Trailer * length(mm)	Leader * length (mm)	Qty per reel (pcs)
SOT563	8	4	7"	280	160	5000



Revision History

The revision history provided is for informational purpose only and is believed to be accurate, however, not warranted. Please make sure that you have the latest revision.

Date	Revision	Change
Mar. 31, 2025	Revision 1.0	Initial Release

IMPORTANT NOTICE

1. **Right to make changes.** Silergy and its subsidiaries (hereafter Silergy) reserve the right to change any information published in this document, including but not limited to circuitry, specification and/or product design, manufacturing or descriptions, at any time and without notice. This document supersedes and replaces all information supplied prior to the publication hereof. Buyers should obtain the latest relevant information before placing orders and should verify that such information is current and complete. All semiconductor products are sold subject to Silergy's standard terms and conditions of sale.
2. **Applications.** Application examples that are described herein for any of these products are for illustrative purposes only. Silergy makes no representation or warranty that such applications will be suitable for the specified use without further testing or modification. Buyers are responsible for the design and operation of their applications and products using Silergy products. Silergy or its subsidiaries assume no liability for any application assistance or designs of customer products. It is customer's sole responsibility to determine whether the Silergy product is suitable and fit for the customer's applications and products planned. To minimize the risks associated with customer's products and applications, customer should provide adequate design and operating safeguards. Customer represents and agrees that it has all the necessary expertise to create and implement safeguards which anticipate dangerous consequences of failures, monitor failures and their consequences, lessen the likelihood of failures that might cause harm and take appropriate remedial actions. Silergy assumes no liability related to any default, damage, costs or problem in the customer's applications or products, or the application or use by customer's third-party buyers. Customer will fully indemnify Silergy, its subsidiaries, and their representatives against any damages arising out of the use of any Silergy components in safety-critical applications. It is also buyers' sole responsibility to warrant and guarantee that any intellectual property rights of a third party are not infringed upon when integrating Silergy products into any application. Silergy assumes no responsibility for any said applications or for any use of any circuitry other than circuitry entirely embodied in a Silergy product.
3. **Limited warranty and liability.** Information furnished by Silergy in this document is believed to be accurate and reliable. However, Silergy makes no representation or warranty, expressed or implied, as to the accuracy or completeness of such information and shall have no liability for the consequences of use of such information. In no event shall Silergy be liable for any indirect, incidental, punitive, special or consequential damages, including but not limited to lost profits, lost savings, business interruption, costs related to the removal or replacement of any products or rework charges, whether or not such damages are based on tort or negligence, warranty, breach of contract or any other legal theory. Notwithstanding any damages that customer might incur for any reason whatsoever, Silergy' aggregate and cumulative liability towards customer for the products described herein shall be limited in accordance with the Standard Terms and Conditions of Sale of Silergy.
4. **Suitability for use.** Customer acknowledges and agrees that it is solely responsible for compliance with all legal, regulatory and safety-related requirements concerning its products, and any use of Silergy components in its applications, notwithstanding any applications-related information or support that may be provided by Silergy. Silergy products are not designed, authorized or warranted to be suitable for use in life support, life-critical or safety-critical systems or equipment, nor in applications where failure or malfunction of a Silergy product can reasonably be expected to result in personal injury, death or severe property or environmental damage. Silergy assumes no liability for inclusion and/or use of Silergy products in such equipment or applications and therefore such inclusion and/or use is at the customer's own risk.
5. **Terms and conditions of commercial sale.** Silergy products are sold subject to the standard terms and conditions of commercial sale, as published at <http://www.silergy.com/stdterms>, unless otherwise agreed in a valid written individual agreement specifically agreed to in writing by an authorized officer of Silergy. In case an individual agreement is concluded only the terms and conditions of the respective agreement shall apply. Silergy hereby expressly objects to and denies the application of any customer's general terms and conditions with regard to the purchase of Silergy products by the customer.
6. **No offer to sell or license.** Nothing in this document may be interpreted or construed as an offer to sell products that is open for acceptance or the grant, conveyance or implication of any license under any copyrights, patents or other industrial or intellectual property rights. Silergy makes no representation or warranty that any license, either express or implied, is granted under any patent right, copyright, mask work right, or other intellectual property right. Information published by Silergy regarding third-party products or services does not constitute a license to use such products or services or a warranty or endorsement thereof. Use of such information may require a license from a third party under the patents or other intellectual property of the third party, or a license from Silergy under the patents or other intellectual property of Silergy.

For more information, please visit: www.silergy.com

© 2025 Silergy Corp.

All Rights Reserved.