

### General Description

The SY205237DVD is an ultra-low capacitance transient voltage suppressor (TVS) designed to provide electrostatic discharge (ESD) protection for high-speed data interfaces.

With a typical capacitance of 0.35pF, the SY205237DVD is designed to protect parasitic-sensitive systems against overvoltage and overcurrent transient events. It complies with IEC 61000-4-2 (ESD), ( $\pm 15\text{kV}$  air,  $\pm 15\text{kV}$  contact discharge), and IEC 61000-4-5 (Surge) (7A, 8/20 $\mu\text{s}$ ) standards.

Each SY205237DVD device can protect four high-speed data lines. Its ultra-low capacitance, ultra-small size, and high ESD robustness make the SY205237DVD ideal for high-speed data ports and high-frequency line applications. The low clamping voltage of the SY205237DVD guarantees minimum stress on the protected device.

The SY205237DVD is available in a compact DFN2.5x1.0-10 package.

### Features

- Operating Voltage: 3.3V and Below
- Transient Protection for High-Speed Data Lines
  - IEC61000-4-2 (ESD)  $\pm 15\text{kV}$  (Air)  $\pm 15\text{kV}$  (Contact)
  - IEC61000-4-5 (Surge) 7A (8/20 $\mu\text{s}$ )
- Protects Four High-Speed Data Lines
- Ultra Low Capacitance: 0.35pF (Typical)
- Low Clamping Voltage

### Applications

- USB2.0&3.x, USB Type-C
- HDMI 1.3, 1.4, 2.0 and 2.1
- V-By-One
- Display Ports
- 10G Ethernet Ports
- TV and Set-Top Boxes
- PCI Express and SATA Ports

### Mechanical Characteristics

- DFN2.5x1.0-10 Package
- Marking: Device Code, Date Code
- Packaging: Tape and Reel

### Circuit Diagram

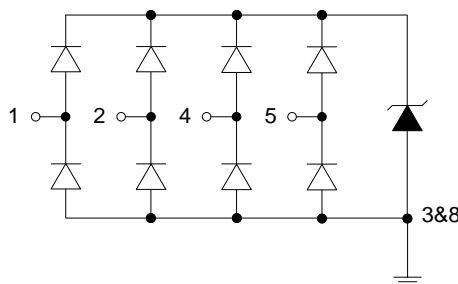

## Ordering Information

## Pinout (Top View)

Part Number	Package Type	Top Mark
SY205237DVD	DFN2.5x1.0-10	a4YWA

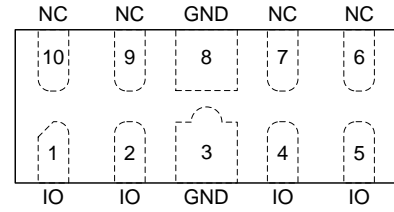

## Marking Codes

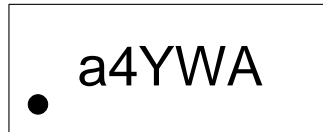

Notes: “a4” is the device code, fixed.

“YWA” is the date code.

## Pin Descriptions

Device Pins	Name	Description
1	Input/Output	IO1
2	Input/Output	IO2
3	Ground	GND
4	Input/Output	IO3
5	Input/Output	IO4

Absolute Maximum Ratings(Note 1)				
Parameter	Symbol	Min	Max	Unit
Peak Pulse Current (8/20μs)	$I_{PP}$		7	A
ESD per IEC 61000-4-2 (Air)	$V_{ESD}$	-15	15	kV
ESD per IEC 61000-4-2 (Contact)		-15	15	
Junction Temperature	$T_J$	-40	+125	°C
Storage Temperature	$T_{STG}$	-55	+150	°C

Electrical Characteristics (IO Referenced to GND, $T_A = 25^\circ\text{C}$ , Note 4)						
Parameter	Symbol	Test Condition	Min	Typ	Max	Unit
Nominal Reverse Working Voltage	$V_{RWM}$				3.3	V
Reverse Leakage Current at $V_{RWM}$	$I_R$	$V_{RWM} = 3.3\text{V}, T_A = 25^\circ\text{C}$		0.01	0.1	μA
Reverse Triggering Voltage at $I_{R1}$	$V_{th}$	$I_{th} = 1\text{mA}$	5.0		9	V
Clamping Voltage at $I_{PP}$ (Note 5)	$V_C$	$I_{PP} = 16\text{A}, t_p = 10/100\text{ns}$		9.5		V
Clamping Voltage at $I_{PP}$ (Note 5)	$V_C$	$I_{PP} = 7\text{A}, t_p = 8/20\mu\text{s}$		9.5	11	V
Dynamic Resistance (Notes 2, 5)	$R_{DYN}$	$t_p = 10/100\text{ns}$		0.24		Ω
Parasitic Capacitance (Note 5)	$C_{ESD}$	$V_R = 1.65\text{V}, f = 1\text{MHz}, \text{IO-GND}$		0.35	0.5	pF

**Note 1:** Stresses beyond the “Absolute Maximum Ratings” may cause permanent damage to the device. These are stress ratings only. Functional operation of the device at these or any other conditions beyond those indicated in the

operational sections of the specification is not implied. Exposure to absolute maximum rating conditions for extended periods may affect device reliability.

**Note 2:**  $R_{DYN}$  calculated based on  $I_{PP}=8A$  to  $I_{PP}=16A$ ,  $t_p = 10/100ns$ .

**Note 3:** The device is not guaranteed to function outside its operating conditions.

**Note 4:** Unless otherwise stated, limits are 100% production tested under pulsed load conditions such that  $T_A \cong T_J = 25^\circ C$ . Limits over the operating temperature range (see recommended operating conditions) and relevant voltage range(s) are guaranteed by design, test, or statistical correlation.

**Note 5:** Guaranteed by design or statistical correlation and not production tested.

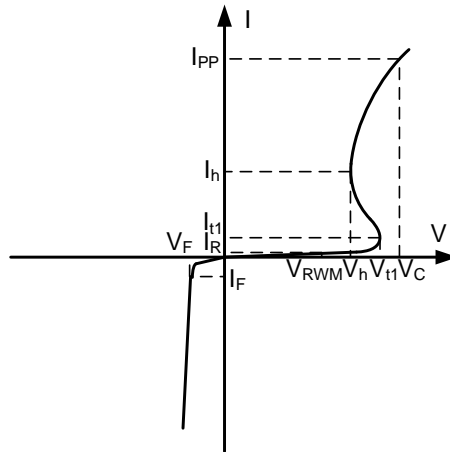
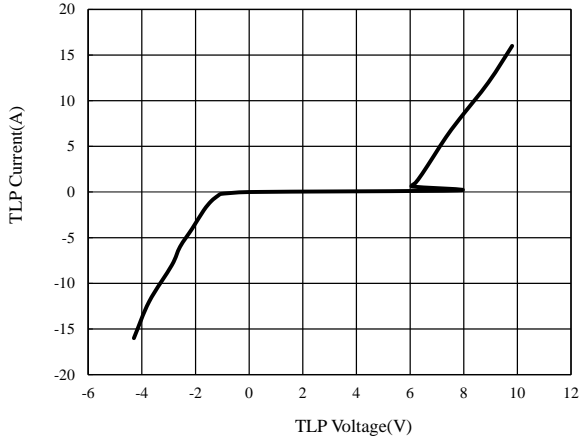

Figure 1. Uni-Directional TVS

## Typical Performance Characteristics, IO Referenced to GND

### TLP Testing



### Clamping Voltage vs. Peak Pulse Current (8/20μs)

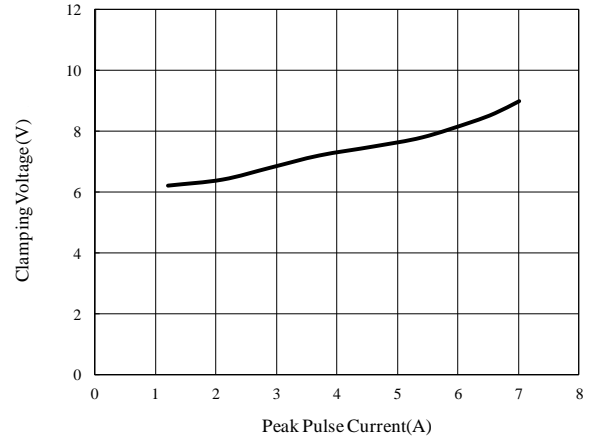

### Capacitance vs. Voltage

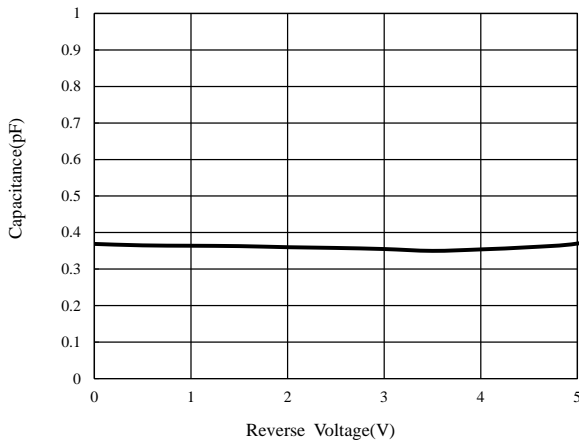

### Insertion Loss S21

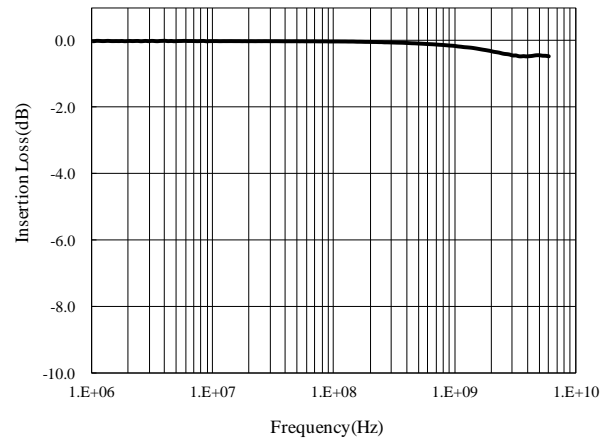

### ESD Clamping (+8kV Contact per IEC 61000-4-2)

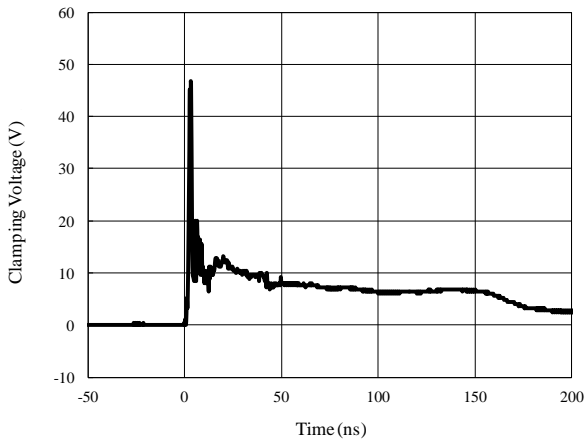

### ESD Clamping (-8kV Contact per IEC 61000-4-2)

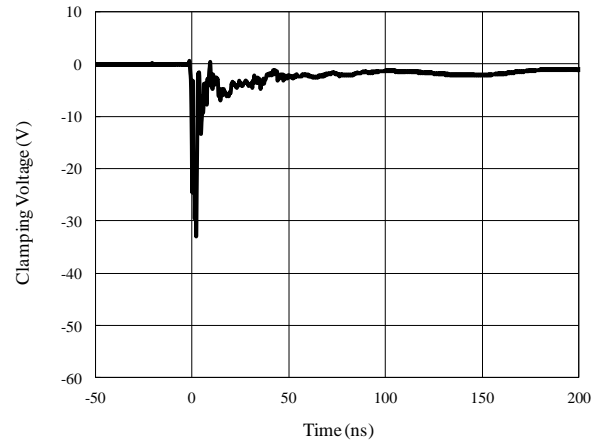

### Eye Diagram Measurement for HDMI2.1

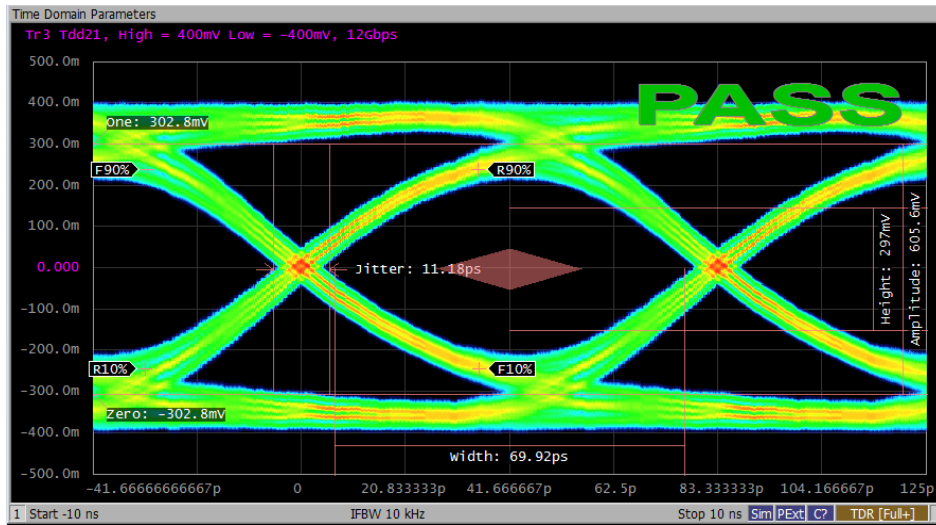

Data rate 12Gb/s

HDMI2.1 Eye Diagram without SY205237DVD

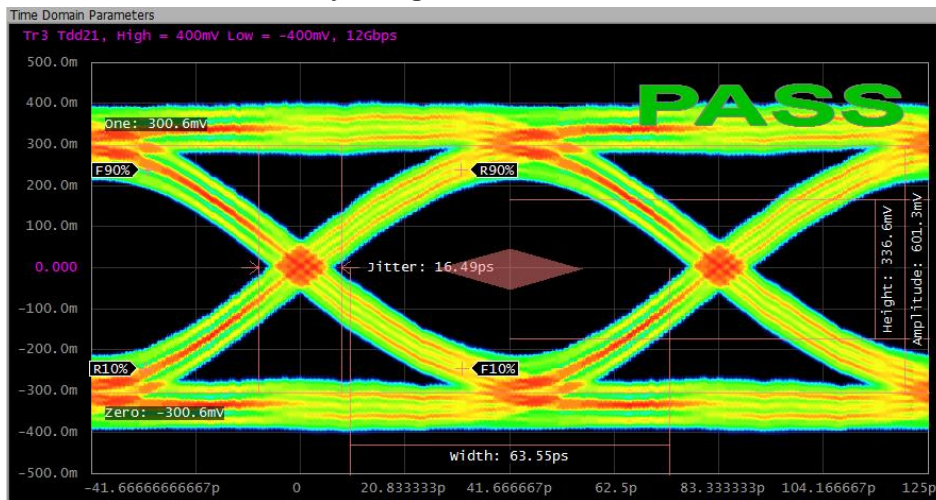

Data rate 12Gb/s

HDMI2.1 Eye Diagram with SY205237DVD

## Application Information

### Pin Connection in PCB

The SY205237DVD provides ESD protection for four data lines simultaneously. The pin connections are shown in Figure 2 below.

The four parallel data lines from the inner device to the IO port connector can connect directly to the four IO pins of the SY205237DVD. Pins 3 and 8 of the SY205237DVD are GND pins and should connect to the PCB ground. To minimize parasitic inductance, ensure the grounding trace is as short as possible.

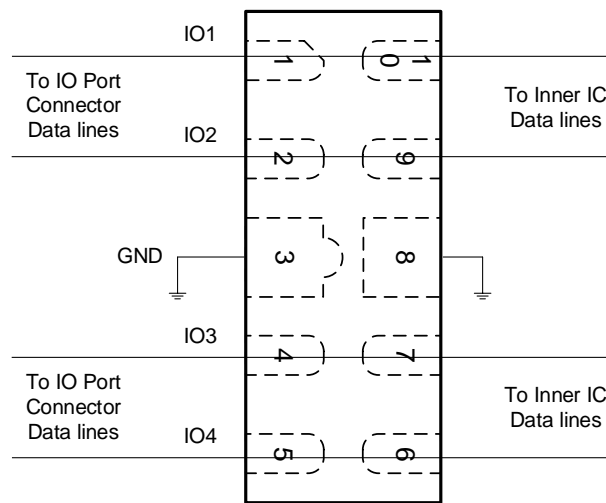

Figure 2 SY205237DVD Pin Connection in PCB

### PCB Layout Guidelines

For optimum ESD protection and circuit performance, the following PCB layout guidelines are recommended:

- The SY205237DVD GND pin to the PCB GND rail path should be as short as possible to reduce the ESD transient return path to GND.
- The vias connecting the SY205237DVD GND pins to the PCB GND should be wide.
- Place SY205237DVD as close to the connector port as possible to reduce parasitic inductance and restrict ESD coupling into adjacent traces.
- Avoid running critical signals near board edges.

## DFN2.5x1.0-10 Package Outline

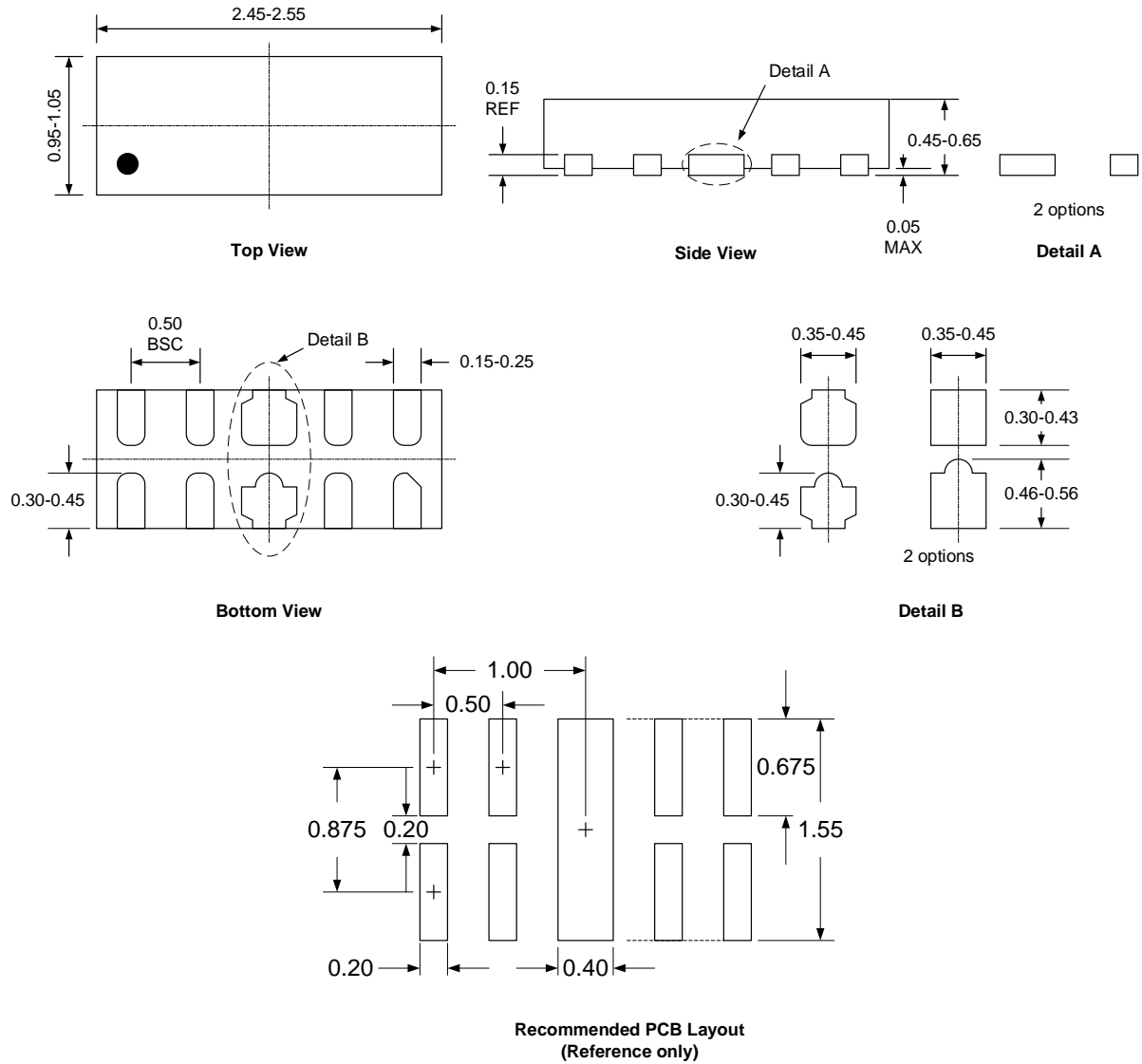

Note: All dimensions are in millimeters and exclude mold flash and metal burr.

## Tape and Reel Information

### Tape Dimensions and Pin 1 Orientation

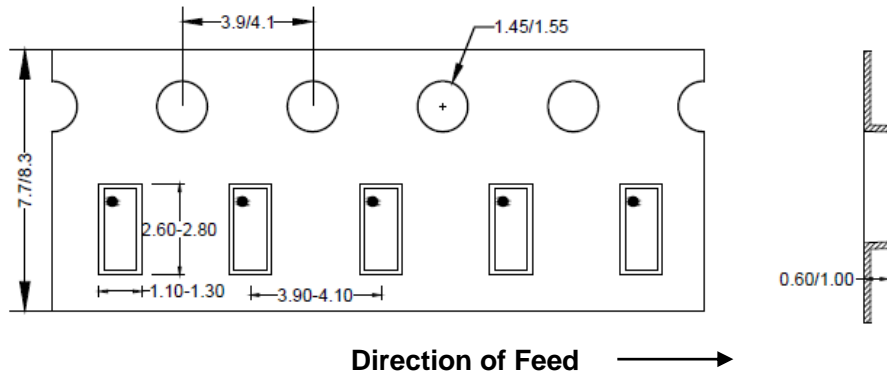

### Reel Dimensions

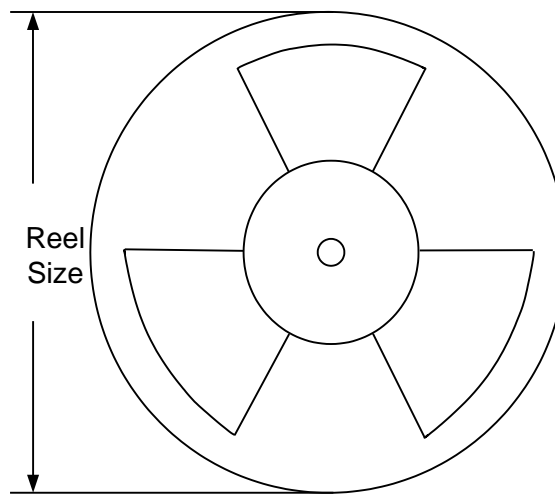

Package Type	Tape Width (mm)	Pocket Pitch(mm)	Reel Size (Inch)	Qty per Reel (pcs)
DFN2.5x1.0-10	8	4	7"	3000



---

### Revision History

The revision history provided is for informational purposes only and is believed to be accurate; however, not warranted. Please make sure that you have the latest revision.

Revision Number	Revision Date	Description	Pages changed
1.0	Sep. 13, 2024	Initial Release	

**IMPORTANT NOTICE**

- 1. Right to make changes.** Silergy and its subsidiaries (hereafter Silergy) reserve the right to change any information published in this document, including but not limited to circuitry, specification and/or product design, manufacturing or descriptions, at any time and without notice. This document supersedes and replaces all information supplied prior to the publication hereof. Buyers should obtain the latest relevant information before placing orders and should verify that such information is current and complete. All semiconductor products are sold subject to Silergy's standard terms and conditions of sale.
- 2. Applications.** Application examples that are described herein for any of these products are for illustrative purposes only. Silergy makes no representation or warranty that such applications will be suitable for the specified use without further testing or modification. Buyers are responsible for the design and operation of their applications and products using Silergy products. Silergy or its subsidiaries assume no liability for any application assistance or designs of customer products. It is customer's sole responsibility to determine whether the Silergy product is suitable and fit for the customer's applications and products planned. To minimize the risks associated with customer's products and applications, customer should provide adequate design and operating safeguards. Customer represents and agrees that it has all the necessary expertise to create and implement safeguards which anticipate dangerous consequences of failures, monitor failures and their consequences, lessen the likelihood of failures that might cause harm and take appropriate remedial actions. Silergy assumes no liability related to any default, damage, costs or problem in the customer's applications or products, or the application or use by customer's third-party buyers. Customer will fully indemnify Silergy, its subsidiaries, and their representatives against any damages arising out of the use of any Silergy components in safety-critical applications. It is also buyers' sole responsibility to warrant and guarantee that any intellectual property rights of a third party are not infringed upon when integrating Silergy products into any application. Silergy assumes no responsibility for any said applications or for any use of any circuitry other than circuitry entirely embodied in a Silergy product.
- 3. Limited warranty and liability.** Information furnished by Silergy in this document is believed to be accurate and reliable. However, Silergy makes no representation or warranty, expressed or implied, as to the accuracy or completeness of such information and shall have no liability for the consequences of use of such information. In no event shall Silergy be liable for any indirect, incidental, punitive, special or consequential damages, including but not limited to lost profits, lost savings, business interruption, costs related to the removal or replacement of any products or rework charges, whether or not such damages are based on tort or negligence, warranty, breach of contract or any other legal theory. Notwithstanding any damages that customer might incur for any reason whatsoever, Silergy' aggregate and cumulative liability towards customer for the products described herein shall be limited in accordance with the Standard Terms and Conditions of Sale of Silergy.
- 4. Suitability for use.** Customer acknowledges and agrees that it is solely responsible for compliance with all legal, regulatory and safety-related requirements concerning its products, and any use of Silergy components in its applications, notwithstanding any applications-related information or support that may be provided by Silergy. Silergy products are not designed, authorized or warranted to be suitable for use in life support, life-critical or safety-critical systems or equipment, nor in applications where failure or malfunction of a Silergy product can reasonably be expected to result in personal injury, death or severe property or environmental damage. Silergy assumes no liability for inclusion and/or use of Silergy products in such equipment or applications and therefore such inclusion and/or use is at the customer's own risk.
- 5. Terms and conditions of commercial sale.** Silergy products are sold subject to the standard terms and conditions of commercial sale, as published at <http://www.silergy.com>, unless otherwise agreed in a valid written individual agreement specifically agreed to in writing by an authorized officer of Silergy. In case an individual agreement is concluded only the terms and conditions of the respective agreement shall apply. Silergy hereby expressly objects to and denies the application of any customer's general terms and conditions with regard to the purchase of Silergy products by the customer.
- 6. No offer to sell or license.** Nothing in this document may be interpreted or construed as an offer to sell products that is open for acceptance or the grant, conveyance or implication of any license under any copyrights, patents or other industrial or intellectual property rights. Silergy makes no representation or warranty that any license, either express or implied, is granted under any patent right, copyright, mask work right, or other intellectual property right. Information published by Silergy regarding third-party products or services does not constitute a license to use such products or services or a warranty or endorsement thereof. Use of such information may require a license from a third party under the patents or other intellectual property of the third party, or a license from Silergy under the patents or other intellectual property of Silergy.

For more information, please visit: [www.silergy.com](http://www.silergy.com)

© 2024 Silergy Corp.

All Rights Reserved.