

### General Description

The SYCS233-3 is a family of high accuracy galvanically isolated Hall-effect current sensor ICs which bandwidth up to 0.7MHz. It adopts non-contact differential Hall array internally for bidirectional or unidirectional currents sensing from 10A to 75A, and outputs the analog voltage proportional to the DC or AC current. Current is sensed differentially in order to reject external common-mode fields.

A precise, proportional output voltage is provided by the high accuracy, good linearity, low temperature drift Hall IC, which is programmed for accuracy at the factory. It also provides user-configurable and reliable overcurrent fault detection.

The SYCS233-3 is available in a compact SOIC16 package with low primary conductor resistance for power loss, which allows for easy implementation.

The SYCS233-3 is suitable for high frequency, insulation, small size with low heat generation applications, including automotive, industrial, and communications systems.

### Features

- 3.3V Single Supply
- Wide Current Sensing Range:
  - Bidirectional:  $\pm 10 \sim \pm 75A$
  - Unidirectional:  $20 \sim 75A$
- 0.7MHz Typical Bandwidth, Response Time 0.7 $\mu s$
- UL62368-1 Ed3 certified
  - Dielectric Strength Test Voltage =  $3600V_{RMS}$
  - Working Voltage for Basic Isolation =  $616V_{RMS}$
- Fast and Externally Configurable Overcurrent Fault Detection
- Low Primary Conductor Resistance for Power Loss
- Factory-trimmed for High Accuracy
- Compact SOIC16 Package

### Applications

- EV/HEV Charger and DC-DC Power Supply
- Photovoltaic Inverter Power Supply and UPS
- Motor Control and Frequency Converter
- Communication and Server Power Supply

### Typical Application

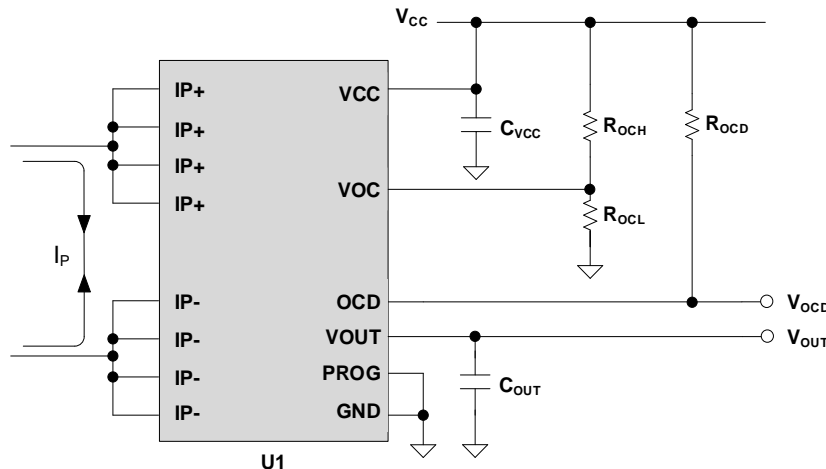

Figure 1. Typical Application Circuit



**SILERGY**

# SYCS233-3

## Ordering Information

Part Number	Architecture	I <sub>p</sub> (A)	Sensitivity(mV/A)	V <sub>qvo</sub> (V)	T <sub>A</sub> (°C)	MPQ(pcs)
SYCS233K-010BR-3	Bidirectional	±10	132	V <sub>CC</sub> /2	-40~125	440
SYCS233K-020BR-3	Bidirectional	±20	66	V <sub>CC</sub> /2	-40~125	440
SYCS233K-040BR-3	Bidirectional	±40	33	V <sub>CC</sub> /2	-40~125	440
SYCS233K-065BR-3	Bidirectional	±65	20.3	V <sub>CC</sub> /2	-40~125	440
SYCS233K-075BR-3	Unidirectional	±75	17.6	V <sub>CC</sub> /2	-40~125	440
SYCS233K-020UR-3	Unidirectional	20	132	V <sub>CC</sub> /10	-40~125	440
SYCS233K-040UR-3	Unidirectional	40	66	V <sub>CC</sub> /10	-40~125	440
SYCS233K-065UR-3	Unidirectional	65	40.6	V <sub>CC</sub> /10	-40~125	440
SYCS233K-075UR-3	Unidirectional	75	35.2	V <sub>CC</sub> /10	-40~125	440

## Pinout (Top View)

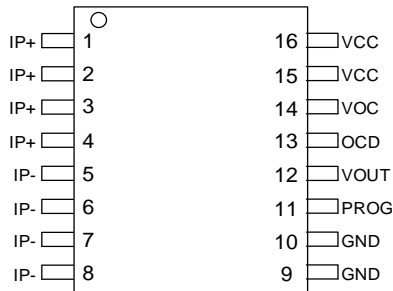

(SOIC 16)

Pin Number	Pin Name	Pin Description
1,2,3,4	IP+	Positive terminals for sensing current.
5,6,7,8	IP-	Negative terminals for sensing current.
9,10	GND	Ground pin.
11	PROG	Factory-trimmed pin. Connect this pin to GND.
12	VOUT	Analog output pin.
13	OCD	Overcurrent detection pin, open drain; active low.
14	VOC	Overcurrent fault threshold set pin.
15,16	VCC	Power supply pin.

## Block Diagram

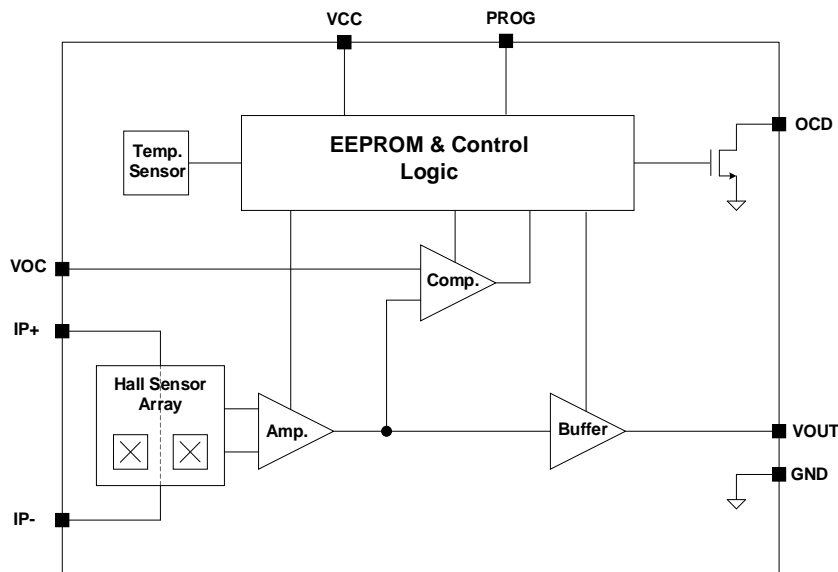

Figure 2. Block Diagram



**Absolute Maximum Ratings** (Note 1)

Supply Input Voltage ----- -0.3 to 4.6V

VOC, OCD, PROG, VOUT ----- 0.15 to V<sub>CC</sub>-0.15V

Output Current (Note 2) ----- ±40 mA

Junction Temperature Range ----- -40 to 165°C

Lead Temperature Range (Soldering, 10 sec.) ----- 260°C

Storage Temperature Range ----- -55 to 150°C

**Recommended Operating Conditions** (Note 3)

Supply Input Voltage ----- 4.5 to 5.5V

Ambient Temperature Range ----- -40 to 125°C

**Isolation Characteristics**

Characteristic	Symbol	Notes	Rating	Unit
Dielectric Strength Test Voltage (Note 4)	V <sub>ISO</sub>	Agency type-tested for 60 seconds per UL standard 62368-1 Ed3	3600	V <sub>RMS</sub>
Working Voltage for Basic Isolation	V <sub>WVBI</sub>	For basic (single) isolation per UL standard 62368-1 Ed3	870	V <sub>PK</sub>
			616	V <sub>RMS</sub>
Clearance Distance	D <sub>CL</sub>	Min distance from IP pin to signal pin(air)	7.5	mm
Creepage Distance	D <sub>CR</sub>	Min distance from IP pin to signal pin (molded body)	7.5	mm

## Electrical Characteristics

( $V_{CC} = 3.3V$ ,  $C_{VCC} = 0.1\mu F$ ,  $T_A = -40$  to  $125^\circ C$ , unless otherwise specified)

Parameter	Symbol	Test Conditions	Min	Typ.	Max	Unit
Supply Voltage	$V_{CC}$		3.14	3.3	3.46	V
Supply Current	$I_{CC}$	$R_L \geq 10k\Omega$		16		mA
Power on Delay Time	$T_{POD}$	$T_A = 25^\circ C$			1000	$\mu s$
Zero Current Output Voltage	$V_{QVO}$	SYCS-xxxBR, $T_A = 25^\circ C$		$V_{CC}/2$		V
		SYCS-xxxUR, $T_A = 25^\circ C$		$V_{CC}/10$		V
Output Voltage Range @ $I_P$	$V_{OUT} - V_{QVO}$	SYCS-xxxBR, $T_A = 25^\circ C$		$\pm 1.32$		V
		SYCS-xxxUR, $T_A = 25^\circ C$		2.64		V
Zero Current Output Ratiometry Error	$E_{RAT}$		-0.3		0.3	%
Output Load Resistance	$R_L$	$V_{OUT}$ to $V_{CC}$ or GND	5			k $\Omega$
Output Load Capacitance	$C_L$	$V_{OUT}$ to GND			10	nF
Response Time	$t_{RES}$	$T_A = 25^\circ C$ , $C_L = 1nF$ , step=50% of $I_P$ +, 90% input to 90% output		0.7		$\mu s$
Bandwidth	BW	Small signal -3dB, $C_L = 1nF$ , $T_A = 25^\circ C$		0.7	1	MHz
DC Output Impedance	$R_{OUT}$	$T_A = 25^\circ C$			20	k $\Omega$
Moisture Sensitivity Level	MSL			3		

## Overcurrent Fault Characteristics

( $V_{CC} = 3.3V$ ,  $C_{VCC} = 0.1\mu F$ ,  $T_A = -40$  to  $125^\circ C$ , unless otherwise specified)

Characteristic	Symbol	Test Conditions	Min.	Typ.	Max.	Unit
Overcurrent Detection Response Time	$t_{OCD, RES}$	Time from $I_P > I_{OCD}$ to $V_{OCD} < V_{OCD, FAU}$ ; $I_P$ stepped from 0 to $1.2 \times I_{OCD}$		0.8	1	$\mu s$
Overcurrent Detection Range	$I_{OCD}$	Relative to $I_P$ ; program via VOC pin	$0.5 \times I_P$		$2 \times I_P$	A
Overcurrent Detection Output Low Voltage	$V_{OCD, FAU}$	In fault condition; $R_{OCD} = 5k\Omega$		0.07	0.4	V
Overcurrent Detection Pull-Up Resistance	$R_{OCD}$		1		10	k $\Omega$
Overcurrent Detection Leakage Current	$I_{OCD, LKG}$			$\pm 5$		$\mu A$
Overcurrent Detection Hysteresis	$I_{OCD, HYS}$			9		%FS
Overcurrent Detection Error	$E_{OCD}$	$V_{VOC} = 0.2 \times V_{CC}$ , $I_{OCD} = 100\% \times I_{PR}$		$\pm 5$		%
VOC Input Range	$V_{VOC}$		$0.1 \times V_{CC}$		$0.4 \times V_{CC}$	V
VOC Input Current	$I_{VOC}$			10	100	nA

**Note 1:** Stresses beyond the “Absolute Maximum Ratings” may cause permanent damage to the device. These are stress ratings only. Functional operation of the device at these or any other conditions beyond those indicated in the operational sections of the specification is not implied. Exposure to absolute maximum rating conditions for extended periods may affect device reliability.

**Note 2:** Maximum survivable sink or source current on the VOUT pin.

**Note 3:** The device is not guaranteed to function outside its operating conditions.

**Note 4:** 60-second test is only for UL test; Tested in production against UL62368-1 Ed3.



SILERGY

# SYCS233-3

## SYCS233K-010BR-3 Performance Characteristics

(V<sub>CC</sub> = 3.3V, C<sub>VCC</sub> = 0.1μF, T<sub>A</sub> = -40 to 125°C, unless otherwise specified)

Parameter	Symbol	Condition	Min	Typ.	Max	Unit
<b>Nominal Performance</b>						
Current Sensing Range	I <sub>P</sub>		-10		10	A
Sensitivity	Sens			132		mV/A
Zero Current Output Voltage	V <sub>QVO</sub>	I <sub>P</sub> =0A		V <sub>CC</sub> /2		V
<b>Accuracy Performance</b>						
Sensitivity Error	E <sub>SENS</sub>	T <sub>A</sub> =25°C;	-1		1	%
Voltage Offset Error	V <sub>OE</sub>	I <sub>P</sub> =0A, T <sub>A</sub> = 25°C	-10	±5	10	mV
		I <sub>P</sub> =0A, T <sub>A</sub> = -40 to 125°C	-30	±15	30	mV
Linearity Error	E <sub>LIN</sub>	Full scale of I <sub>P</sub>	-1	0.5	1	%
Total Output Error	E <sub>TOT, H</sub>	Full scale of I <sub>P</sub> , T <sub>A</sub> = 25 to 125°C	-2		2	%
	E <sub>TOT, H2</sub>	Full scale of I <sub>P</sub> , T <sub>A</sub> = 25 to 85°C	-1.5		1.5	%
	E <sub>TOT, L</sub>	Full scale of I <sub>P</sub> , T <sub>A</sub> = -40 to 25°C		±3		%



**SYCS233K-020BR-3 Performance Characteristics**

( $V_{CC} = 3.3V$ ,  $C_{VCC} = 0.1\mu F$ ,  $T_A = -40$  to  $125^\circ C$ , unless otherwise specified)

Parameter	Symbol	Condition	Min	Typ.	Max	Unit
<b>Nominal Performance</b>						
Current Sensing Range	$I_P$		-20		20	A
Sensitivity	Sens			66		mV/A
Zero Current Output Voltage	$V_{QVO}$	$I_P=0A$		$V_{CC}/2$		V
<b>Accuracy Performance</b>						
Sensitivity Error	$E_{SENS}$	$T_A=25^\circ C$ ;	-1		1	%
Voltage Offset Error	$V_{OE}$	$I_P=0A, T_A = 25^\circ C$	-10	$\pm 5$	10	mV
		$I_P=0A, T_A = -40$ to $125^\circ C$	-30	$\pm 15$	30	mV
Linearity Error	$E_{LIN}$	Full scale of $I_P$	-1	0.5	1	%
Total Output Error	$E_{TOT, H}$	Full scale of $I_P$ , $T_A = 25$ to $125^\circ C$	-2		2	%
	$E_{TOT, H2}$	Full scale of $I_P$ , $T_A = 25$ to $85^\circ C$	-1.5		1.5	%
	$E_{TOT, L}$	Full scale of $I_P$ , $T_A = -40$ to $25^\circ C$		$\pm 3$		%

**SYCS233K-020UR-3 Performance Characteristics**

( $V_{CC} = 3.3V$ ,  $C_{VCC} = 0.1\mu F$ ,  $T_A = -40$  to  $125^\circ C$ , unless otherwise specified)

Parameter	Symbol	Condition	Min	Typ.	Max	Unit
<b>Nominal Performance</b>						
Current Sensing Range	$I_P$		0		20	A
Sensitivity	Sens			132		mV/A
Zero Current Output Voltage	$V_{QVO}$	$I_P=0A$		$V_{CC}/10$		V
<b>Accuracy Performance</b>						
Sensitivity Error	$E_{SENS}$	$T_A=25^\circ C$ ;	-1		1	%
Voltage Offset Error	$V_{OE}$	$I_P=0A, T_A = 25^\circ C$	-10	$\pm 5$	10	mV
		$I_P=0A, T_A = -40$ to $125^\circ C$	-30	$\pm 15$	30	mV
Linearity Error	$E_{LIN}$	Full scale of $I_P$	-1	0.5	1	%
Total Output Error	$E_{TOT, H}$	Full scale of $I_P$ , $T_A = 25$ to $125^\circ C$	-2		2	%
	$E_{TOT, H2}$	Full scale of $I_P$ , $T_A = 25$ to $85^\circ C$	-1.5		1.5	%
	$E_{TOT, L}$	Full scale of $I_P$ , $T_A = -40$ to $25^\circ C$		$\pm 3$		%

## SYCS233K-040BR-3 Performance Characteristics

( $V_{CC} = 3.3V$ ,  $C_{VCC} = 0.1\mu F$ ,  $T_A = -40$  to  $125^\circ C$ , unless otherwise specified)

Parameter	Symbol	Condition	Min	Typ.	Max	Unit
<b>Nominal Performance</b>						
Current Sensing Range	$I_P$		-40		40	A
Sensitivity	Sens			33		mV/A
Zero Current Output Voltage	$V_{QVO}$	$I_P=0A$		$V_{CC}/2$		V
<b>Accuracy Performance</b>						
Sensitivity Error	$E_{SENS}$	$T_A=25^\circ C$ ;	-1		1	%
Voltage Offset Error	$V_{OE}$	$I_P=0A, T_A = 25^\circ C$	-10	$\pm 5$	10	mV
		$I_P=0A, T_A = -40$ to $125^\circ C$	-30	$\pm 15$	30	mV
Linearity Error	$E_{LIN}$	Full scale of $I_P$	-1	0.5	1	%
Total Output Error	$E_{TOT, H}$	Full scale of $I_P$ , $T_A = 25$ to $125^\circ C$	-2		2	%
	$E_{TOT, H2}$	Full scale of $I_P$ , $T_A = 25$ to $85^\circ C$	-1.5		1.5	%
	$E_{TOT, L}$	Full scale of $I_P$ , $T_A = -40$ to $25^\circ C$		$\pm 3$		%

## SYCS233K-040UR-3 Performance Characteristics

( $V_{CC} = 3.3V$ ,  $C_{VCC} = 0.1\mu F$ ,  $T_A = -40$  to  $125^\circ C$ , unless otherwise specified)

Parameter	Symbol	Condition	Min	Typ.	Max	Unit
<b>Nominal Performance</b>						
Current Sensing Range	$I_P$		0		40	A
Sensitivity	Sens			66		mV/A
Zero Current Output Voltage	$V_{QVO}$	$I_P=0A$		$V_{CC}/10$		V
<b>Accuracy Performance</b>						
Sensitivity Error	$E_{SENS}$	$T_A=25^\circ C$ ;	-1		1	%
Voltage Offset Error	$V_{OE}$	$I_P=0A, T_A = 25^\circ C$	-10	$\pm 5$	10	mV
		$I_P=0A, T_A = -40$ to $125^\circ C$	-30	$\pm 15$	30	mV
Linearity Error	$E_{LIN}$	Full scale of $I_P$	-1	0.5	1	%
Total Output Error	$E_{TOT, H}$	Full scale of $I_P$ , $T_A = 25$ to $125^\circ C$	-2		2	%
	$E_{TOT, H2}$	Full scale of $I_P$ , $T_A = 25$ to $85^\circ C$	-1.5		1.5	%
	$E_{TOT, L}$	Full scale of $I_P$ , $T_A = -40$ to $25^\circ C$		$\pm 3$		%

## SYCS233K-065BR-3 Performance Characteristics

( $V_{CC} = 3.3V$ ,  $C_{VCC} = 0.1\mu F$ ,  $T_A = -40$  to  $125^\circ C$ , unless otherwise specified)

Parameter	Symbol	Condition	Min	Typ.	Max	Unit
<b>Nominal Performance</b>						
Current Sensing Range	$I_P$		-65		65	A
Sensitivity	Sens			20.3		mV/A
Zero Current Output Voltage	$V_{QVO}$	$I_P=0A$		$V_{CC}/2$		V
<b>Accuracy Performance</b>						
Sensitivity Error	$E_{SENS}$	$T_A=25^\circ C$ ;	-1		1	%
Voltage Offset Error	$V_{OE}$	$I_P=0A, T_A = 25^\circ C$	-10	$\pm 5$	10	mV
		$I_P=0A, T_A = -40$ to $125^\circ C$	-30	$\pm 15$	30	mV
Linearity Error	$E_{LIN}$	Full scale of $I_P$	-1	0.5	1	%
Total Output Error	$E_{TOT, H}$	Full scale of $I_P$ , $T_A = 25$ to $125^\circ C$	-2		2	%
	$E_{TOT, H2}$	Full scale of $I_P$ , $T_A = 25$ to $85^\circ C$	-1.5		1.5	%
	$E_{TOT, L}$	Full scale of $I_P$ , $T_A = -40$ to $25^\circ C$		$\pm 3$		%

## SYCS233K-065UR-3 Performance Characteristics

( $V_{CC} = 3.3V$ ,  $C_{VCC} = 0.1\mu F$ ,  $T_A = -40$  to  $125^\circ C$ , unless otherwise specified)

Parameter	Symbol	Condition	Min	Typ.	Max	Unit
<b>Nominal Performance</b>						
Current Sensing Range	$I_P$		0		65	A
Sensitivity	Sens			40.6		mV/A
Zero Current Output Voltage	$V_{QVO}$	$I_P=0A$		$V_{CC}/10$		V
<b>Accuracy Performance</b>						
Sensitivity Error	$E_{SENS}$	$T_A=25^\circ C$ ;	-1		1	%
Voltage Offset Error	$V_{OE}$	$I_P=0A, T_A = 25^\circ C$	-10	$\pm 5$	10	mV
		$I_P=0A, T_A = -40$ to $125^\circ C$	-30	$\pm 15$	30	mV
Linearity Error	$E_{LIN}$	Full scale of $I_P$	-1	0.5	1	%
Total Output Error	$E_{TOT, H}$	Full scale of $I_P$ , $T_A = 25$ to $125^\circ C$	-2		2	%
	$E_{TOT, H2}$	Full scale of $I_P$ , $T_A = 25$ to $85^\circ C$	-1.5		1.5	%
	$E_{TOT, L}$	Full scale of $I_P$ , $T_A = -40$ to $25^\circ C$		$\pm 3$		%



**SYCS233K-075BR-3 Performance Characteristics**

(V<sub>CC</sub> = 3.3V, C<sub>VCC</sub> = 0.1μF, T<sub>A</sub> = -40 to 125°C, unless otherwise specified)

Parameter	Symbol	Condition	Min	Typ.	Max	Unit
<b>Nominal Performance</b>						
Current Sensing Range	I <sub>P</sub>		-75		75	A
Sensitivity	Sens			17.6		mV/A
Zero Current Output Voltage	V <sub>QVO</sub>	I <sub>P</sub> =0A		V <sub>CC</sub> /2		V
<b>Accuracy Performance</b>						
Sensitivity Error	E <sub>SENS</sub>	T <sub>A</sub> =25°C;	-2		2	%
Voltage Offset Error	V <sub>OE</sub>	I <sub>P</sub> =0A, T <sub>A</sub> = 25°C	-10	±5	10	mV
		I <sub>P</sub> =0A, T <sub>A</sub> = -40 to 125°C	-30	±15	30	mV
Linearity Error	E <sub>LIN</sub>	Full scale of I <sub>P</sub>	-1.5	0.5	1.5	%
Total Output Error	E <sub>TOT, H</sub>	Full scale of I <sub>P</sub> , T <sub>A</sub> = 25 to 125°C	-3		3	%
	E <sub>TOT, H2</sub>	Full scale of I <sub>P</sub> , T <sub>A</sub> = 25 to 85°C	-2		2	%
	E <sub>TOT, L</sub>	Full scale of I <sub>P</sub> , T <sub>A</sub> = -40 to 25°C		±3		%

**SYCS233K-075UR-3 Performance Characteristics**

(V<sub>CC</sub> = 3.3V, C<sub>VCC</sub> = 0.1μF, T<sub>A</sub> = -40 to 125°C, unless otherwise specified)

Parameter	Symbol	Condition	Min	Typ.	Max	Unit
<b>Nominal Performance</b>						
Current Sensing Range	I <sub>P</sub>		0		75	A
Sensitivity	Sens			35.2		mV/A
Zero Current Output Voltage	V <sub>QVO</sub>	I <sub>P</sub> =0A		V <sub>CC</sub> /10		V
<b>Accuracy Performance</b>						
Sensitivity Error	E <sub>SENS</sub>	T <sub>A</sub> =25°C;	-2		2	%
Voltage Offset Error	V <sub>OE</sub>	I <sub>P</sub> =0A, T <sub>A</sub> = 25°C	-10	±5	10	mV
		I <sub>P</sub> =0A, T <sub>A</sub> = -40 to 125°C	-30	±15	30	mV
Linearity Error	E <sub>LIN</sub>	Full scale of I <sub>P</sub>	-1.5	0.5	1.5	%
Total Output Error	E <sub>TOT, H</sub>	Full scale of I <sub>P</sub> , T <sub>A</sub> = 25 to 125°C	-3		3	%
	E <sub>TOT, H2</sub>	Full scale of I <sub>P</sub> , T <sub>A</sub> = 25 to 85°C	-2		2	%
	E <sub>TOT, L</sub>	Full scale of I <sub>P</sub> , T <sub>A</sub> = -40 to 25°C		±3		%

## Operation

The SYCS233-3 is a family of high accuracy galvanically isolated current sensor ICs. It offers high isolation, high bandwidth Hall-effect-based current sensing with user-configurable overcurrent fault detection.

There are various output modes for measuring bidirectional or unidirectional current from 10A to 75A, which output the analog voltage proportional to the AC or DC current. The bandwidth is up to 0.7MHz.

The SYCS233-3 is available in a compact SOIC16 package.

## Application Information

### Power Supply Capacitor (C<sub>VCC</sub>)

To minimize the potential noise problem, place a typical X5R or better grade ceramic capacitor really close to the IN and GND pins. In this case, a 0.1μF or larger low ESR ceramic capacitor is recommended.

### Output Capacitor (C<sub>OUT</sub>)

The output capacitor is selected to handle the output noise requirements. An X5R or better grade ceramic capacitor close to the V<sub>OUT</sub> and GND pins can work well. To achieve better filtering results, a resistor (R<sub>OUT</sub>) can be added. The values of C<sub>OUT</sub> and R<sub>OUT</sub> are depended on the application. For most applications, a 10nF ceramic capacitor can operate well.

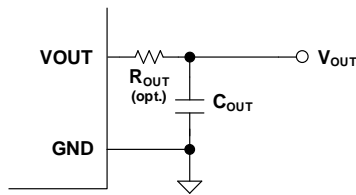

Figure 3. Output Capacitor

### Sensitivity (Sens)

Sensitivity is the slope of the approximate straight line between the output voltage (V<sub>OUT</sub>) and the input primary current (I<sub>P</sub>) within the sensing range. V<sub>QVO</sub> is the quiescent voltage output.

$$V_{OUT} = V_{QVO} + Sens \times I_P$$

### Response Time (t<sub>RES</sub>)

Response time (t<sub>RES</sub>) is defined as the time delay from the 90% of input primary current (I<sub>P</sub>) to the 90% of the output voltage (V<sub>OUT</sub>).

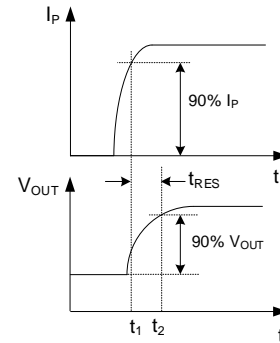

Figure 4. Response Time

### Quiescent Voltage Output (V<sub>QVO</sub>)

The V<sub>QVO</sub> is defined as the output voltage (V<sub>OUT</sub>) when the primary current (I<sub>P</sub>) is zero, which is related to the V<sub>CC</sub>.

For the bidirectional current sensor IC,

$$V_{QVO} = \frac{1}{2} \times V_{CC}$$

For the unidirectional current sensor IC,

$$V_{QVO} = \frac{1}{10} \times V_{CC}$$

### Voltage Offset Error (V<sub>OE</sub>)

The voltage offset error (V<sub>OE</sub>) is defined as the deviation of the zero current output voltage from its ideal quiescent value (V<sub>QVO</sub>), due to nonmagnetic causes.

### Zero Current Output Ratiometric Error (E<sub>RAT</sub>)

When the supply voltage V<sub>CC</sub> changes from the typical value (V<sub>CC, TYP</sub>) to V<sub>CC, MIN</sub> < V<sub>CC, M</sub> < V<sub>CC, MAX</sub> there will be a certain deviation between the measured zero current output (V<sub>QVO, M</sub>) and its ideal value (V<sub>QVO, TYP</sub>), which is defined as follows:

$$E_{RAT} = 1 - \frac{V_{QVO, M}}{V_{CC, M}} \times \frac{V_{CC, TYP}}{V_{QVO, TYP}}$$

### Linearity Error (E<sub>LIN</sub>)

The linearity error (E<sub>LIN</sub>) is the maximum positive or negative error between the measured output voltage and the ideal value within the sensing range.

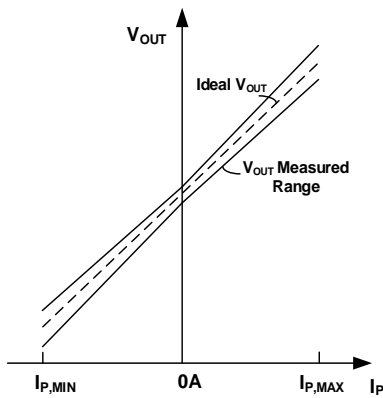

Figure 5. Linearity Error

### Total Output Error (E<sub>TOT</sub>)

Total output error (E<sub>TOT</sub>) is defined as the difference between the ideal output voltage (V<sub>OUT</sub>) and the actual output voltage (V<sub>OUT, IP</sub>), divided by the ideal sensitivity (Sens), relative to the primary current (I<sub>P</sub>) flowing through the primary conduction path:

$$E_{TOT} = \frac{V_{OUT,IP} - V_{OUT}}{Sens \times I_P}$$

At relatively high current, E<sub>TOT</sub> will be mostly due to sensitivity errors; but at relatively low current, E<sub>TOT</sub> will be mostly due to the voltage offset error (V<sub>OE</sub>). As the primary current (I<sub>P</sub>) approaches zero, the E<sub>TOT</sub> approaches infinity due to the voltage offset error (V<sub>OE</sub>).

### Overcurrent Detection (OCD)

The overcurrent detection is user-configurable from 50% to 200% of the full-scale primary input current which is shown below.

For example, if V<sub>VOC</sub>=0.4×V<sub>CC</sub>, the overcurrent threshold(I<sub>OCD</sub>) is double of maximum primary current range(I<sub>P,MAX</sub>). And for bidirectional current application, the fault will trip for both positive and negative current.

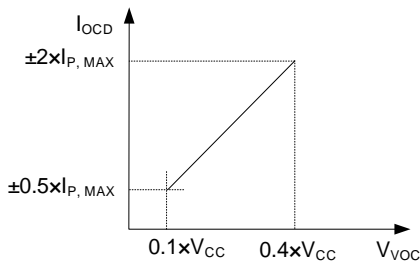

Figure 6. Overcurrent Detection Threshold

### VOC Resistor Dividers R<sub>OCH</sub> and R<sub>OCL</sub>

Choose R<sub>OCH</sub> and R<sub>OCL</sub> to program the proper overcurrent detection threshold. As shown below, V<sub>1</sub> is an external

power source, which is recommended to connect it to the V<sub>CC</sub> to remain constant even as the V<sub>CC</sub> varies. It is recommended to use resistor values <10kΩ for setting V<sub>VOC</sub> and 5kΩ for pulling up V<sub>OCD</sub> when V<sub>1</sub>=V<sub>2</sub>=V<sub>CC</sub>. With larger resistor values, the leakage current may result in errors in the trip point. The R<sub>OCH</sub> and R<sub>OCL</sub> can be calculated to be:

$$\frac{R_{OCL}}{R_{OCH} + R_{OCL}} = \frac{1}{5} \times \frac{V_{CC}}{V_1} \times \frac{I_{OCD}}{I_{PR,MAX}}$$

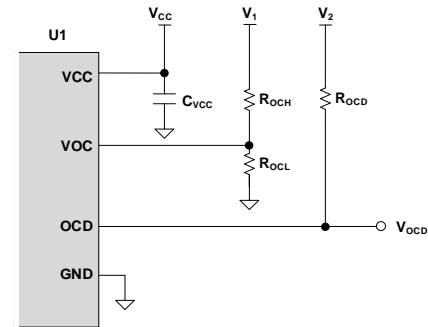

Figure 7. Overcurrent Detection Circuit

The OCD pin is open drain that the default value is high-Z. It drops down when the absolute value of primary current (|I<sub>P</sub>|) exceeds the user-set overcurrent threshold (I<sub>OCD</sub>), and rise up when the I<sub>P</sub> smaller than the user-set I<sub>OCD</sub> minus overcurrent detection hysteresis (I<sub>OCD, HYS</sub>). The high and low voltage of VOC pin are related to the pull-up voltage (V<sub>2</sub>).

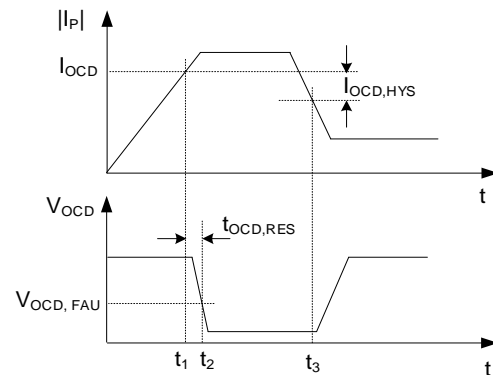

Figure 8. Overcurrent Detection Response

### Layout Design

The layout design of the SYCS233-3 is relatively simple. For the best performance, the attention should be paid to heat dissipation and traces.

1. It is best practice for the current to approach the IC parallel to the current-carrying pins, and for the current-carrying trace to not creep towards the center of the package.

2. It is best to place  $C_{VCC}$  and  $C_L$  close to the IC to achieve better filtering performance.

3. If in some application scenarios, the  $V_{CC}$  pin has an instantaneous pulse peak of more than 6.5V, it is recommended to install a TVS (Transient Voltage Suppressor) diode between  $V_{CC}$  pin and GND pin to absorb the spike energy.

4. It is important to implement proper current path planning, as this constitutes a critical measure for effective magnetic interference suppression. The recommended PCB layout is as follows. In terms of details, for better performance, it is recommended to use PCB with minimum 2-ounce copper foil, at least 4-layer board, and place thermal vias near primary current pins.

*Figure 9. Recommended PCB Layout*

Bad PCB layout will degrade isolation performance. The following design is NOT recommended.

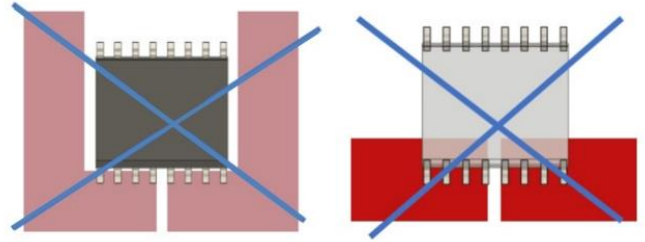

*Figure 10. Not Recommended PCB Layout*

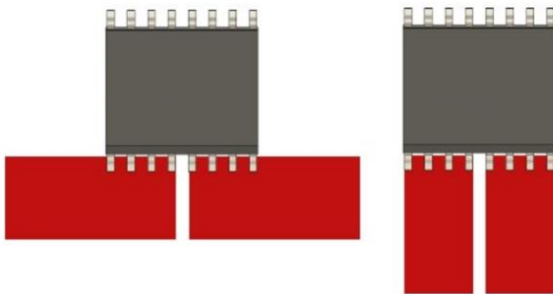

## Packaging Quantity Specifications

44 Pcs/Tube

80 Tubes/Box  
3520 Pcs/Box

6 Boxes/Carton  
21120 Pcs/Carton

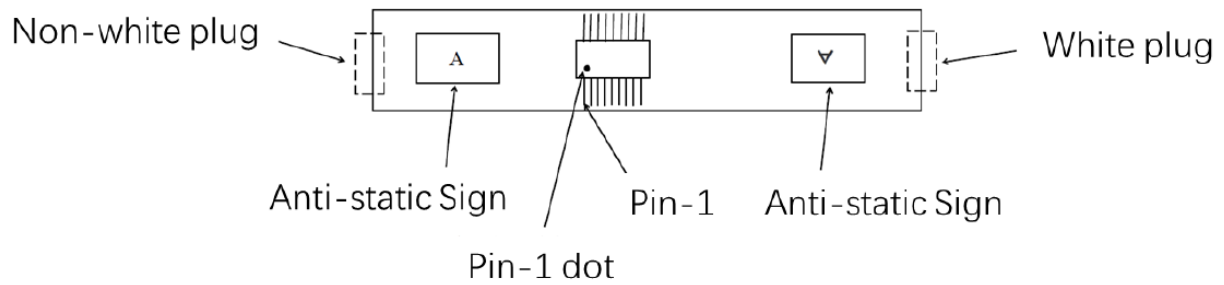
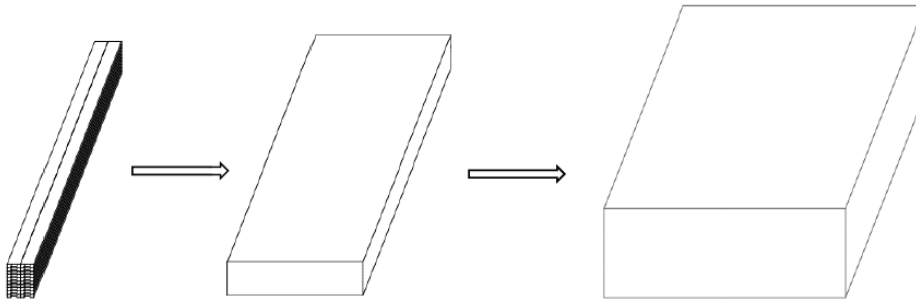

## Package Outline & PCB Layout Design

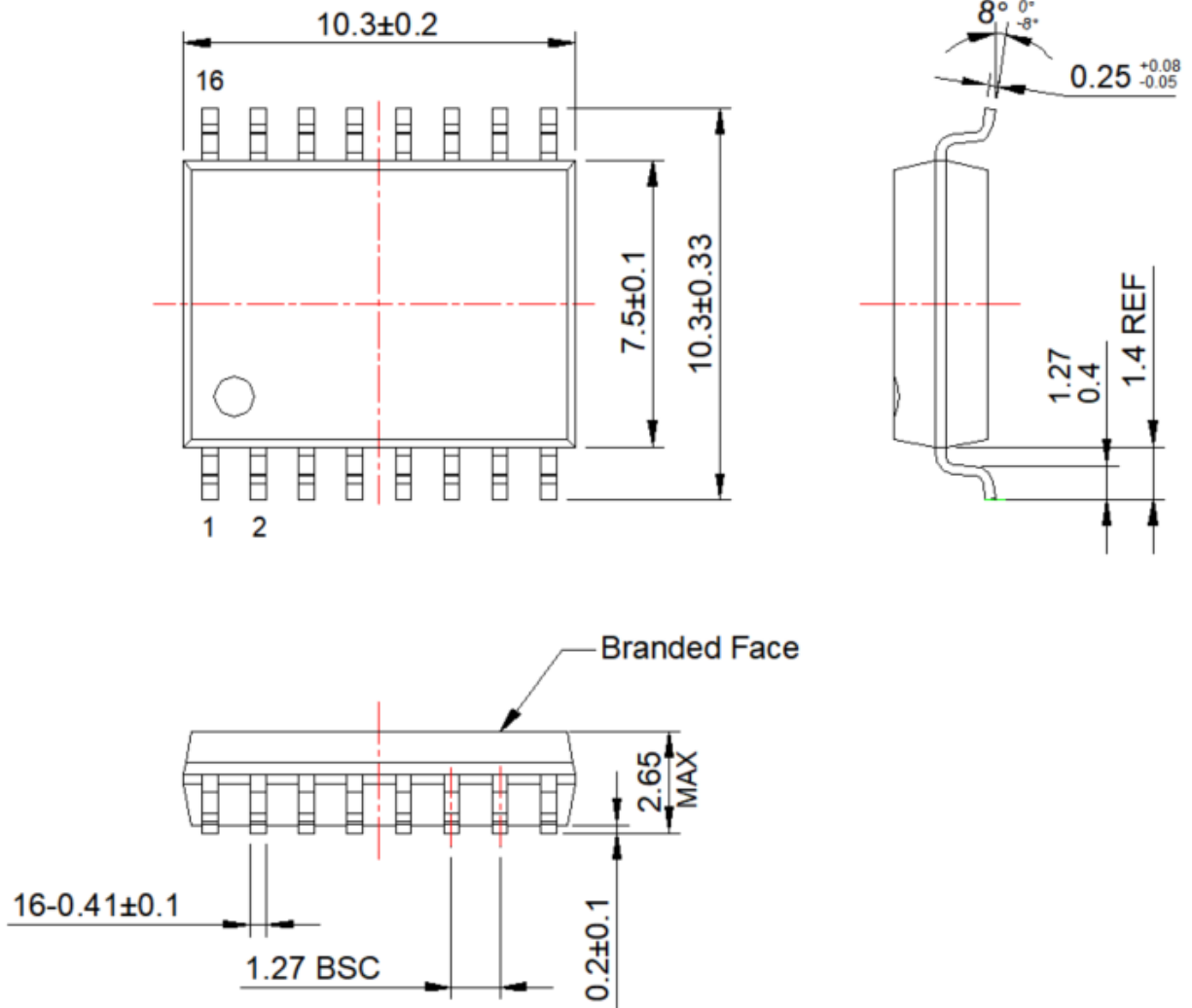

## Storage Conditions

1. We suggest that the element must be stored at an appropriate temperature 5 ~ 40°C and Relative humidity 40 ~ 60%RH.
2. Please keep the element away from the following circumstance: (Because store the products under the following circumstance, will cause appearance damage, characteristic defectiveness and inferior assembly etc)
  - 1) Under high temperature, high humidity circumstance for long time
  - 2) With corrosive gas, oxidation gas, acidity / alkalinity circumstance.
  - 3) dusty circumstance
3. Long-term storage may result in poor lead solderability and degraded electrical performance.
4. After unpacking, it should be stored in a dry environment with a relative humidity of less than 60% and a temperature controlled between 5°C and 30°C. It is recommended to complete welding within 168 hours after unpacking. If it exceeds 168 hours, it is recommended to re bake before use or repackage.

## Soldering Conditions

### Suggestion conditions for soldering to PCB:

- 1) Avoid rapid heating, rapid cooling.
- 2) Preheat at temperature 130~150°C for 2~3 minutes.
- 3) Best condition of soldering (For example reflow): at 230~250°C for 3~5 secs.

### Soldering Method and Guarantee Temperature

#### 1) Soldering Method

Method	Method Description	Temperature
Reflow soldering	Soldering at high temperature environment	MAX260°C within 10secs
Dip soldering	Soldering at dipping solder sink	MAX260°C within 10secs
Hand soldering	Soldering lead of element by searing-iron	MAX350°C within 3secs

#### 2) Guarantee Temperature Range

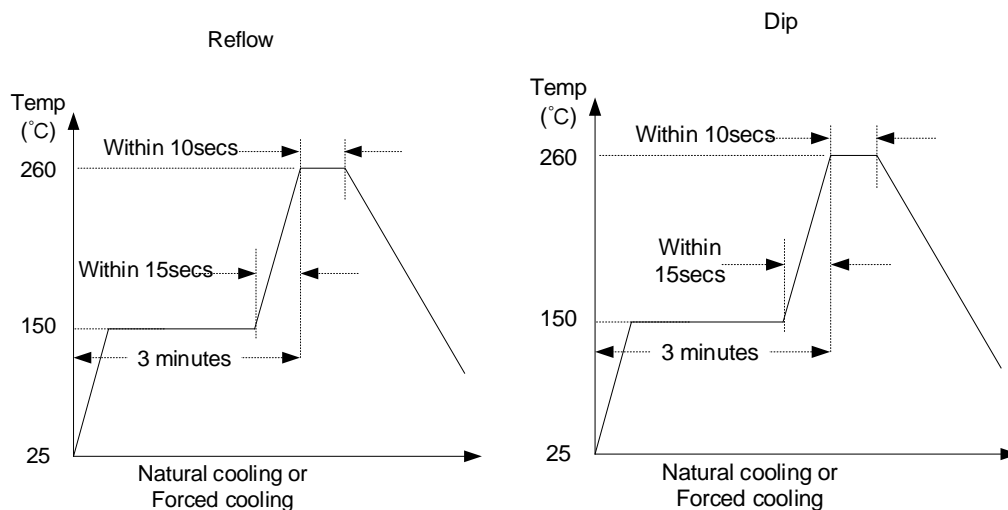

#### Guarantee Value (at Max. temperature)

Method	Reflow	Dip
Temperature	260°C	260°C
Time	10 seconds	10 seconds



---

### **Revision History**

The revision history provided is for informational purposes only and is believed to be accurate; however, not warranted. Please make sure that you have the latest revision.

<b>Revision Number</b>	<b>Revision Date</b>	<b>Description</b>	<b>Pages changed</b>
1.0	Aug. 19, 2025	Initial Release	



## IMPORTANT NOTICE

- 1. Right to make changes.** Silergy and its subsidiaries (hereafter Silergy) reserve the right to change any information published in this document, including but not limited to circuitry, specification and/or product design, manufacturing or descriptions, at any time and without notice. This document supersedes and replaces all information supplied prior to the publication hereof. Buyers should obtain the latest relevant information before placing orders and should verify that such information is current and complete. All semiconductor products are sold subject to Silergy's standard terms and conditions of sale.
- 2. Applications.** Application examples that are described herein for any of these products are for illustrative purposes only. Silergy makes no representation or warranty that such applications will be suitable for the specified use without further testing or modification. Buyers are responsible for the design and operation of their applications and products using Silergy products. Silergy or its subsidiaries assume no liability for any application assistance or designs of customer products. It is customer's sole responsibility to determine whether the Silergy product is suitable and fit for the customer's applications and products planned. To minimize the risks associated with customer's products and applications, customer should provide adequate design and operating safeguards. Customer represents and agrees that it has all the necessary expertise to create and implement safeguards which anticipate dangerous consequences of failures, monitor failures and their consequences, lessen the likelihood of failures that might cause harm and take appropriate remedial actions. Silergy assumes no liability related to any default, damage, costs or problem in the customer's applications or products, or the application or use by customer's third-party buyers. Customer will fully indemnify Silergy, its subsidiaries, and their representatives against any damages arising out of the use of any Silergy components in safety-critical applications. It is also buyers' sole responsibility to warrant and guarantee that any intellectual property rights of a third party are not infringed upon when integrating Silergy products into any application. Silergy assumes no responsibility for any said applications or for any use of any circuitry other than circuitry entirely embodied in a Silergy product.
- 3. Limited warranty and liability.** Information furnished by Silergy in this document is believed to be accurate and reliable. However, Silergy makes no representation or warranty, expressed or implied, as to the accuracy or completeness of such information and shall have no liability for the consequences of use of such information. In no event shall Silergy be liable for any indirect, incidental, punitive, special or consequential damages, including but not limited to lost profits, lost savings, business interruption, costs related to the removal or replacement of any products or rework charges, whether or not such damages are based on tort or negligence, warranty, breach of contract or any other legal theory. Notwithstanding any damages that customer might incur for any reason whatsoever, Silergy' aggregate and cumulative liability towards customer for the products described herein shall be limited in accordance with the Standard Terms and Conditions of Sale of Silergy.
- 4. Suitability for use.** Customer acknowledges and agrees that it is solely responsible for compliance with all legal, regulatory and safety-related requirements concerning its products, and any use of Silergy components in its applications, notwithstanding any applications-related information or support that may be provided by Silergy. Silergy products are not designed, authorized or warranted to be suitable for use in life support, life-critical or safety-critical systems or equipment, nor in applications where failure or malfunction of a Silergy product can reasonably be expected to result in personal injury, death or severe property or environmental damage. Silergy assumes no liability for inclusion and/or use of Silergy products in such equipment or applications and therefore such inclusion and/or use is at the customer's own risk.
- 5. Terms and conditions of commercial sale.** Silergy products are sold subject to the standard terms and conditions of commercial sale, as published at <http://www.silergy.com>, unless otherwise agreed in a valid written individual agreement specifically agreed to in writing by an authorized officer of Silergy. In case an individual agreement is concluded only the terms and conditions of the respective agreement shall apply. Silergy hereby expressly objects to and denies the application of any customer's general terms and conditions with regard to the purchase of Silergy products by the customer.
- 6. No offer to sell or license.** Nothing in this document may be interpreted or construed as an offer to sell products that is open for acceptance or the grant, conveyance or implication of any license under any copyrights, patents or other industrial or intellectual property rights. Silergy makes no representation or warranty that any license, either express or implied, is granted under any patent right, copyright, mask work right, or other intellectual property right. Information published by Silergy regarding third-party products or services does not constitute a license to use such products or services or a warranty or endorsement thereof. Use of such information may require a license from a third party under the patents or other intellectual property of the third party, or a license from Silergy under the patents or other intellectual property of Silergy.

For more information, please visit: [www.silergy.com](http://www.silergy.com)

© 2025 Silergy Corp.

All Rights Reserved.