

5.5V, High Efficiency Synchronous Boost Regulator with Bypass Mode

General Description

The SY87004A is a high efficiency, synchronous boost converter with bypass mode. The device is designed to operate in bypass mode by providing a low resistance path between the output and input when the input voltage is higher than the target voltage. It transition automatically into boost mode when the input voltage is lower than the desired output.

The SY87004A operates over a wide input voltage range from 1.9V to 5.5V and supports up to 6A maximum load current in bypass mode.

Overtemperature, overcurrent, as well as output undervoltage and input overvoltage protections are provided reliable operation.

The device operation and parameters can be configured using the I²C bus.

The SY87004A is available in a compact CSP 1.65mm×1.65mm-16 bump package.

Features

- Input Voltage Range: 1.9V to 5.5V
- Program Output Range: 2.85V to 5.5V
- Maximum Bypass Continuous Load Current :6A
- Up to 95% Efficiency
- Supports 0.9V signaling for SCL/SDA/EN Pins
- Programmable Valley Inductor Current Limit and Output Voltage
- I²C Configurable Auto Bypass Operation And Forced Bypass Mode
- I²C configurable FCCM and PFM Modes
- Low Operating Quiescent Current
- Shutdown Current 0.1 μ A (Typ.)
- Load Disconnect During Shutdown
- Compact Package CSP1.65×1.65-16
- Moisture Sensitivity Level (MSL): 1

Applications

- Single-Cell Li-Ion, LiFePO4 Smart-Phones or Tablet PCs
- 2.5G/3G/4G Data Cards

Typical Application

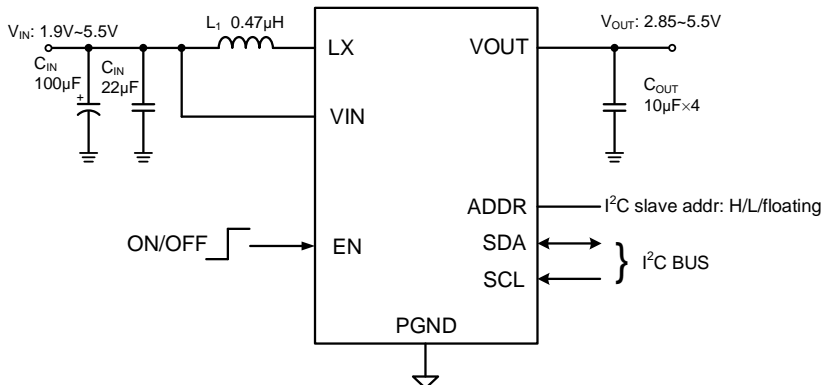

Figure 1. Schematic Diagram

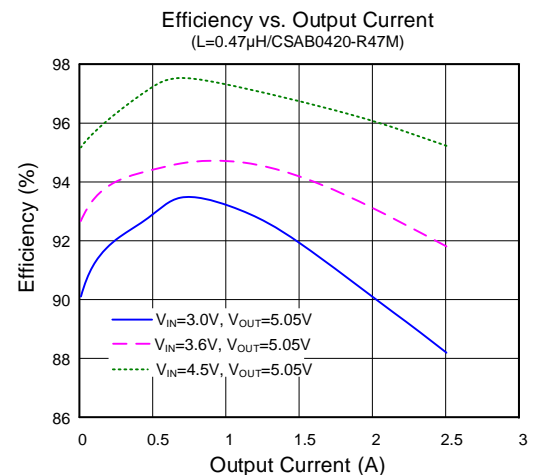

Figure 2. Efficiency vs. Output Current

Ordering Information

Ordering Part Number	Package Type	Top Mark
SY87004AWUS	CSP1.65×1.65-16 RoHS-Compliant, Halogen-Free	LWXxyz

Device code: LWX

x=year code, y=week code, z=lot number code

Pinout (top view)

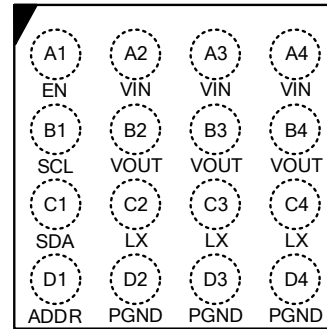

Pin Description

Pin Name	Pin Number	Pin Description
EN	A1	Enable pin. Active high, do not leave floating.
VIN	A2, A3, A4	Input pin. Decouple this pin to the GND with at least a 4.7μF ceramic capacitor.
SCL	B1	I ² C interface serial clock line. Logic level input.
VOUT	B2, B3, B4	Output voltage pin. Decouple this pin to PGND with at least 4x10μF ceramic capacitors.
SDA	C1	I ² C interface serial data line. Logic level input/output.
LX	C2, C3, C4	Switching node pin. Connect these pins to the switching node of inductor.
ADDR	D1	I ² C slave address pin. This pin can be pulled high, low or left floating to change the peripheral address.
PGND	D2, D3, D4	Power ground.

Function Block

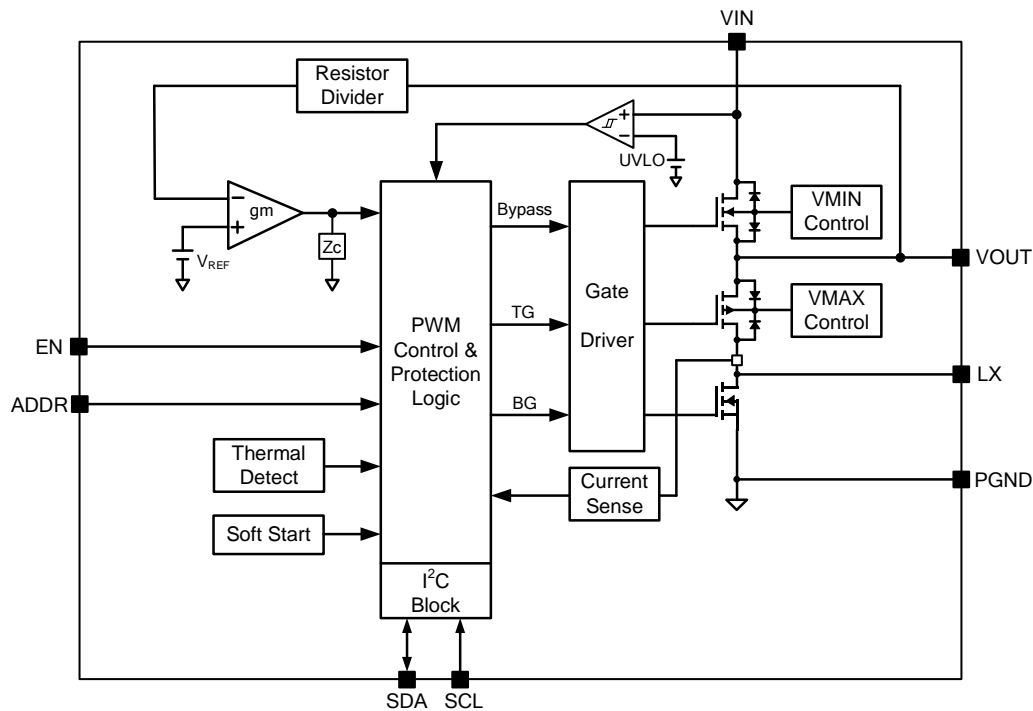

Figure3. Block Diagram

Absolute Maximum Ratings

Parameter (Note 1)		Min	Max	Unit
VIN		-0.3	6	V
SCL, SDA, ADDR		-0.3	6	
EN, VOUT, LX		-0.3	6	
Lead Temperature (Soldering, 10 sec.)			260	°C
Junction Temperature, Operating		-40	150	
Storage Temperature		-65	150	
VESD Electrostatic Discharge	Human Body Model(HBM)		±2000	V
	Charged Device Model(CDM)		±500	

Thermal Information

Parameter (Note 2)	Typ	Unit
θ_{JA} Junction-to-ambient Thermal Resistance	50	°C/W
θ_{JC} Junction-to-case Thermal Resistance	1	
P_D Power Dissipation $T_A=25^\circ\text{C}$	2	W

Recommended Operating Conditions

Parameter (Note 3)	Min	Max	Unit
VIN	1.9	5.5	V
VOUT	2.85	5.5	
Junction Temperature, Operating	-40	125	°C
Ambient Temperature	-40	85	

Electrical Characteristics

(VIN = 2.7V, VOUT=5.05V, schematic of Figure 1, TJ=-40°C to +85°C. Typical values are at TJ=25°C, unless otherwise specified. (Note 4))

Parameter	Symbol	Test Conditions	Min	Typ	Max	Unit
Input Voltage Range	VIN		1.9		5.5	V
Input UVLO Threshold	VUVLO			1.65	1.75	V
Input UVLO Hysteresis	VHYS			0.1		V
Output Voltage Range	VOUT		2.85		5.5	V
Quiescent Current	VIN (Boost)	ILOAD= 0A, VIN= VEN= 2.7V, VOUT=5.2V, Device not switching		3	5	µA
	VOUT (Boost)			28		µA
	VIN(Auto Bypass)	VEN=1.9V, VIN=5.2V		38	49	µA
	VIN(Forced Bypass)			21	29	µA
	VIN(low IQ Bypass)			16	22	µA
Shutdown Current	ISHDN	VEN=0V, VIN=5.2V		0.1		µA
EN Input Voltage High	VIH		0.9			V
EN Input Voltage Low	VIL				0.4	V
EN Leakage Current	IEN,LK	VEN=3.3V	-1		1	µA
Output Voltage Accuracy	VOUT_AC	ILOAD=1A, 0x02[5:0]='101100'	-1.5		1.5	%
Output Discharge Resistance	RDIS			75	110	Ω
Low Side Main FET RON	RDS(ON)1			17	30	mΩ
Synchronous FET RON	RDS(ON)2			17	28	mΩ
Bypass FET RON	RDS(ON)3			14	22	mΩ
Main FET Leakage Current	ILKG_LS	VEN=0V, VIN=VOUT=VSW=5.5V		0.1	1	µA
Synchronous FET Leakage Current	ILKG_HS	VEN=1.9V, VIN=2.7V, VOUT=5.5V, VSW=0V		0.1	1.5	µA
BYP FET Leakage Current	ILKG_BYP	VEN=0V, VIN=5.5V, VOUT=0V		0.1	2	µA

Parameter	Symbol	Test Conditions	Min	Typ	Max	Unit
Min ON Time	t _{ON,MIN}	(Note 5)		60		ns
Min OFF Time	t _{OFF,MIN}			160		ns
Switching Frequency	f _{SW}	I _{OUT} =1A	2	2.2	2.4	MHz
Boost Mode Valley Current Limit	I _{LMT,Valley}	0x03[3:0]='0011'(default)	4.2	5.5	6.8	A
Boost Mode Negative Current Limit	I _{LMT,Negative}			-2		A
Bypass Mode Current Limit	I _{LMT,BYP}	V _{IN} =5.2V		9		A
Input Over Voltage Threshold	V _{OV,IN}			5.8		V
Input Over Voltage Hysteresis	V _{OV,HYS}			0.3		V
Linear Charge Current Limit I	I _{CHARGE1}	V _{IN} -V _{OUT} > 300mV		1		A
Linear Charge Current Limit II	I _{CHARGE2}			2		A
Thermal Shutdown Temperature	T _{SD}			150		°C
Thermal Shutdown Hysteresis	T _{HYS}			20		°C
SCL, SDA Input Voltage High	V _{IH}		0.9			V
SCL, SDA Input Voltage Low	V _{IL}				0.4	V
SCL Clock Frequency	f _{SCL}		100		1000	kHz

Note 1: Stresses beyond the above “Absolute Maximum Ratings” may cause permanent damage to the device. These are stress ratings only. Functional operation of the device at these or any other conditions beyond those indicated in the operational sections of the specifications is not implied. Exposure to absolute maximum rating conditions for extended periods may affect device reliability.

Note 2: θ_{JA} is measured in the natural convection at T_A=25°C on a high effective thermal conductivity four-layer test board of JEDEC 51-3 thermal measurement standard.

Note 3: The device is not guaranteed to function outside its operating conditions.

Note 4: Unless otherwise stated, limits are 100% production tested under pulsed load conditions such that T_A ≅ T_J = 25°C. Limits over the operating temperature range (See recommended operating conditions) and relevant voltage range(s) are guaranteed by design, test, or statistical correlation.

Note 5: Guaranteed by design.

Typical Performance Characteristics

($T_A=25^\circ\text{C}$, $V_{IN}=2.7\text{V}$, $V_{OUT}=5.05\text{V}$; $L=0.47\mu\text{H}$, unless otherwise specified.)

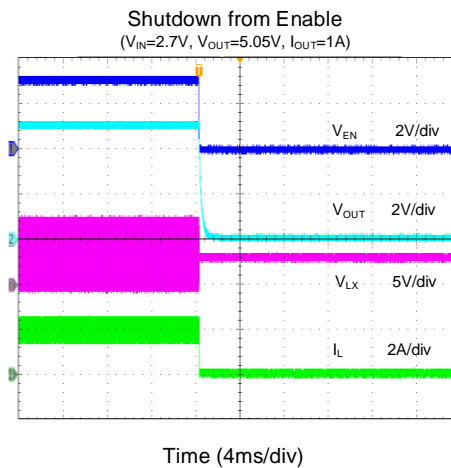
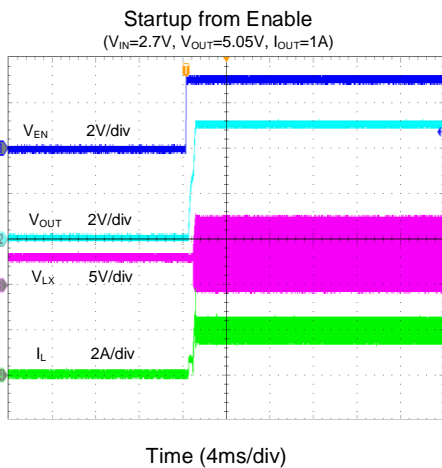
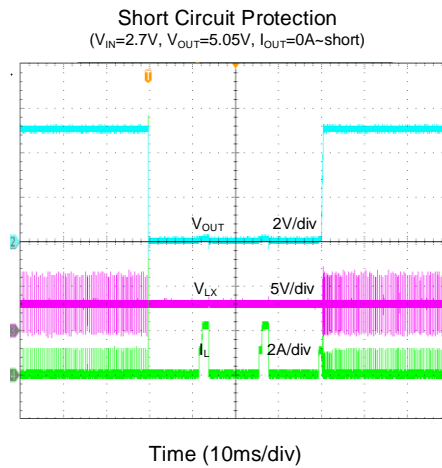
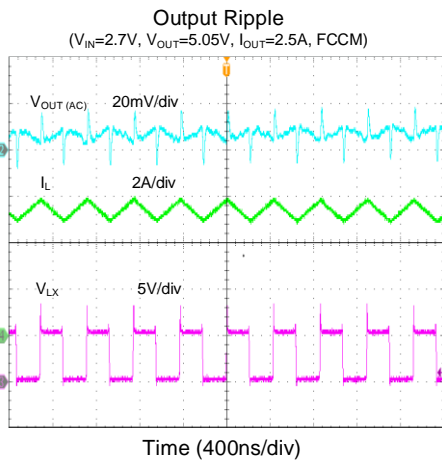
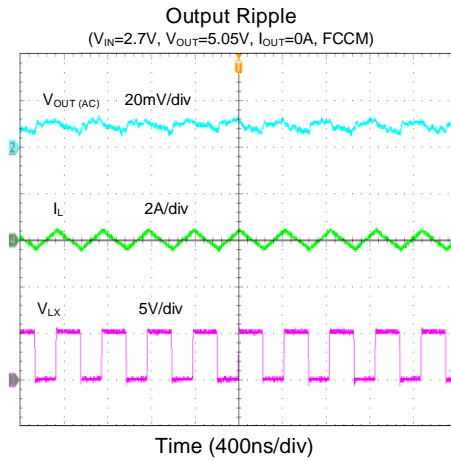
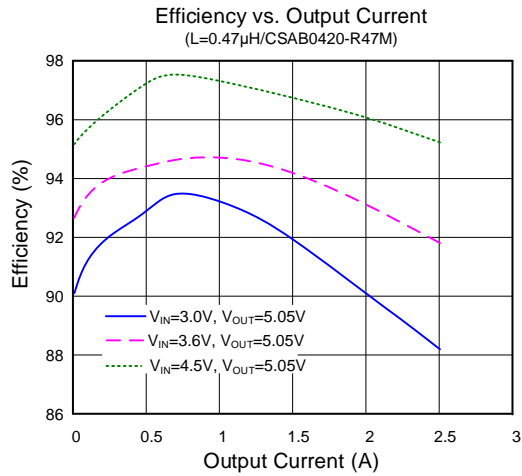

Applications Information

The SY87004A is a boost converter with adaptive constant on time control, which is designed for one-cell Li-Ion or LiFePO4 battery powered applications. It enters bypass mode when the battery is charged. The boost mode is automatically enabled when the battery voltage drops below the target voltage, so that the battery capacity can be fully utilized to provide power to blocks that require higher operating voltage.

The SY87004A operates over a wide input voltage range from 1.9V to 5.5V and integrates low $R_{DS(ON)}$ power MOSFETs.

Operating parameters including minimum output, current limit, operating mode can be configured using the I²C interface.

Input Capacitor C_{IN}

For the best performance, select a typical X5R or better grade ceramic capacitor. The component should be placed as close as possible to the VIN and PGND pins, while also minimizing the loop area formed by C_{IN} and the VIN/PGND pins. A 22μF low ESR ceramic capacitor is recommended for most applications.

Output Capacitor C_{OUT}

Both steady state ripple and transient requirements must be taken into account when selecting this capacitor. Using four X5R or better grade ceramic capacitors in parallel, with a 6.3V voltage rating and a capacitance higher than 10μF is recommended for most applications.

Boost Inductor L

There are several considerations in choosing this inductor.

- 1) Choose the inductance to provide the desired ripple current. It is suggested to choose the ripple current to be about 40% of the maximum average input current. The inductance is calculated as:

$$L = \left(\frac{V_{IN}}{V_{OUT}} \right)^2 \frac{(V_{OUT} - V_{IN})}{f_{SW} \times I_{OUT_MAX} \times 40\%}$$

Where f_{SW} is the switching frequency and I_{OUT_MAX} is the maximum load current.

The SY87004A is tolerant to different ripple current amplitudes. Consequently, the final choice of the inductance can be slightly different than the calculated value without significantly impacting the performance.

- 2) The saturation current rating of the inductor must be selected to be greater than the peak inductor current under full load conditions.

$$I_{SAT_MIN} > \left(\frac{V_{OUT}}{V_{IN} \times \eta} \right) \times I_{OUT_MAX} + \frac{V_{IN}(V_{OUT} - V_{IN})}{2 \times f_{SW} \times L \times V_{OUT}}$$

- 3) The DCR of the inductor and the core loss at the switching frequency must be low enough to achieve the desired efficiency requirement. It is desirable to choose an inductor with $DCR < 30m\Omega$ to achieve a good overall efficiency.

Enable Operation

The EN pin controls SY87004A start up. The EN pin low to high transition starts the power up sequence. If the EN pin is low, the DC/DC converter will be turned off.

When EN is high, the SY87004A allows software to enable the regulator, through the DEV_EN bit.

Hardware and Software Enable control table as follows:

EN PIN	DEV_EN (0x01[6])	OUTPUT
0	x	OFF
1	0	OFF
1	1	ON

Discharge Operation

The VOUT_DISCHG bit allows SY87004A to discharge output voltage through an internal pull-down resistor. The control strategy is as follows:

VOUT_DISCHG (0x01[3])	EN PIN	DEV_EN (0x01[6])	STATUS
1	L	x	Discharge
	H	0	Discharge
0	L	x	Discharge
	H	0	No discharge

The discharge circuit is enabled when an output overvoltage condition is detected. The overvoltage threshold is 120% the target output voltage.

Start Up Operation

When $V_{IN} > UVLO$ and EN transitions from low to high, the SY87004A initiates the startup sequence where the output voltage gradually ramps until $V_{OUT} > 0.9 \times V_{IN}$. The linear startup period includes two different states: LIN1 and LIN2. During LIN1, the current limit is set to 1A for a 800μs duration. If V_{OUT} is still lower than $0.9 \times V_{IN}$ after this duration, the converter enters LIN2 state where 2A current limit is used for 1600μs. If V_{OUT} is still lower than $0.9 \times V_{IN}$ after the

LIN2 duration, the device enters fault mode. Otherwise, it will enter soft-start operation to reach the V_{OUT} setting. During the soft-start state, if the target V_{OUT} is not reached in 2ms, the device also enters fault mode.

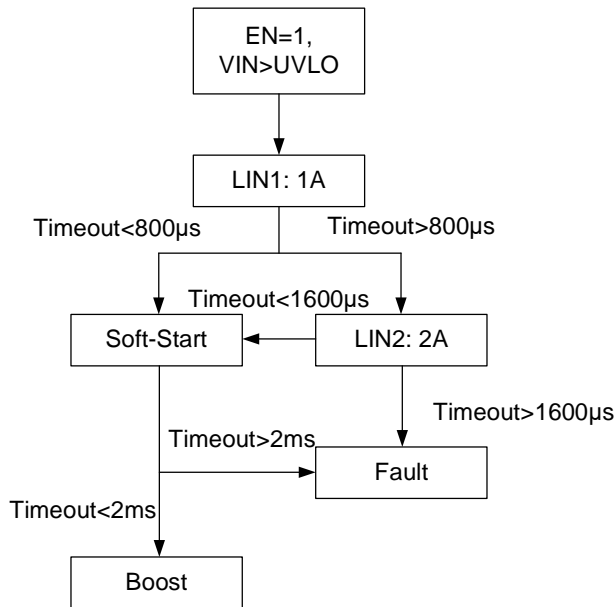

Figure4. Start Up Operation

Spread Spectrum Function

The spread spectrum function is enabled by 0x01[1] to optimize EMI performance. The operating frequency is varied $\pm 15\%$ centered on frequency. The modulation signal is a triangular wave with a period of $100\mu s$. When spread spectrum is enabled, fsw ramps down 15% and back to the center frequency in $50\mu s$, followed by a ramp up 15% and back to the center frequency in $50\mu s$.

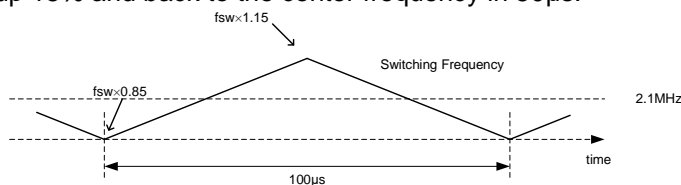

Figure5. Spread Spectrum

Eliminating the 10kHz ripple caused by the spread spectrum can be obtained by enabling a ripple cancellation feature by writing to setting bit [2] at register address 0x01.

Forced Bypass Operation

The SY87004A can operate in forced bypass mode, which can be enabled programming bits [5:4] at register address 0x01. In forced bypass mode, the output is connected to input directly, while the quiescent current is reduced.

Light Load Operation

The SY87004A can operate in burst mode during light load conditions to maintain high-efficiency. PFM operation is automatically initiated when the inductor current falls to zero. As the load decreases further the resulting switching frequency will also decrease in order to keep the output close to the target value.

Overcurrent Protection

The SY87004A provides cycle by cycle overcurrent protection and turns off the power MOSFET once the inductor valley current reaches the current setting limit configured by bits [3:0] at register address 0x03. Fault events can be detected by reading the fault flag, located at bit[1] register address 0x04.

Input Overvoltage Protection

The SY87004A includes input over voltage protection. If the input voltage exceeds $V_{OVP,IN}$ (typ. 5.8V), the device will stop switching, and trigger a fault flag. When the input voltage returns to the normal operating range, the device resumes operation.

Output Undervoltage Protection

The SY87004A includes output under voltage protection. If the output voltage drops below 88% of input voltage, the device will shutdown and trigger a fault flag.

Thermal Protection

The SY87004A includes over temperature protection circuitry to prevent overheating due to excessive power dissipation. This will shut down the device when the junction temperature exceeds $150^{\circ}C$. Once the junction temperature cools down by approximately $20^{\circ}C$, the device will resume normal operation after a complete soft-start cycle. For continuous operation, provide adequate cooling so that the junction temperature does not exceed the thermal protection threshold.

I²C Interface

Peripheral Address List

State	V _{ADDR}	Peripheral Address
1	LOW	1110101x
2	HIGH	1110110x
3	FLOAT	1110111x

Register Memory Map

Name	Address	Description
DEVICE ID	0x00	Device ID information
CONFIG	0x01	Set several configures
VOUT	0x02	Set output voltage.
ILIMSET	0x03	Set input current valley limit and soft-start current limit.
STATUS	0x04	Device status.

The SY87004A features an I²C interface that allow a host processor to configure the operation and control the output voltage. The I²C interface supports clock speeds of up to 1MHz and uses standard I²C commands. The SY87004A always operates as a peripheral device, and it is addressed using a 7-bit slave address followed by an 8th bit, which indicates whether the transaction is a read-operation or a write-operation.

START and STOP Conditions:

The SY87004A is controlled via an I²C compatible interface. The START condition is a HIGH to LOW transition of the SDA line while SCL is HIGH. The STOP condition is a LOW to HIGH transition on the SDA line while SCL is HIGH. A STOP condition must be sent before each START condition. The I²C controller always generates the START and STOP conditions.

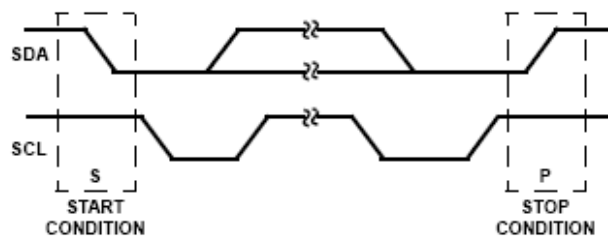

Data Validity:

The data on the SDA line must be stable during the HIGH period of the SCL, unless generating a START or STOP condition. The HIGH or LOW state of the data line can only change when the clock signal on the SCL line is LOW.

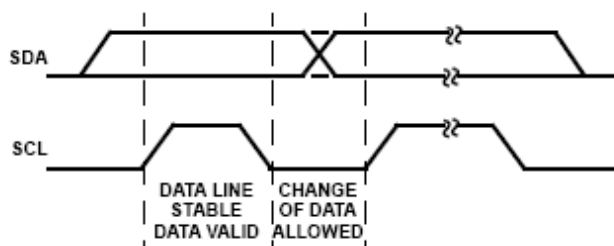

Acknowledge:

Each address and data transmission byte uses 9-clock pulses. The ninth pulse is the acknowledge bit (ACK). After the START condition, the controller sends 7-slave address bits and an R/W bit during the next 8-clock pulses. During the ninth clock pulse, the device that recognizes its own address holds the data line low to acknowledge. The acknowledge bit is also used by both the controller and the peripheral to acknowledge receipt of register addresses and data.

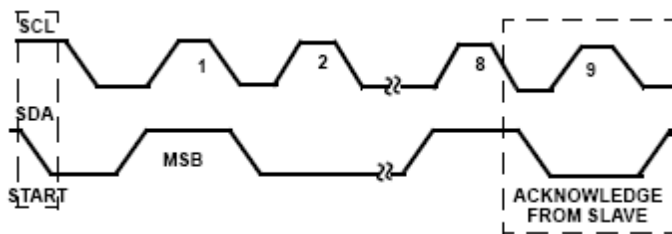

Data Transactions:

All transactions start with a control byte sent from the I²C controller device. The control byte begins with a START condition, followed by 7-bits of slave address (1110101x) for the SY87004A (this address can be set by R_{ADDR}), followed by the 8th bit, R/W bit. The R/W bit is 0 for a write or 1 for a read. If any peripheral devices on the I²C bus recognize their address, they will acknowledge by pulling the SDA line low for the last clock cycle in the control byte. If no peripheral exists at that address or are not ready to communicate, the data line will be 1, indicating a Not Acknowledge condition. Once the control byte is sent, and the SY87004A acknowledges it, the 2nd byte sent by the controller must be a register address byte. The register address byte tells the SY87004A which register the master will write to or read from. Once the SY87004A receives the register address byte, it responds with an acknowledge.

Write To A Register



Read From A Register

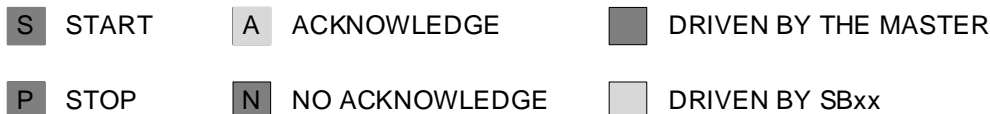

Register Settings

1. DEVICE ID (0x00) , the default value is 0x11.

Register Name	Bit	R/W	Default	Description
Manufacturer	7:4	R	0001	Device identity
DEV_VER	3:0	R	0001	Device version

2. CONFIG (0x01) , the default value is 0x68.

Register Name	Bit	R/W	Default	Description
RESET	7	R/W	0	Device reset bit. 0: Keep current register setting. 1: Reset to default register value. This bit returns to 0 after register reset is completed. The device operation is cycled (ON-OFF-ON), which means the converter is disabled for a short time and restarts with default parameters.
DEV_EN	6	R/W	1	Device enable bits. 0: Disable the device. 1: Device Enable.
AUTO_BYPASS	5:4	R/W	10	Device auto bypass bit. 00: Device operates in forced bypass mode with low iq. 01: Device operates in forced bypass mode (Only bypass mode). 10~11: Device operates in auto bypass mode (Auto transition between DC/DC boost and bypass).
VOUT_DISCHG	3	R/W	1	Output discharge control bit. 0: When the regulator is disabled, VOUT is not discharged. 1: When the regulator is enabled, VOUT discharges through an internal pull-down resistor.
SSFM_COMP	2	R/W	0	Spread spectrum ripple cancellation control bit. 0: Disable SSFM ripple cancellation. 1: Enable SSFM ripple cancellation.
SSFM	1	R/W	0	Spread spectrum control bit. 0: Spread spectrum modulation is disabled. 1: Spread spectrum modulation is enabled in PWM mode.
MODE_CTRL	0	R/W	0	Light load mode 0: PFM with automatic transition into PWM operation. 1: Forced PWM operation.

3. VOUT (0x02), the default value is 0xEC.

Register Name	Bit	R/W	Default	Description
VC_GM	7:6	R/W	11	00: 6uS; 01:12uS; 10:18uS; 11:24uS
VOUT	5:0	R/W	101100	Output voltage setting, DC/DC boost/bypass mode change. It has an offset of 2.85V and a range from 2.85V to 5.5V with 50mV voltage step for VOUT. It is set to 5.05V by default. 000000: 2.850V 000001: 2.900V 000010: 2.950V 001011: 3.400V 101100: 5.050V(Default) 110100: 5.450V 110101~111111: 5.500V

4. ILIMSET (0x03), the default value is 0x13.

Register Name	Bit	R/W	Default	Description
RESERVED	7	R/W	0	Always reads back 0
BYPASS_WAY	6	R/W	0	Bypass path selection bit. 0: Only the Bypass switch opens. 1: The Bypass and High side MOSFETs open together.
ILIM_OFF	5	R/W	0	Enable/Disable Valley Inductor Current Limit in DC/DC boost mode. 0: Current Limit Enabled 1: Current Limit Disabled
SOFT-START	4	R/W	1	Soft-start current limit selection bit. 0: Boost soft-start current is limited according to ILIM bit settings 1: Boost soft-start current is limited to 2A inductor valley current
ILIM	3:0	R/W	0011	Inductor valley current limit in DC/DC boost mode. 0000: 4A 0001: 4.5A 0010: 5A 0011: 5.5A(Default) 0100: 6A 0101: 6.5A 0110: 7A 0111: 7.5A 1000: 8A 1001: 8.5A 1010~1111: 9A

5. STATUS (0x04), the default value is 0x00.

Register Name	Bit	R/W	Default	Description
TSD	7	R	0	0: Normal operation. 1: Thermal shutdown triggered. This flag is reset after readout.
RESERVED	6	R	0	Always reads back 0
DCDCMODE	5	R	0	Real-time detection the working states. 0: Device operates in PWM mode. 1: Device operates in PFM mode.
OPMODE	4	R	0	Real-time detection the operation mode. 0: Device operates in bypass mode. 1: Device operates in DC/DC mode.
ILIM_BYP	3	R	0	0: Normal operation. 1: Indicates that the bypass FET current limit has triggered in bypass mode. This flag is reset after readout.
ILIM_BST	2	R	0	0: Normal operation. 1: Indicates that the valley inductor current limit has triggered in DC/DC boost mode. This flag is reset after readout.
FAULT	1	R	0	0: Normal operation. 1: Indicates that a fault condition has occurred, including OTP, OCP, start-up fail, UVP and VIN OVP function This flag is reset after readout.
PGOOD	0	R	0	0: Indicates the output voltage is out of regulation. 1: Indicates the output voltage is within its nominal range. This bit is set if the converter is forced in bypass mode.

Schematic

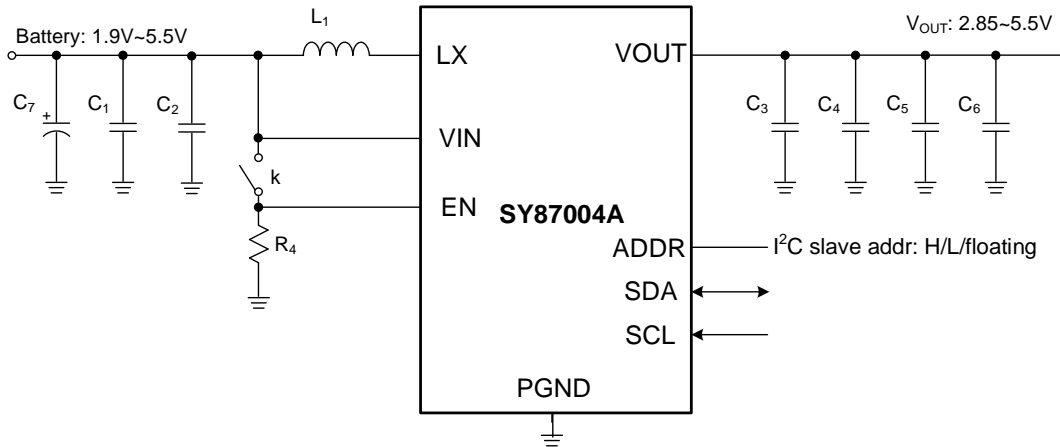

BOM List

Designator	Description	Part Number	Manufacturer
U ₁		SY87004AWUS	Silergy
C ₁	22μF/10V/X7S,1206	C3216X7S1A226MTJ00E	TDK
C ₂	0.1μF/25V/X7R,0603	CGA3E2X7R1E104KT0Y0N	TDK
C _{3, C4, C5, C6}	10μF/6.3V/X7R,1206	C3216X7R0J106K085AB	TDK
C ₇	100μF/25V/Electrolytic Capacitor		
L ₁	0.47μH	CSAB0420-R47M	CODACA
R ₄	1M,1%,0603		

Layout Design

The layout design of SY87004A regulator is highly simplified. To achieve a higher efficiency and better noise immunity, following components should be placed close to the IC: C_{IN}, C_{OUT}, L.

- 1) It is desirable to maximize the PCB copper area connecting to PGND pin to achieve the best thermal and noise performance. If the board space allowed, a ground plane is highly desirable.
- 2) C_{IN} must be close to Pins VIN and PGND. The loop area formed by C_{IN} and GND must be minimized.
- 3) The PCB copper area associated with LX pin must be minimized to avoid the potential noise problem.
- 4) If the system chip interfacing with the EN pin has a high impedance state at shutdown mode and the VIN pin is connected directly to a power source such as a Li-Ion battery, it is desirable to add a pull down 1MΩ resistor between the EN and PGND pins to prevent the noise from falsely turning on the regulator at shutdown mode.

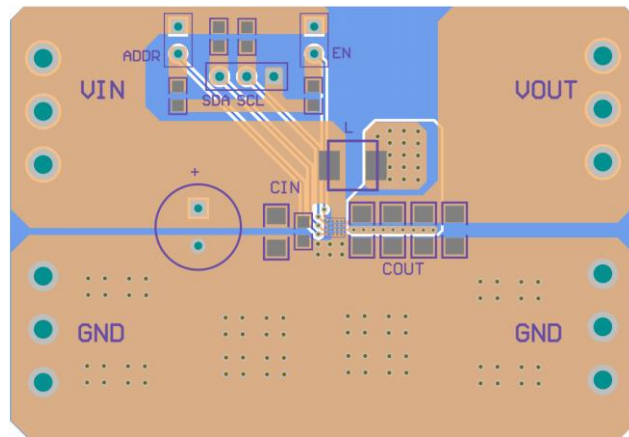
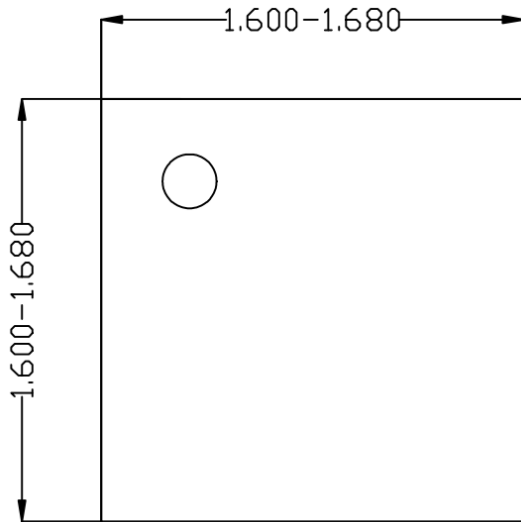
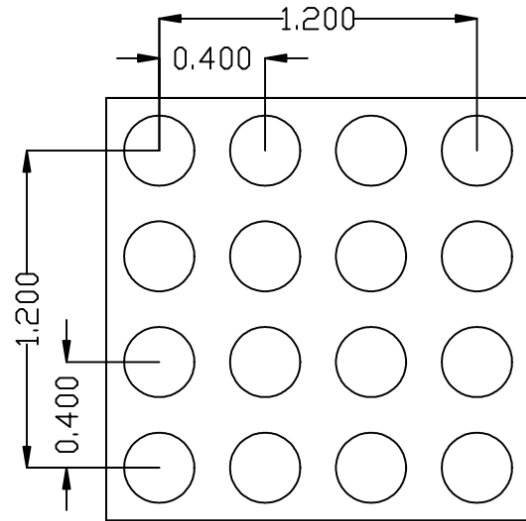

Figure 6. PCB Layout Suggestion

CSP1.65x1.65-16 Package Outline Drawing



Top View



Bottom View

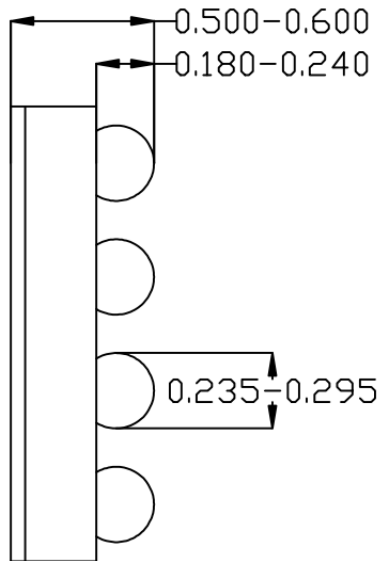

Side View

Notes: All dimension in millimeter and exclude mold flash & metal burr.



Revision History

The revision history provided is for informational purposes only and is believed to be accurate; however, not warranted. Please make sure that you have the latest revision.

Date	Revision	Change
Mar.16, 2026	Revision 1.0	Initial Release



IMPORTANT NOTICE

- 1. Right to make changes.** Silergy and its subsidiaries (hereafter Silergy) reserve the right to change any information published in this document, including but not limited to circuitry, specification and/or product design, manufacturing or descriptions, at any time and without notice. This document supersedes and replaces all information supplied prior to the publication hereof. Buyers should obtain the latest relevant information before placing orders and should verify that such information is current and complete. All semiconductor products are sold subject to Silergy's standard terms and conditions of sale.
- 2. Applications.** Application examples that are described herein for any of these products are for illustrative purposes only. Silergy makes no representation or warranty that such applications will be suitable for the specified use without further testing or modification. Buyers are responsible for the design and operation of their applications and products using Silergy products. Silergy or its subsidiaries assume no liability for any application assistance or designs of customer products. It is customer's sole responsibility to determine whether the Silergy product is suitable and fit for the customer's applications and products planned. To minimize the risks associated with customer's products and applications, customer should provide adequate design and operating safeguards. Customer represents and agrees that it has all the necessary expertise to create and implement safeguards which anticipate dangerous consequences of failures, monitor failures and their consequences, lessen the likelihood of failures that might cause harm and take appropriate remedial actions. Silergy assumes no liability related to any default, damage, costs or problem in the customer's applications or products, or the application or use by customer's third-party buyers. Customer will fully indemnify Silergy, its subsidiaries, and their representatives against any damages arising out of the use of any Silergy components in safety-critical applications. It is also buyers' sole responsibility to warrant and guarantee that any intellectual property rights of a third party are not infringed upon when integrating Silergy products into any application. Silergy assumes no responsibility for any said applications or for any use of any circuitry other than circuitry entirely embodied in a Silergy product.
- 3. Limited warranty and liability.** Information furnished by Silergy in this document is believed to be accurate and reliable. However, Silergy makes no representation or warranty, expressed or implied, as to the accuracy or completeness of such information and shall have no liability for the consequences of use of such information. In no event shall Silergy be liable for any indirect, incidental, punitive, special or consequential damages, including but not limited to lost profits, lost savings, business interruption, costs related to the removal or replacement of any products or rework charges, whether or not such damages are based on tort or negligence, warranty, breach of contract or any other legal theory. Notwithstanding any damages that customer might incur for any reason whatsoever, Silergy' aggregate and cumulative liability towards customer for the products described herein shall be limited in accordance with the Standard Terms and Conditions of Sale of Silergy.
- 4. Suitability for use.** Customer acknowledges and agrees that it is solely responsible for compliance with all legal, regulatory and safety-related requirements concerning its products, and any use of Silergy components in its applications, notwithstanding any applications-related information or support that may be provided by Silergy. Silergy products are not designed, authorized or warranted to be suitable for use in life support, life-critical or safety-critical systems or equipment, nor in applications where failure or malfunction of a Silergy product can reasonably be expected to result in personal injury, death or severe property or environmental damage. Silergy assumes no liability for inclusion and/or use of Silergy products in such equipment or applications and therefore such inclusion and/or use is at the customer's own risk.
- 5. Terms and conditions of commercial sale.** Silergy products are sold subject to the standard terms and conditions of commercial sale, as published at <http://www.silergy.com/stdterms>, unless otherwise agreed in a valid written individual agreement specifically agreed to in writing by an authorized officer of Silergy. In case an individual agreement is concluded only the terms and conditions of the respective agreement shall apply. Silergy hereby expressly objects to and denies the application of any customer's general terms and conditions with regard to the purchase of Silergy products by the customer.
- 6. No offer to sell or license.** Nothing in this document may be interpreted or construed as an offer to sell products that is open for acceptance or the grant, conveyance or implication of any license under any copyrights, patents or other industrial or intellectual property rights. Silergy makes no representation or warranty that any license, either express or implied, is granted under any patent right, copyright, mask work right, or other intellectual property right. Information published by Silergy regarding third-party products or services does not constitute a license to use such products or services or a warranty or endorsement thereof. Use of such information may require a license from a third party under the patents or other intellectual property of the third party, or a license from Silergy under the patents or other intellectual property of Silergy.

For more information, please visit: www.silergy.com

©2026 Silergy Corp.

All Rights Reserved.