

General Description

SY22791A is a single-stage Boost PFC driver for LED lighting applications. Good compatibility is achieved with Leading/Trailing edge dimmer and high PF is achieved without any dimmer.

SY22791A drives the converter in Quasi-Resonant mode to achieve high efficiency. Reliable Open LED protections are integrated.

SY22791A integrates high voltage power FET inside to save driver space further.

SY22791A is available in SOT23-5 package.

Ordering Information

SY22791 □(□□)□
 └───┬───┬───
 Temperature Code
 Package Code
 Optional Spec Code

Ordering Number	Package type	Note
SY22791AAAC	SOT23-5	----

Features

- Compatible with Leading Edge/Trailing Edge Dimmer
- High PF without Any Dimmer
- 500V MOSFET Integrated
- Quasi-Resonant Operation
- Reliable Open LED Protection
- Thermal Fold Back
- Low BOM Cost
- RoHS Compliant and Halogen Free
- Compact Package: SOT23-5

Applications

- LED Lighting
- Leading Edge Dimming
- Trailing Edge Dimming

Typical Applications

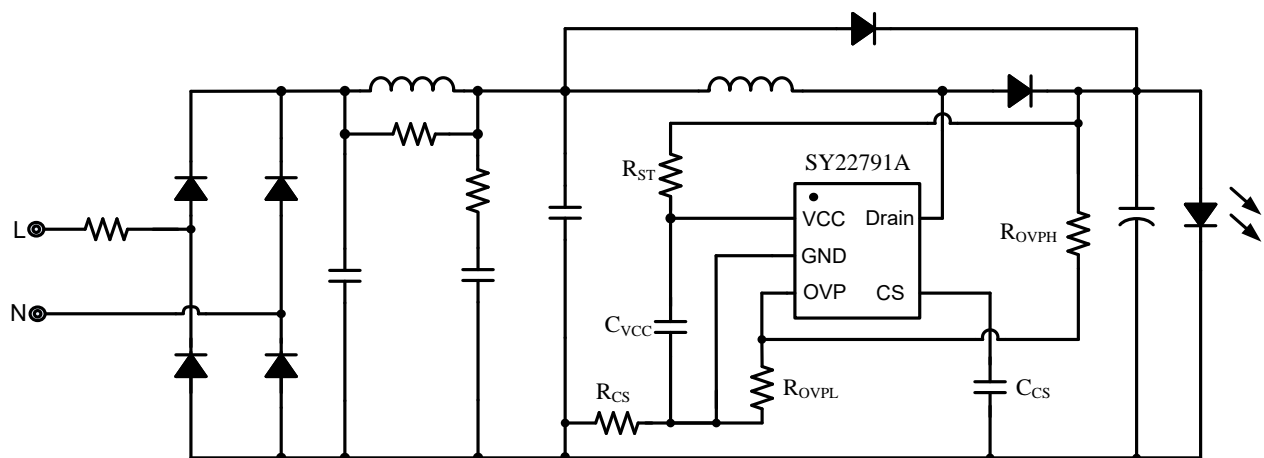
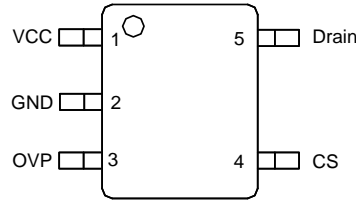

Figure 1. Typical application

Pinout (top view)



(SOT23-5)

Top Mark: dY.xyz (device code: dY, x=year code, y=week code, z=lot number code)

Pin Name	PIN Number	Pin Description
VCC	1	Bias supply pin.
GND	2	Ground pin.
OVP	3	Voltage sense pin. Connect to a resistor divider of inductor or auxiliary winding to sense output voltage. $V_{OVP} = K \times V_{OVP,REF}$, where K is the OVP resistor ratio coefficient.
CS	4	Current sense pin, connect a cap and sense res to GND pin. $R_{CS} = \frac{V_{REF}}{2I_O}$
Drain	5	Internal MOSFET drain node.

Block Diagram

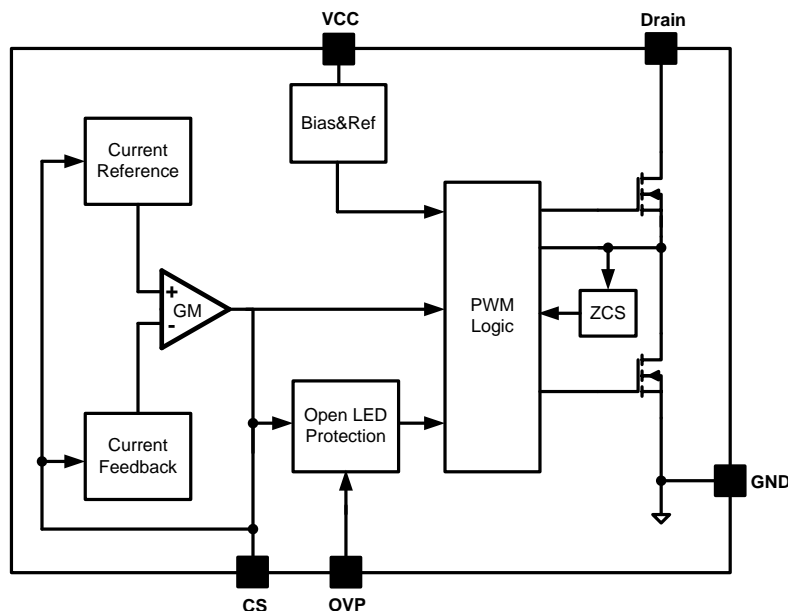

Fig.2 Simplified block diagram



Absolute Maximum Ratings (Note 1)

VCC	-----	-0.3V~20V
I _{VCC}	-----	4mA
CS, OVP	-----	-0.3V~3.6V
Drain	-----	500V
Power Dissipation, @ TA = 25°C SOT23-5	-----	0.6W
Package Thermal Resistance (Note 2)		
SOT23-5, θ_{JA}	-----	170°C/W
SOT23-5, θ_{JC}	-----	130°C/W
Maximum Junction Temperature	-----	160°C
Lead Temperature (Soldering, 10 sec.)	-----	260°C
Storage Temperature Range	-----	-65°C to 160°C

Electrical Characteristics

($V_{VCC} = 12V$ (Note 3), $T_A = 25^\circ C$ unless otherwise specified)

Parameter	Symbol	Test Conditions	Min	Typ	Max	Unit
Power Supply Section						
VCC Turn-on Threshold	V_{VCC_ON}		13.1	14.1	15.0	V
VCC Turn-off Threshold	V_{VCC_OFF}		6.8	7.4	8.0	V
VCC Shunt Voltage	V_{VCC_Shunt}	$I_{VCC}=1mA$	13.5	14.5	15.5	V
Start up Current	I_{ST}		33	43	54	μA
Quiescent Current	I_Q		192	231	270	μA
CS Pin Section						
Current Reference	V_{REF}		216	223	230	mV
CS Limit	V_{CS_MAX}		1.35	1.42	1.5	V
OVP Pin Section						
OVP Voltage Reference	V_{OVP_REF}		1.15	1.2	1.3	V
Driver Section						
Min ON Time	T_{ON_MIN}			550		ns
Max ON Time	T_{ON_MAX}			10.5		μs
Min OFF Time	T_{OFF_MIN}			1.5		μs
Max OFF Time	T_{OFF_MAX}			260		μs
Integrated MOSFET Section						
BV of HV MOSFET	V_{BV}		500			V
HV MOS Drain Source Resistance	R_{DSON_H}			8	10	Ω
Thermal Section						
Thermal Fold Back Temperature	T_{FB}			155		$^\circ C$
Thermal Shut Down Temperature	T_{SD}			$T_{FB} + 5$		$^\circ C$

Note 1: Stresses beyond the “Absolute Maximum Ratings” may cause permanent damage to the device. These are stress ratings only. Functional operation of the device at these or any other conditions beyond those indicated in the operational sections of the specification is not implied. Exposure to absolute maximum rating conditions for extended periods may affect device reliability.

Note 2: θ_{JA} is measured in the natural convection at $T_A = 25^\circ C$ on a low effective single layer thermal conductivity test board of JEDEC 51-3 thermal measurement standard. Test condition: Device mounted on 2” x 2” FR-4 substrate PCB, 2oz copper, with minimum recommended pad on top layer and thermal vias to bottom layer ground plane.

Note 3: Increase VCC pin voltage gradually higher than V_{VCC_ON} voltage then turn down to 12V.

Operation

SY22791A is a single stage Boost PFC regulator targeting at LED lighting applications.

It is mainly used in mains dimming application and has good compatibility with Leading/Trailing edge dimmer.

In order to reduce the switching losses and improve EMI performance, Quasi-Resonant switching mode is applied, which means to turn on the power MOSFET at the valley of drain voltage.

It also provides reliable open LED protections and over temperature protection.

The IC is available with SOT23-5 package.

Applications Information

Start up

After AC supply is powered on, the capacitor C_{VCC} between VCC and GND pin is charged up by output voltage (peak value of input voltage at the first of power on). Once V_{VCC} rises up to V_{VCC_ON} , the internal blocks start to work.

The whole start up procedure is divided into three sections as shown below. t_{ST1} is the C_{VCC} charged up time until V_{VCC} reaches V_{VCC_ON} . t_{ST2} is the time V_{VCC} rises to V_{VCC_shunt} , then a shunt current works to guarantee VCC at a stable value. t_{ST3} is the time IC works at steady state. Usually t_{ST2} is much smaller than t_{ST1} .

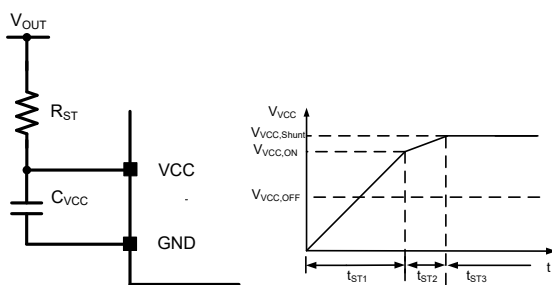

Fig.3 Start up

The start up component R_{ST} and C_{VCC} are designed as below:

(a) Set start-up resistor R_{ST} , make sure that the operation current is enough through R_{ST} . The worst case occurs at minimum input voltage, because after start up, the bias supply current is from V_{OUT} which is higher than peak value of input voltage.

$$R_{ST} < \frac{\sqrt{2}V_{AC,MIN}}{I_Q}$$

Where $V_{AC,MIN}$ is the RMS value of minimum AC input voltage, I_Q is the operation current.

(b) Select C_{VCC} to obtain an ideal start up time t_{ST} . The recommended formula is as below:

$$C_{VCC} = \frac{(\frac{\sqrt{2}V_{AC,MIN}}{R_{ST}} - I_{ST}) \times t_{ST}}{V_{VCC_ON}}$$

Where I_{ST} is the start up current. V_{VCC_ON} is the start up voltage of internal circuit.

Shut down

After AC supply is powered off, the energy stored in the output capacitor is discharged. When power supply for IC is not enough, V_{VCC} drops down. Once V_{VCC} is below V_{VCC_OFF} , the IC stops working.

LED current setting

LED current is set by the resistor R_{CS} . The formula to program I_{LED} is as below:

$$I_{LED} = \frac{V_{REF}}{2 \times R_{CS} \times k}$$

Where V_{REF} is the reference voltage, R_{CS} set the LED current, and k is a coefficient. k varies slightly in different application and typical value of k is 1.15.

Open LED protection

The protection voltage V_{OVP} for open LED is set by the resistor divider shown as below,

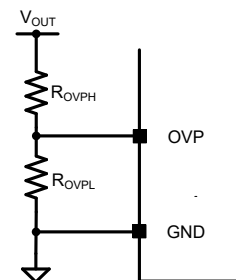

Fig.4 OVP set

Then V_{OVP} is set by the formula,

$$V_{OVP} = \frac{R_{OVPH} + R_{OVPL}}{R_{OVPL}} V_{OVP,REF}$$

Where $V_{OVP,REF}$ is 1.2V. When OVP triggers, Switching stops and VCC is pulled down until V_{VCC_OFF} , then IC starts up again and works in hiccup mode.

Thermal protection

Thermal fold back is adopted in this IC. Thermal fold back curve is shown as below.

When the junction temperature rises too high, internal current reference decreases first; if the junction temperature still rises up over T_{SD} , IC will be shut down.

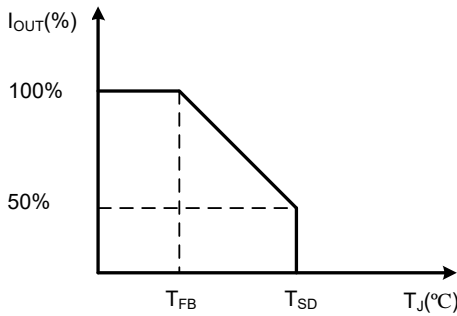

Fig.5 Thermal fold back curve

Power Device Design

MOSFET and Diode

When the operation condition is with maximum output voltage, the voltage stress of MOSFET and output power diode is maximized. MOSFET is integrated with 500V BV.

$$V_{DS_MAX} = V_{OUT,MAX}$$

Inductor (L)

The system operates in the peak current mode. The ON time increases with the input voltage decreasing. When the ON time reaches T_{ON_MAX} , the ON time is limit by T_{ON_MAX} .

The input voltage and inductor current waveforms are shown as below, where θ_1 and θ_2 are the first time and last time that inductor current touches the limit in each half line cycle. V_{IN1} is the instantaneous value of input voltage at θ_1 and θ_2 .

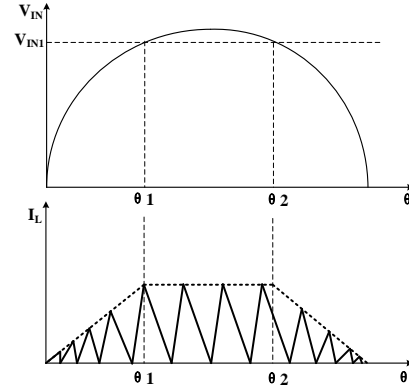

Fig.6 Input and output waveforms

In Quasi-Resonant mode, each switching period t_s consists of three parts: inductor current rising time t_1 , falling time t_2 and quasi-resonant time t_3 .

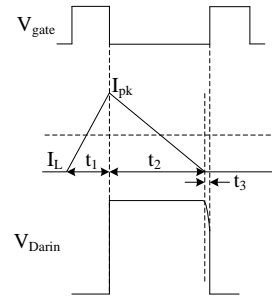

Fig.8 switching waveforms

The switching frequency is designed in rated input voltage considering conducted EMI test. Once the switching frequency f_{sw} is set, the inductance of the inductor could be calculated.

The design flow is shown as below:

(a) Preset frequency f_{sw} at peak value of rated input voltage

(b) Compute relative t_s , t_1 (ignore t_3)

$$t_s = \frac{1}{f_{sw}}$$

$$t_1 = \frac{t_s \times (V_{OUT} - \sqrt{2}V_{AC_RMS})}{V_{OUT}}$$

$$t_2 = t_s - t_1$$

Where V_{AC_RMS} is the RMS value of rated input voltage.

(c) Compute the peak current of inductor I_{PK} .

$$V_{IN1} = \sqrt{2}V_{AC_RMS} \frac{t_1}{t_{ON_MAX}}$$

$$\theta_1 = \arcsin\left(\frac{V_{IN1}}{\sqrt{2}V_{AC_RMS}}\right)$$

$$I_{PK} \approx \frac{I_{OUT} \cdot V_{OUT} \cdot \pi}{\sqrt{2}V_{AC_RMS} \cdot \cos\left(\frac{\theta_1}{2}\right)}$$

Where V_{OUT} is the rated output voltage, I_{OUT} is rated output current. t_{ON_MAX} is maximum conducting time.

(d) Design inductance L

$$L = \frac{\sqrt{2}V_{AC_RMS} \times t_1}{I_{PK}}$$

Inductor design (N)

Necessary parameters:	
Inductance	L
Io program resistor	R_{CS}
Current low limit voltage	V_{CS_MIN}
Current high limit voltage	V_{CS_MAX}

V_{CS_MIN} is 500mV, The design rules are as followed:

(a) Select the magnetic core type, identify the effective area A_e .

(b) Preset the maximum magnetic flux ΔB .
For PC40, ΔB selected to be 0.3~0.33T.

(c) Compute inductor maximum peak current $I_{L_PK_MAX}$ and maximum RMS current $I_{L_RMS_MAX}$.

$$I_{L_PK_MAX} = \frac{V_{CS_MAX} - V_{CS_MIN}}{R_{CS}}$$

$$I_{L_RMS_MAX} = \frac{1}{\sqrt{3}} I_{L_PK_MAX}$$

(d) Compute turn N

$$N = \frac{L}{\Delta B \times A_e} \times I_{L_PK_MAX}$$

(e) Select an appropriate wire diameter with $I_{L_RMS_MAX}$, select appropriate wire to make sure the current density ranges from 4A/mm² to 10A/mm².

(f) If the winding area of the core and bobbin is not enough, reselect the core style, go to (a) and redesign the inductor until the ideal inductor is achieved.

Output capacitor C_{OUT}

Choose proper output capacitance to satisfy current ripple. Output current ripple is set to ΔI_O , then,

$$C_{OUT} = \frac{\sqrt{\left(\frac{2I_{OUT}}{\Delta I_O}\right)^2 - 1}}{4\pi \times R_{LED} \times f_{AC}}$$

Where f_{AC} is the AC supply frequency; R_{LED} is the equivalent series resistor of LED load.

SOT23-5 Package outline & PCB layout design

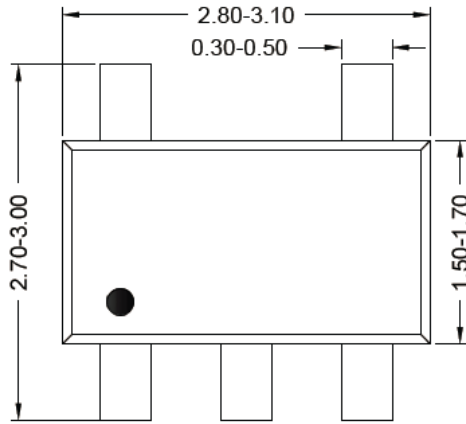

Top view

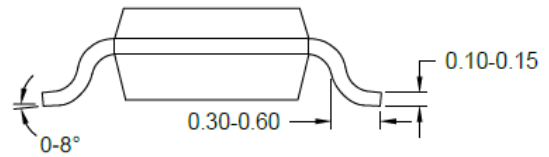

Side view

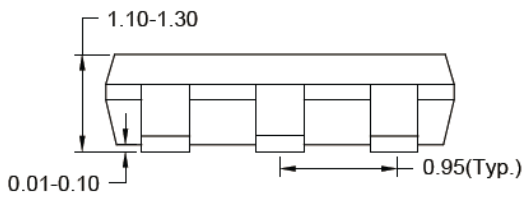

Front view

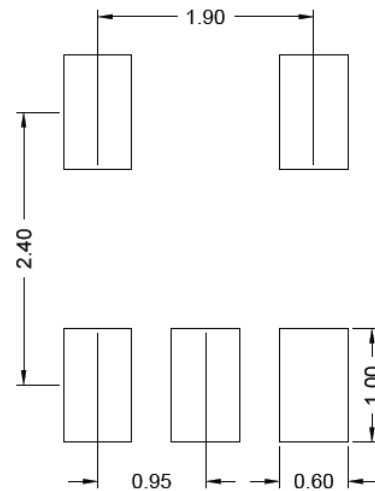

Recommended Pad Layout

Notes: All dimension in millimeter and exclude mold flash & metal burr.

Taping & Reel Specification

1. Taping orientation for packages (SOT23-5)

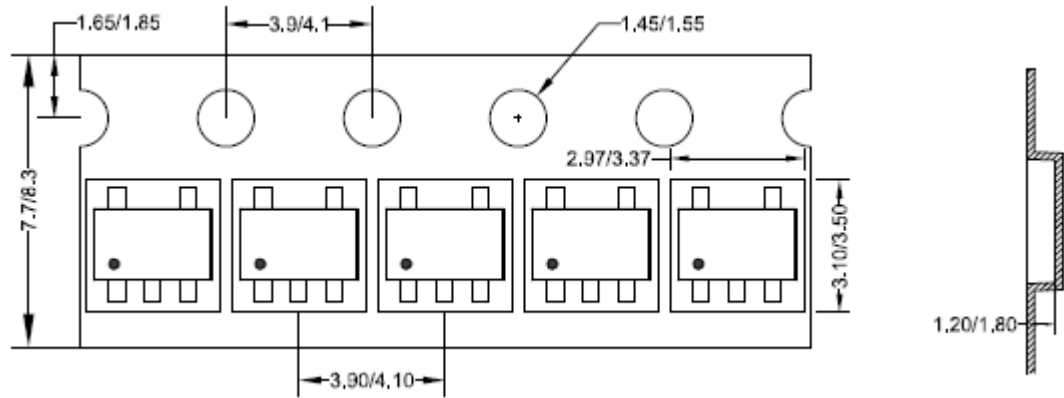

Feeding direction →

2. Carrier Tape & Reel specification for packages

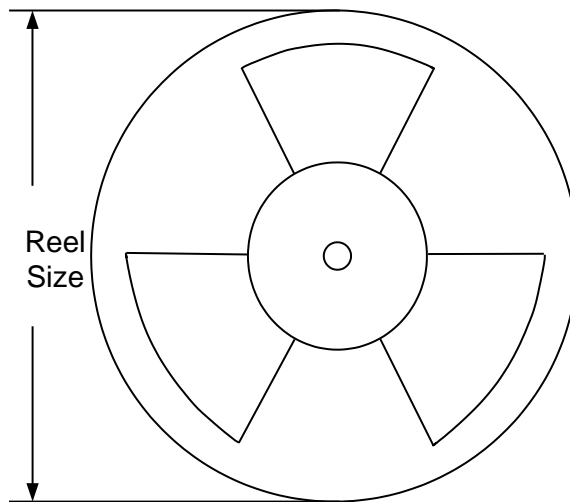

Package type	Tape width (mm)	Pocket pitch(mm)	Reel size (Inch)	Trailer length(mm)	Leader length (mm)	Qty per reel
SOT23-5	8	4	7"	280	160	3000

Revision History

The revision history provided is for informational purpose only and is believed to be accurate, however, not warranted. Please make sure that you have the latest revision.

Date	Revision	Change
August 6, 2018	Revision 0.9	Initial Release

IMPORTANT NOTICE

- 1. Right to make changes.** Silergy and its subsidiaries (hereafter Silergy) reserve the right to change any information published in this document, including but not limited to circuitry, specification and/or product design, manufacturing or descriptions, at any time and without notice. This document supersedes and replaces all information supplied prior to the publication hereof. Buyers should obtain the latest relevant information before placing orders and should verify that such information is current and complete. All semiconductor products are sold subject to Silergy’s standard terms and conditions of sale.
- 2. Applications.** Application examples that are described herein for any of these products are for illustrative purposes only. Silergy makes no representation or warranty that such applications will be suitable for the specified use without further testing or modification. Buyers are responsible for the design and operation of their applications and products using Silergy products. Silergy or its subsidiaries assume no liability for any application assistance or designs of customer products. It is customer’s sole responsibility to determine whether the Silergy product is suitable and fit for the customer’s applications and products planned. To minimize the risks associated with customer’s products and applications, customer should provide adequate design and operating safeguards. Customer represents and agrees that it has all the necessary expertise to create and implement safeguards which anticipate dangerous consequences of failures, monitor failures and their consequences, lessen the likelihood of failures that might cause harm and take appropriate remedial actions. Silergy assumes no liability related to any default, damage, costs or problem in the customer’s applications or products, or the application or use by customer’s third-party buyers. Customer will fully indemnify Silergy, its subsidiaries, and their representatives against any damages arising out of the use of any Silergy components in safety-critical applications. It is also buyers’ sole responsibility to warrant and guarantee that any intellectual property rights of a third party are not infringed upon when integrating Silergy products into any application. Silergy assumes no responsibility for any said applications or for any use of any circuitry other than circuitry entirely embodied in a Silergy product.
- 3. Limited warranty and liability.** Information furnished by Silergy in this document is believed to be accurate and reliable. However, Silergy makes no representation or warranty, expressed or implied, as to the accuracy or completeness of such information and shall have no liability for the consequences of use of such information. In no event shall Silergy be liable for any indirect, incidental, punitive, special or consequential damages, including but not limited to lost profits, lost savings, business interruption, costs related to the removal or replacement of any products or rework charges, whether or not such damages are based on tort or negligence, warranty, breach of contract or any other legal theory. Notwithstanding any damages that customer might incur for any reason whatsoever, Silergy’ aggregate and cumulative liability towards customer for the products described herein shall be limited in accordance with the Standard Terms and Conditions of Sale of Silergy.
- 4. Suitability for use.** Customer acknowledges and agrees that it is solely responsible for compliance with all legal, regulatory and safety-related requirements concerning its products, and any use of Silergy components in its applications, notwithstanding any applications-related information or support that may be provided by Silergy. Silergy products are not designed, authorized or warranted to be suitable for use in life support, life-critical or safety-critical systems or equipment, nor in applications where failure or malfunction of an Silergy product can reasonably be expected to result in personal injury, death or severe property or environmental damage. Silergy assumes no liability for inclusion and/or use of Silergy products in such equipment or applications and therefore such inclusion and/or use is at the customer’s own risk.
- 5. Terms and conditions of commercial sale.** Silergy products are sold subject to the standard terms and conditions of commercial sale, as published at <http://www.silergy.com/stdterms>, unless otherwise agreed in a valid written individual agreement specifically agreed to in writing by an authorized officer of Silergy. In case an individual agreement is concluded only the terms and conditions of the respective agreement shall apply. Silergy hereby expressly objects to and denies the application of any customer’s general terms and conditions with regard to the purchase of Silergy products by the customer.
- 6. No offer to sell or license.** Nothing in this document may be interpreted or construed as an offer to sell products that is open for acceptance or the grant, conveyance or implication of any license under any copyrights, patents or other industrial or intellectual property rights. Silergy makes no representation or warranty that any license, either express or implied, is granted under any patent right, copyright, mask work right, or other intellectual property right. Information published by Silergy regarding third-party products or services does not constitute a license to use such products or services or a warranty or endorsement thereof. Use of such information may require a license from a third party under the patents or other intellectual property of the third party, or a license from Silergy under the patents or other intellectual property of Silergy.

For more information, please visit: www.silergy.com

© 2018 Silergy Corp.

All Rights Reserved.