

General Description

The SY26406 develops a high efficiency synchronous step-down DC/DC converter capable of delivering 0.6A current. The SY26406 operates over a wide input voltage range from 7V to 100V and integrates a main switch and a synchronous switch with very low $R_{DS(ON)}$ to minimize the conduction loss. The SY26406 always operates under Continuous Conduction Mode. The SY26406 adopts the instant PWM architecture to achieve fast transient responses for high step down applications.

Applications

- Isolated Telecom Bias Supply
- Secondary High Voltage Post Regulator
- Automotive Systems

Features

- Wide Input Voltage Range: 7-100V
- Internal 500mΩ Main Switch and 285mΩ Synchronous Switch
- 0.6A Output Current Capability
- COT Ripple-Based Control to Achieve Fast Transient Responses
- Programmable Switching Frequency Range: 200kHz~600kHz.
- 2ms Internal Soft-start Limits the Inrush Current
- Accurate Feedback Set Point: $1.225V \pm 2\%$
- Cycle-by-cycle Peak/Valley Current Limit
- Cycle-by-cycle Reverse Current Limit
- Auto Recovery for Over Temperature (OTP)
- RoHS Compliant and Halogen Free
- Compact Package: SO8E

Typical Applications

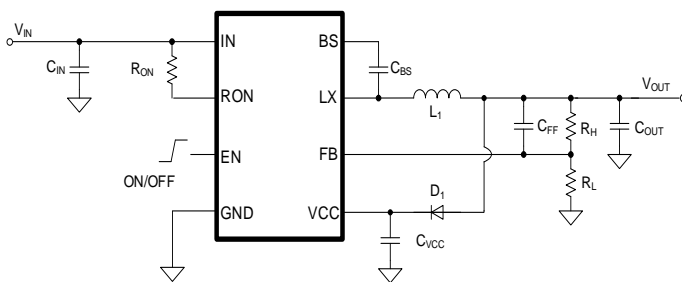

Figure1. Typical Application Circuit

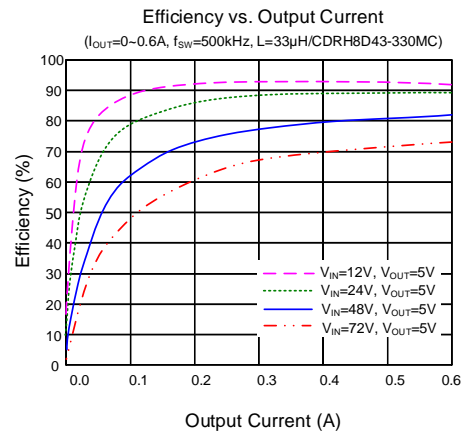

Figure2. Efficiency vs. Output Current

Ordering Information

Ordering Part Number	Package Type	Top Mark
SY26406FCC	SO8E RoHS Compliant and Halogen Free	DRDxyz

x = year code, y = week code, z = lot number code

Pinout (top view)

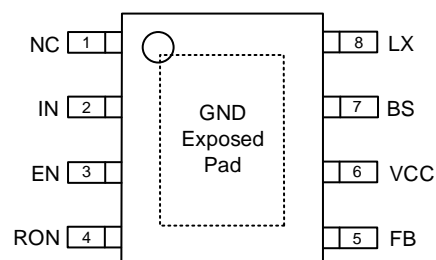

Pin Description

Pin Name	Pin Number	Pin Description
NC	1	Not connected.
IN	2	Input pin. Decouple this pin to GND with a low ESR ceramic capacitor.
EN	3	Enable control pin. This pin can also be used for programming V_{IN} turn on voltage with the resistor divider. The device has an accurate 1.225V rising threshold.
RON	4	Connect a resistor from this pin to the IN to set the top switch ON time. The switching frequency can be calculated using the following equation: $f_{sw} \text{ (kHz)} = \frac{11 \times V_{OUT} \text{ (V)} + 500}{R_{ON} \text{ (M}\Omega\text{)}}$
FB	5	Output feedback pin. Connect this pin to the center point of the output resistor divider (as shown in Figure 1) to program the output voltage: $V_{OUT} = 1.225 \times (1 + R_H/R_L)$
VCC	6	Supply input of internal LDO.
BS	7	Boot-Strap Pin. Supply high side gate driver. Connect a 0.1 μ F ceramic capacitor between the BS pin and the LX pin.
LX	8	Inductor pin. Connect this pin to the switching node of inductor.
GND	Exposed Pad	Ground pin.



Block Diagram

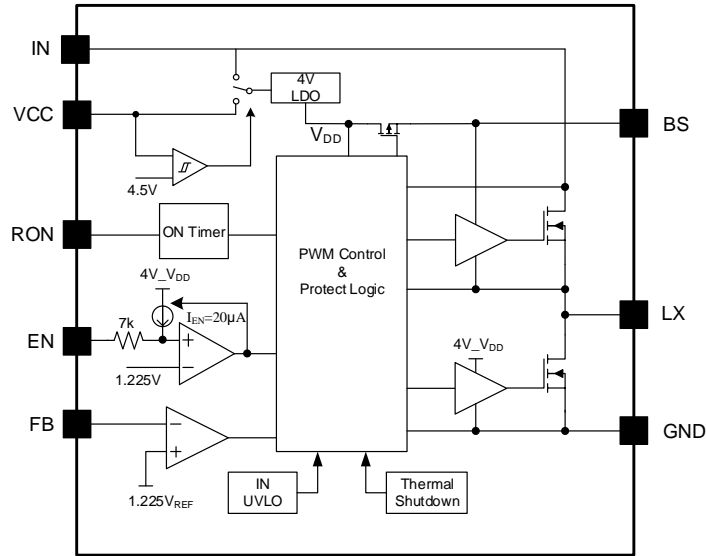

Figure3. Block Diagram

Absolute Maximum Ratings (1)	Min	Max	Unit
IN	-0.3	100	V
EN, RON	-0.3	IN+ 0.3	
LX	-0.3	IN+ 0.3	
BS-LX, FB	-0.3	6	
VCC	-0.3	30	
LX, 50ns duration	IN+3	GND-5	
Junction Temperature, Operating	-40	150	°C
Lead Temperature (Soldering, 10sec.)		260	
Storage Temperature	-65	150	

Thermal Information (2)	Typ	Unit
θ_{JA} Junction-to-ambient Thermal Resistance	30	°C/W
θ_{JC} Junction-to-case Thermal Resistance	10	
P_D Power Dissipation $T_A=25^\circ\text{C}$	3.3	W

Recommended Operating Conditions (3)	Min	Max	Unit
IN	7	100	V
Ambient Temperature	-40	85	°C
Junction Temperature	-40	125	

Electrical Characteristics

($V_{IN} = 48V$, $V_{OUT} = 5V$, $L = 33\mu H$, $C_{OUT} = 10\mu F$, $I_{OUT} = 0.6A$ unless otherwise specified. Typical value corresponds to $T_J = 25^\circ C$. Minimum and maximum limits apply over $-40^\circ C$ to $125^\circ C$ junction temperature range.)

Parameter	Symbol	Test Conditions	Min	Typ	Max	Unit
Input Voltage Range	V_{IN}		7		100	V
Input UVLO Rising Threshold	$V_{IN,UVLO}$		5.8	6.3	6.8	V
Input UVLO Hysteresis	V_{HYS}			0.25		V
Shutdown Current	I_{SHDN}	EN=0		8	30	μA
Feedback Reference Voltage	V_{REF}		1.2	1.225	1.25	V
FB Input Current	I_{FB}	$V_{FB}=3.3V$	-100		100	nA
Top FET RON	$R_{DS(ON)1}$			500		m Ω
Bottom FET RON	$R_{DS(ON)2}$			285		m Ω
Top FET peak Current Limit	$I_{LIM, TOP}$		0.9	1.2	1.5	A
Bottom FET Valley Current Limit	$I_{LIM, BOTTOM}$		0.6	0.8	1	A
Negative Current Limit	$I_{LIM, NEG}$		-480	-650	-820	mA
VCC Input Rising UVLO Threshold	$V_{VCC, UVLO}$			4.5		V
VCC Input UVLO Hysteresis	$V_{VCC, HYS}$			0.3		V
EN Rising Threshold	V_{EN}		1.185	1.225	1.265	V
EN Hysteresis Input Current	$I_{EN, HYS}$		-10	-20	-29	μA
Switching Frequency	f_{OSC}	$V_{IN}=48V$, $R_{ON}=1.1M\Omega$	350	500	650	kHz
Min ON Time	t_{ON}			90		ns
Min OFF Time	t_{OFF}			200		ns
Thermal Shutdown Temperature	T_{SD}			150		$^\circ C$
Thermal Shutdown Hysteresis	T_{HYS}			15		$^\circ C$

Note 1: Stresses beyond the “Absolute Maximum Ratings” may cause permanent damage to the device. These are stress ratings only. Functional operation of the device at these or any other conditions beyond those indicated in the operational sections of the specification is not implied. Exposure to absolute maximum rating conditions for extended periods may affect device reliability.

Note 2: θ_{JA} is measured in the natural convection at $T_A = 25^\circ C$ on a low effective 4-layer thermal conductivity test board of JEDEC 51-3 thermal measurement standard. Paddle of SO8E packages is the case position for θ_{JC} measurement.

Note 3: The device is not guaranteed to function outside its operating conditions.

Typical Performance Characteristics

($T_A = 25^\circ\text{C}$, $V_{IN} = 48\text{V}$, $V_{OUT} = 5\text{V}$, $L = 33\mu\text{H}$, $C_{OUT} = 10\mu\text{F}$, $f_{SW} = 500\text{kHz}$, unless otherwise noted)

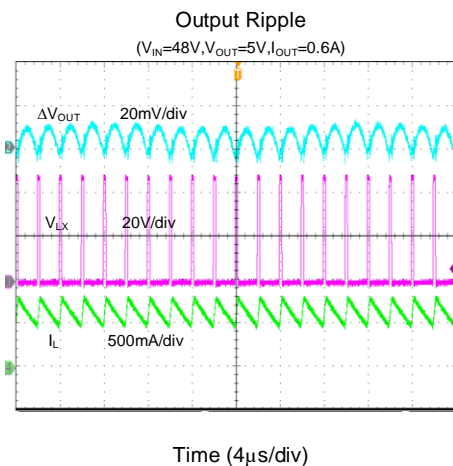
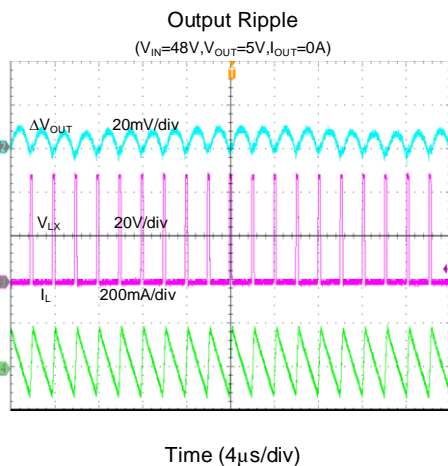
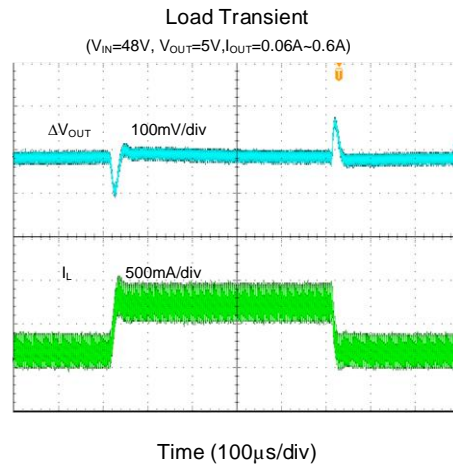
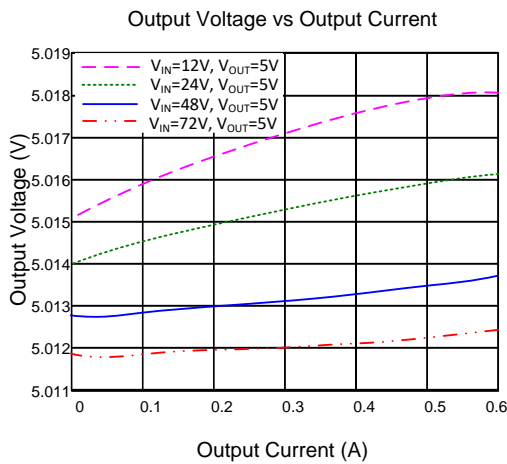
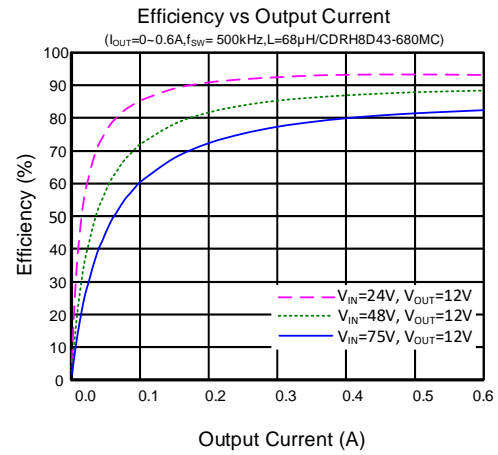
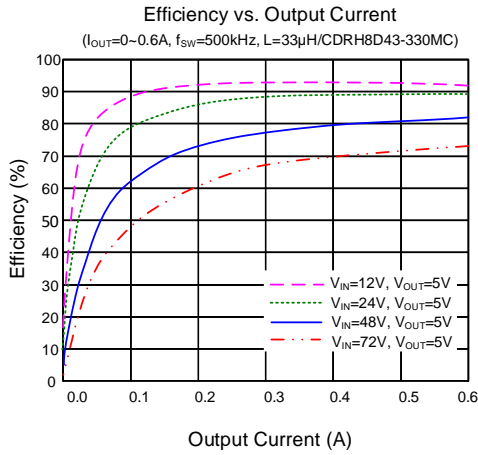

Startup from V_{IN}
($V_{IN}=48V$, $V_{OUT}=5V$, $I_{OUT}=0A$)

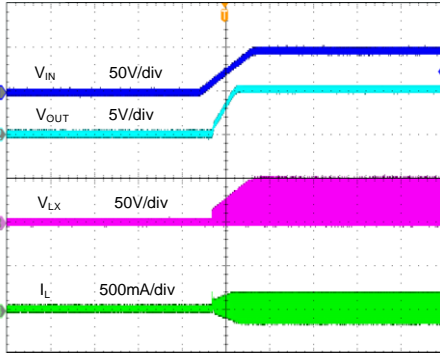

Time (4ms/div)

Shutdown from V_{IN}
($V_{IN}=48V$, $V_{OUT}=5V$, $I_{OUT}=0A$)

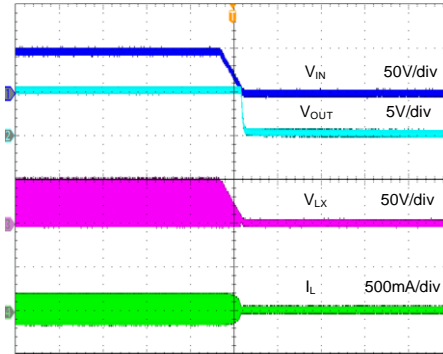

Time (200ms/div)

Startup from V_{IN}
($V_{IN}=48V$, $V_{OUT}=5V$, $I_{OUT}=0.6A$)

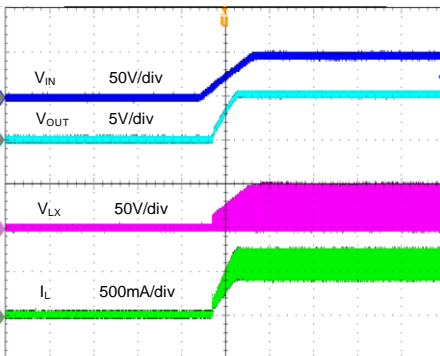

Time (4ms/div)

Shutdown from V_{IN}
($V_{IN}=48V$, $V_{OUT}=5V$, $I_{OUT}=0.6A$)

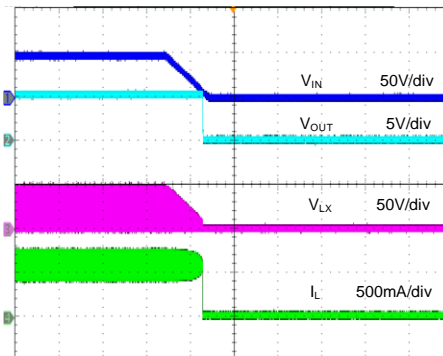

Time (100ms/div)

Startup from EN
($V_{IN}=48V$, $V_{OUT}=5V$, $I_{OUT}=0A$)

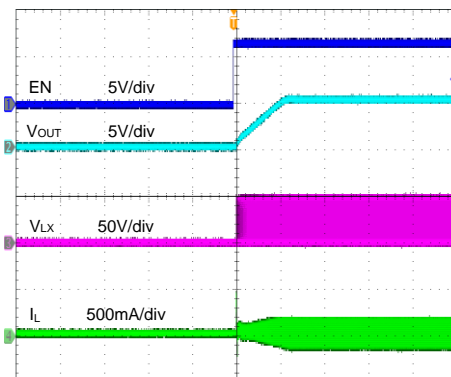

Time (2ms/div)

Shutdown from EN
($V_{IN}=48V$, $V_{OUT}=5V$, $I_{OUT}=0A$)

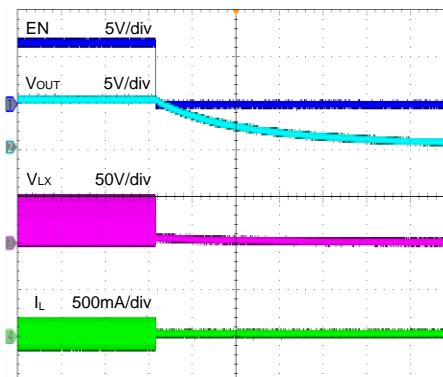

Time (400ms/div)

Startup from EN

($V_{IN}=48V$, $V_{OUT}=5V$, $I_{OUT}=0.6A$)

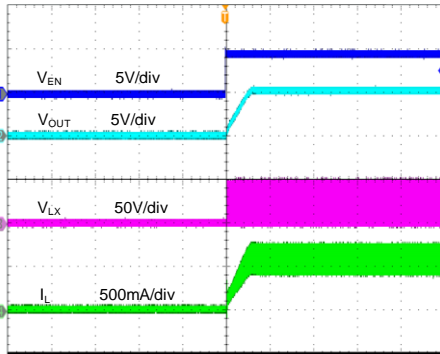

Time (4ms/div)

Shutdown from EN

($V_{IN}=48V$, $V_{OUT}=5V$, $I_{OUT}=0.6A$)

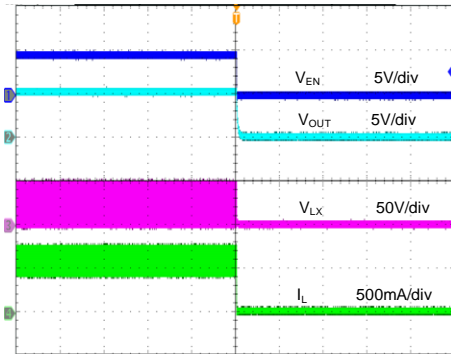

Time (4ms/div)

Short Circuit Protection

($V_{IN}=48V$, $V_{OUT}=5V$, $I_{OUT}=0A$ ~Short)

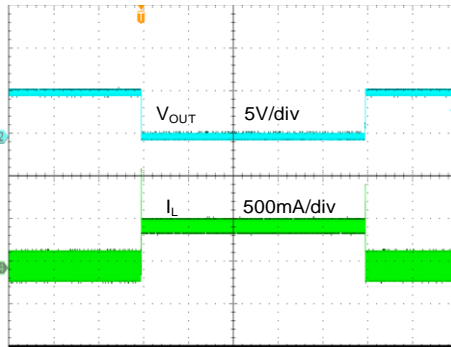

Time (10ms/div)

Short Circuit Protection

($V_{IN}=48V$, $V_{OUT}=5V$, $I_{OUT}=0.6A$ ~Short)

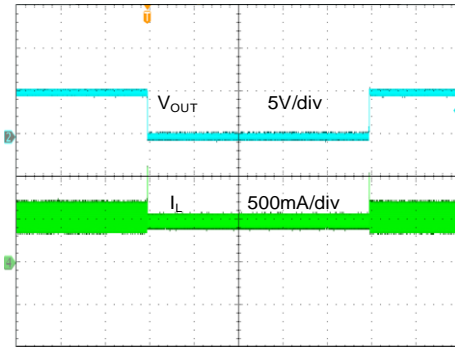

Time (10ms/div)

Bode Plot

($V_{IN}=48V$, $V_{OUT}=5V$, $I_{OUT}=0.6A$, $L=33\mu H$)

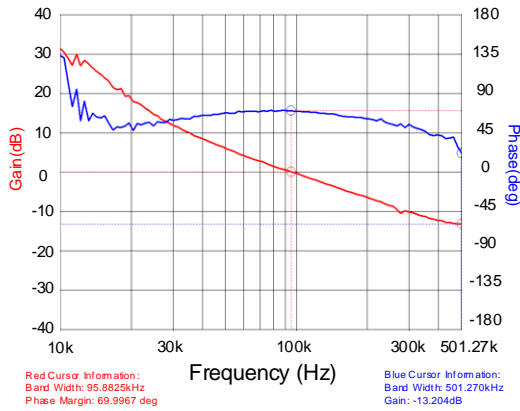

Bode Plot

($V_{IN}=48V$, $V_{OUT}=12V$, $I_{OUT}=0.6A$, $L=68\mu H$)

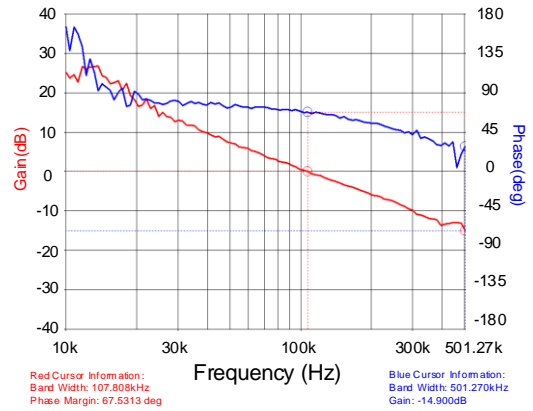

Detailed Description

The SY26406 is highly integrated, so only the input capacitor C_{IN} , the output capacitor C_{OUT} , the output inductor L , and the feedback resistors R_H and R_L need to be selected for the targeted application specifications.

Output Voltage Program

Choose R_1 and R_2 to program the proper output voltage. To minimize the power consumption under light loads, it is desirable to choose large resistance values for both R_1 and R_2 .

$$V_{OUT} = \left(1 + \frac{R_1}{R_2}\right) \times V_{FB}$$

1.225V is a typical value for V_{FB} .

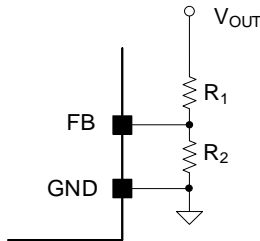

Output Inductor L

There are several considerations in choosing this inductor:

- 1) Choose the inductance to provide a ripple current that is approximately 40% of the maximum output current. The inductance is calculated as:

$$L_1 = \frac{V_{OUT} \times (1 - V_{OUT} / V_{IN_MAX})}{f_{SW} \times I_{OUT_MAX} \times 40\%}$$

Where f_{SW} is the switching frequency and I_{OUT_MAX} is the maximum load current.

The SY26406 regulator is quite tolerant of different ripple current amplitude. Consequently, the final choice of inductance can be slightly off the calculated value without significantly impacting the performance.

- 2) The saturation current rating of the inductor must be selected greater than the peak inductor current under full load conditions.

$$I_{SAT_MIN} > I_{OUT_MAX} + \frac{V_{OUT} \times (1 - V_{OUT} / V_{IN_MAX})}{2f_{SW} \times L_1}$$

The DCR of the inductor and the core loss at the switching frequency must be low enough to achieve the desired efficiency requirement. It is desirable to choose

an inductor with smaller DCR to achieve a good overall efficiency.

Input Capacitor C_{IN}

The ripple current through the input capacitor is calculated as:

$$I_{CIN_RMS} = I_{OUT_MAX} \times \sqrt{D(1-D)}$$

The capacitance of the input capacitor is calculated as:

$$C_{IN} = \frac{I_{OUT} \times V_{OUT} \times (V_{IN} - V_{OUT})}{\Delta V_{IN} \times f_{SW} \times \eta \times V_{IN}^2}$$

ΔV_{IN} is desired input voltage ripple. η is the efficiency.

To minimize the potential noise problem, a typical X5R or a better grade ceramic capacitor is placed really close to the IN and the GND pins. Care should be taken to minimize the loop area formed by C_{IN} and the IN/GND pins. In this case, a 1 μ F low ESR ceramic capacitor is recommended.

Output Capacitor C_{OUT}

The output capacitor is selected to handle the output ripple noise requirements. Both steady state ripple and transient requirements must be taken into consideration when selecting this capacitor. It is recommended to use an X5R or a better grade ceramic capacitor with greater than 10 μ F capacitance.

On-time

The on-time for the SY26406 is determined by the R_{ON} resistor, and is inversely proportional to the input voltage, resulting in a nearly constant frequency as V_{IN} is varied over its range. The required on-time adjust resistance for various frequencies and output voltages are given in Table 1.

Frequency vs. R_{ON} Resistor:

$$f_{SW} \text{ (kHz)} = \frac{11 \times V_{OUT} \text{ (V)} + 500}{R_{ON} \text{ (M}\Omega\text{)}}$$

Table 1. On-Time Adjust Resistance For Various Frequencies and Output Voltages

f_{SW} (kHz)	R_{ON} (M Ω)			
	$V_{OUT} = 1.8V$	$V_{OUT} = 5V$	$V_{OUT} = 12V$	$V_{OUT} = 24V$
200	2.6	2.8	3.15	3.8
400	1.3	1.4	1.6	1.9
600	0.85	0.9	1.05	1.3

Notice: Final switch frequency is not only affected by the tolerance of component but also by minimum off and on-time limit.

Internal LDO Regulator

The SY26406 has two power supply ways for 4V LDO. Upon power up, the 4V LDO regulator will be power supplied by V_{IN} . When the voltage on the VDD reaches the under-voltage lockout threshold voltage, the Buck regulator will be enabled. After soft-start is done, if the VCC pin voltage is larger than 4.5V, the power supply of 4V LDO will be switched to VCC. A 0.1 μ F ceramic capacitor is recommended for C_{VCC} in most applications.

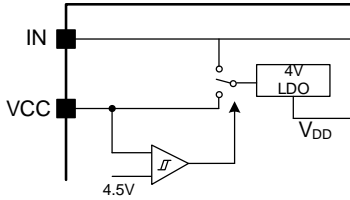

In applications, the input pin (IN) can be connected directly to the line voltage up to 100 Volts, where power dissipation in the 4V LDO regulator is a concern, an auxiliary voltage can be connected to the VCC pin via a diode. Setting the auxiliary voltage to 4.8 -28V will shut off the LDO power supply from IN and reduce internal LDO power dissipation.

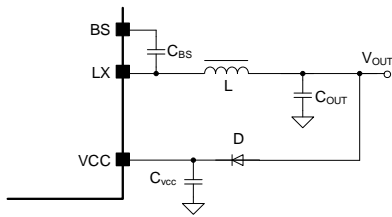

Soft-start

The SY26406 has a built-in soft-start to control the rise rate of the output voltage and limit the input current surge during the IC start-up. The typical soft-start time is 2ms.

Adjusting Under Voltage Lockout

The EN pin provides electrical on/off control of the device. Once the EN pin voltage exceeds the threshold voltage, the device will start to operate. If the EN pin voltage is pulled below the threshold, the regulator will stop switching and enter shutdown state. An external set-point voltage divider from V_{IN} to GND can be used for setting the minimum operating voltage of the regulator. Minimum V_{UVLO} value needs larger than 6.8V.

$$V_{IN,UVLO}(V) = \left(1 + \frac{R_{EN1}}{R_{EN2}}\right) \times V_{EN}$$

1.225V is a typical value for V_{EN} .

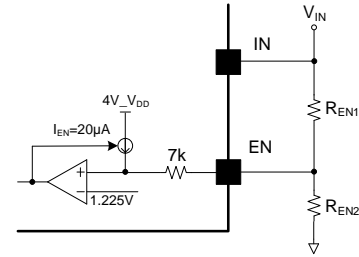

UVLO hysteresis is accomplished with an internal 20 μ A current source that is switched on or off into the impedance of the set-point divider. When the EN threshold is exceeded, the current source will be activated to quickly raise the voltage at the EN pin. The UVLO hysteresis is calculated as

$$V_{HYS}(V) = I_{EN} \times R_{EN1} + I_{EN} \times 7k \times \left(1 + \frac{R_{EN1}}{R_{EN2}}\right)$$

Load Transient Considerations

The SY26406 regulator adopts COT ripple-based control to achieve good stability and fast transient responses. Adding a C_{FF} ceramic capacitor in parallel with R_1 is recommended.

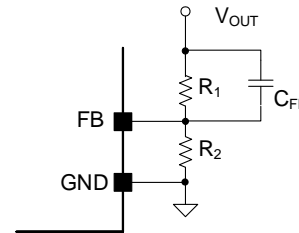

External Boot-strap Capacitor

This capacitor provides the gate driver voltage for internal high side MOSFET. A 100nF low ESR ceramic capacitor connected between the BS pin and the LX pin is recommended.

Over Current Protection

The SY26406 provides cycle-by-cycle over current limit on both high side MOSFET and low-side MOSFET. Under over current condition, if the output voltage drops below 33% of set-point, the device will fold back valley current limit to 0.5x typical value.



SY26406FCC

Over-temperature Protection (OTP)

The device includes over-temperature protection (OTP) circuitry to prevent overheating due to excessive power dissipation. This will shut down switching operation when the junction temperature exceeds 150°C. Once the

junction temperature cools down by approximately 15°C, the IC will resume normal operation after a complete soft-start cycle. For continuous operation, provide adequate cooling so that the junction temperature will not exceed the OTP threshold

Application Schematic ($V_{OUT} = 5V$)

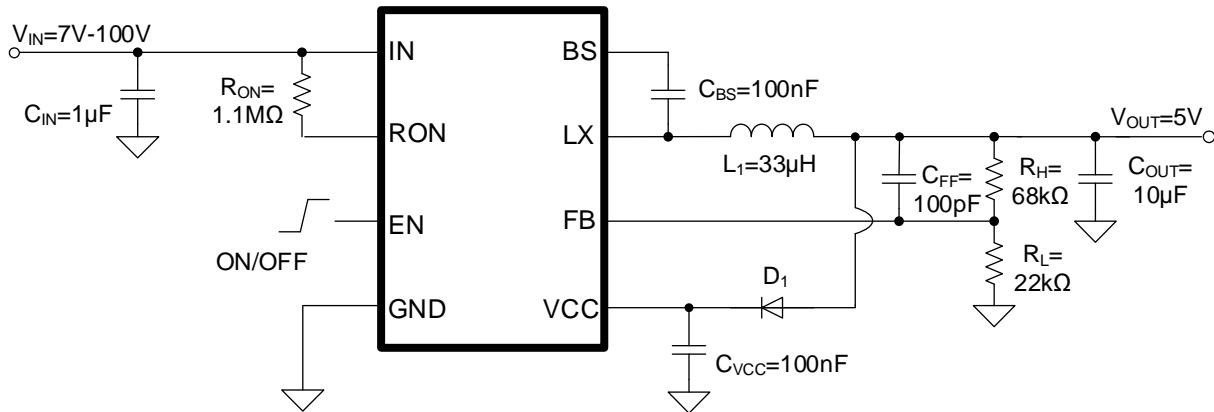

Figure 4. Buck Schematic

BOM List

Designator	Description	Part Number	Manufacturer
C_{IN}	1µF/100V/X7R, 1206	C3216X7R2A105K	TDK
C_{OUT}	10µF/25V/X5R, 1206	C3216X5R1E106M	TDK
C_{VCC}	0.1µF/50V/X7R, 0603	C1608X7R1H104K	TDK
C_{BS}	0.1µF/50V/X7R, 0603	C1608X7R1H104K	TDK
C_{FF}	100pF/50V/X5R, 0603	C1608C0G1H101J	TDK
L	33µH, inductor	CDRH8D43-330NC	Sumida
R_{ON}	1.1MΩ, 1%, 0603		
R_H	68kΩ, 1%, 0603		
R_L	22kΩ, 1%, 0603		
D1	BAT54		

Recommend Table for Typical Applications

$V_{OUT}(V)$	$R_H(k\Omega)$	$R_L(k\Omega)$	$C_{FF}(pF)$	$L_1/Part Number$
5	68	22	100	33µH/CDRH8D43-330NC
12	105	12	220	68µH/CDRH8D43-680NC

Application Schematic ($V_{OUT} = 5V$)

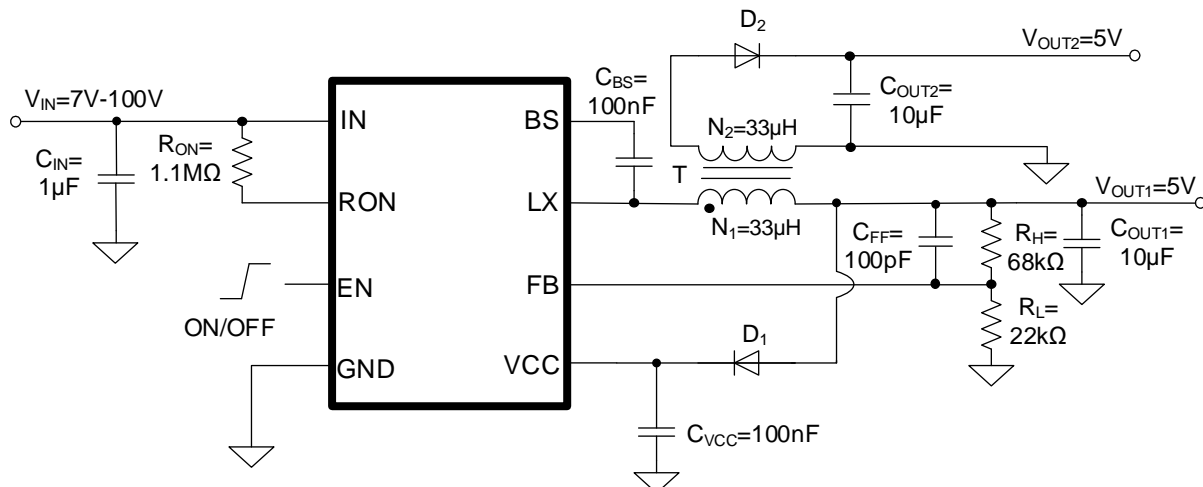

Figure 5. Fly-Buck Schematic

BOM List

Designator	Description	Part Number	Manufacturer
C_{IN}	1µF/100V/X7R, 1206	C3216X7R2A105K	TDK
C_{OUT1}	10µF/25V/X5R, 1206	C3216X5R1E106M	TDK
C_{OUT2}	10µF/25V/X5R, 1206	C3216X5R1E106M	TDK
C_{VCC}	0.1µF/50V/X7R, 0603	C1608X7R1H104K	TDK
C_{BS}	0.1µF/50V/X7R, 0603	C1608X7R1H104K	TDK
C_{FF}	100pF/50V/X5R, 0603	C1608C0G1H101J	TDK
T	$N_1:33\mu H, N_2:33\mu H$		
R_{ON}	1.1MΩ, 1%, 0603		
R_H	68kΩ, 1%, 0603		
R_L	22kΩ, 1%, 0603		
D1	BAT54		
D2	SS310		

Recommend Table for Typical Applications

$V_{OUT}(V)$	$R_H(k\Omega)$	$R_L(k\Omega)$	$C_{FF}(pF)$	T(µH)
5	68	22	100	33
12	105	12	220	68

Application Schematic ($V_{OUT} = -5V$)

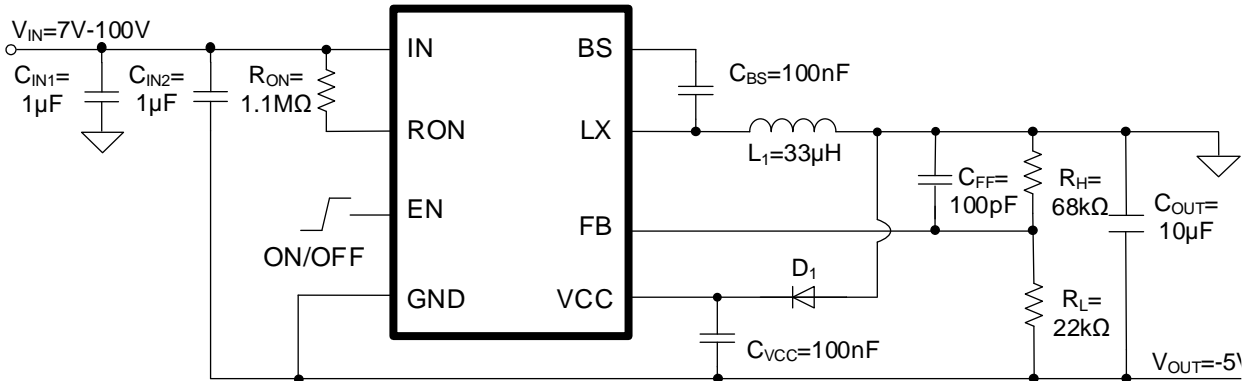

Figure 6. Buck-Boost Schematic

BOM List

Designator	Description	Part Number	Manufacturer
C_{IN1}	1µF/100V/X7R, 1206	C3216X7R2A105K	TDK
C_{IN2}	1µF/100V/X7R, 1206	C3216X7R2A105K	TDK
C_{OUT}	10µF/25V/X5R, 1206	C3216X5R1E106M	TDK
C_{VCC}	0.1µF/50V/X7R, 0603	C1608X7R1H104K	TDK
C_{BS}	0.1µF/50V/X7R, 0603	C1608X7R1H104K	TDK
C_{FF}	100pF/50V/X5R, 0603	C1608C0G1H101J	TDK
L	33µH, inductor	CDRH8D43-330NC	Sumida
R_{ON}	1.1MΩ, 1%, 0603		
R_H	68kΩ, 1%, 0603		
R_L	22kΩ, 1%, 0603		
D_1	BAT54		

Recommend Table for Typical Applications

$V_{OUT}(V)$	$R_H(k\Omega)$	$R_L(k\Omega)$	$C_{FF}(pF)$	$L_1/Part Number$
5	68	22	100	33µH/CDRH8D43-330NC
12	105	12	220	68µH/CDRH8D43-680NC

Layout Design

For optimal design, follow these PCB layout considerations:

- It is desirable to maximize the PCB copper area connecting to the GND pin to achieve the best thermal and noise performance. If the board space allowed, a ground plane is highly desirable.
- C_{IN} must be close to the pins IN and GND. The loop area formed by C_{IN} and GND must be minimized.
- C_{VCC} should be placed close to the VCC pin and the GND pin.
- The PCB copper area associated with the LX pin must be minimized to avoid the potential noise problem.

- The feedback components R_H and R_L and the trace connecting to the FB pin must NOT be adjacent to the LX net on the PCB layout to avoid the noise problem.
- If the system chip interfacing with the EN pin has a high impedance state at shutdown mode and the IN pin is connected directly to a power source such as a Li-Ion battery, it is desirable to add a pull-down 1M Ω resistor between the EN and the GND pins to prevent the noise from falsely turning on the regulator at shutdown mode.

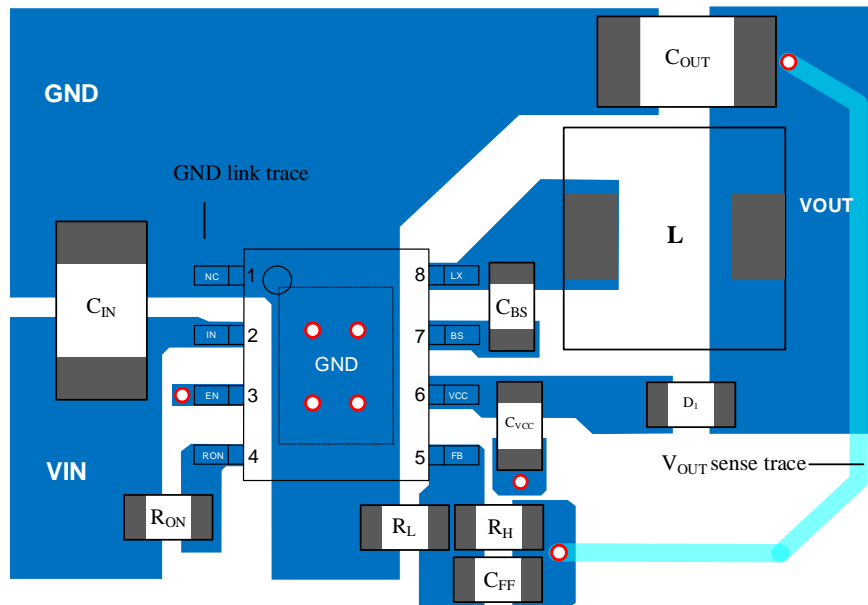
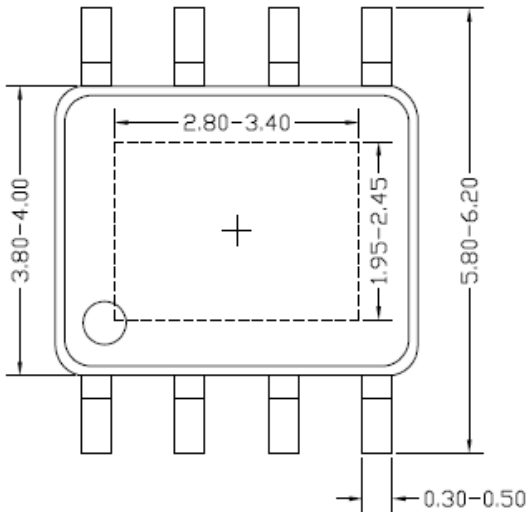
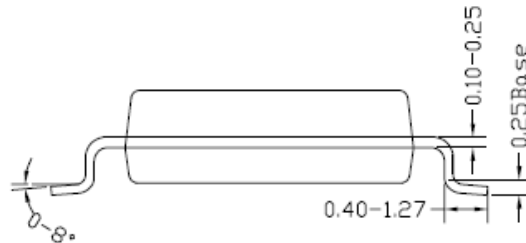

Figure7. PCB Layout Suggestion

SO8E Package Outline & PCB Layout



Top view



Side view

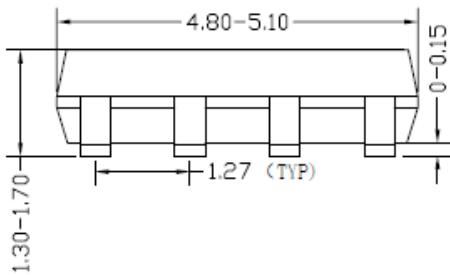

Front view

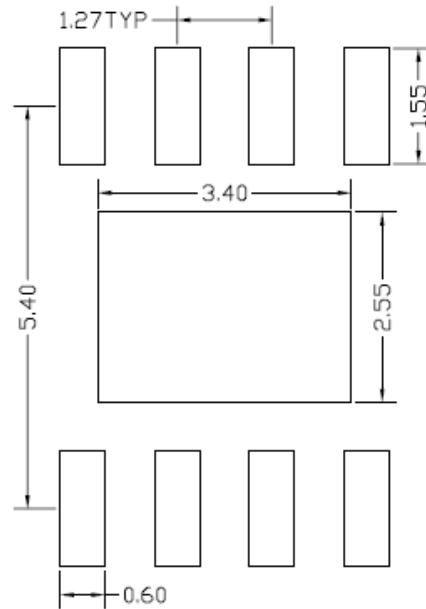

**Recommended PCB layout
(Reference Only)**

Notes: All dimension in millimeter and exclude mold flash & metal burr.

Taping & Reel Specification

1. Taping orientation

SO8E

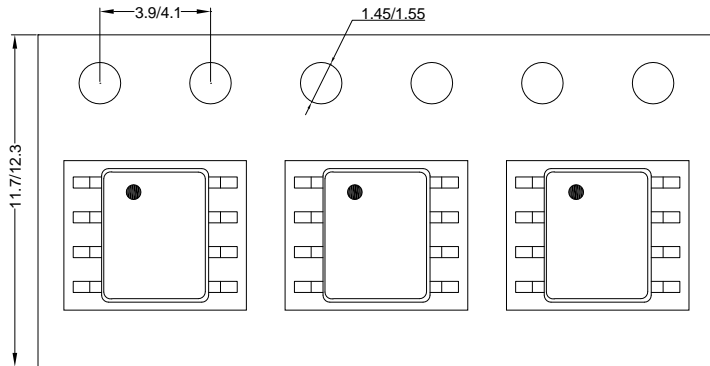

Feeding direction →

2. Carrier Tape & Reel specification for packages

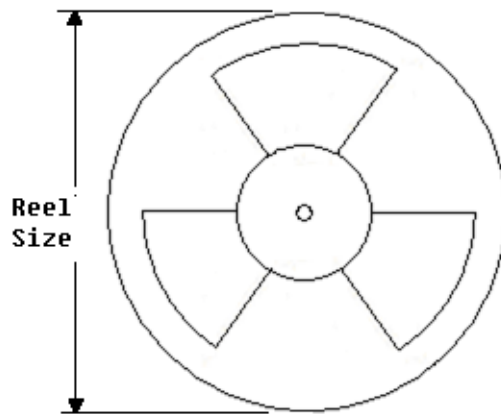

Package type	Tape width (mm)	Pocket pitch(mm)	Reel size (Inch)	Trailer length(mm)	Leader length (mm)	Qty per reel
SO8E	12	8	13"	400	400	2500

3. Others: NA



IMPORTANT NOTICE

1. **Right to make changes.** Silergy and its subsidiaries (hereafter Silergy) reserve the right to change any information published in this document, including but not limited to circuitry, specification and/or product design, manufacturing or descriptions, at any time and without notice. This document supersedes and replaces all information supplied prior to the publication hereof. Buyers should obtain the latest relevant information before placing orders and should verify that such information is current and complete. All semiconductor products are sold subject to Silergy's standard terms and conditions of sale.

2. **Applications.** Application examples that are described herein for any of these products are for illustrative purposes only. Silergy makes no representation or warranty that such applications will be suitable for the specified use without further testing or modification. Buyers are responsible for the design and operation of their applications and products using Silergy products. Silergy or its subsidiaries assume no liability for any application assistance or designs of customer products. It is customer's sole responsibility to determine whether the Silergy product is suitable and fit for the customer's applications and products planned. To minimize the risks associated with customer's products and applications, customer should provide adequate design and operating safeguards. Customer represents and agrees that it has all the necessary expertise to create and implement safeguards which anticipate dangerous consequences of failures, monitor failures and their consequences, lessen the likelihood of failures that might cause harm and take appropriate remedial actions. Silergy assumes no liability related to any default, damage, costs or problem in the customer's applications or products, or the application or use by customer's third-party buyers. Customer will fully indemnify Silergy, its subsidiaries, and their representatives against any damages arising out of the use of any Silergy components in safety-critical applications. It is also buyers' sole responsibility to warrant and guarantee that any intellectual property rights of a third party are not infringed upon when integrating Silergy products into any application. Silergy assumes no responsibility for any said applications or for any use of any circuitry other than circuitry entirely embodied in a Silergy product.

3. **Limited warranty and liability.** Information furnished by Silergy in this document is believed to be accurate and reliable. However, Silergy makes no representation or warranty, expressed or implied, as to the accuracy or completeness of such information and shall have no liability for the consequences of use of such information. In no event shall Silergy be liable for any indirect, incidental, punitive, special or consequential damages, including but not limited to lost profits, lost savings, business interruption, costs related to the removal or replacement of any products or rework charges, whether or not such damages are based on tort or negligence, warranty, breach of contract or any other legal theory. Notwithstanding any damages that customer might incur for any reason whatsoever, Silergy' aggregate and cumulative liability towards customer for the products described herein shall be limited in accordance with the Standard Terms and Conditions of Sale of Silergy.

4. **Suitability for use.** Customer acknowledges and agrees that it is solely responsible for compliance with all legal, regulatory and safety-related requirements concerning its products, and any use of Silergy components in its applications, notwithstanding any applications-related information or support that may be provided by Silergy. Silergy products are not designed, authorized or warranted to be suitable for use in life support, life-critical or safety-critical systems or equipment, nor in applications where failure or malfunction of Silergy product can reasonably be expected to result in personal injury, death or severe property or environmental damage. Silergy assumes no liability for inclusion and/or use of Silergy products in such equipment or applications and therefore such inclusion and/or use is at the customer's own risk.

5. **Terms and conditions of commercial sale.** Silergy products are sold subject to the standard terms and conditions of commercial sale, as published at <http://www.silergy.com/stdterms>, unless otherwise agreed in a valid written individual agreement specifically agreed to in writing by an authorized officer of Silergy. In case an individual agreement is concluded only the terms and conditions of the respective agreement shall apply. Silergy hereby expressly objects to and denies the application of any customer's general terms and conditions with regard to the purchase of Silergy products by the customer.

6. **No offer to sell or license.** Nothing in this document may be interpreted or construed as an offer to sell products that is open for acceptance or the grant, conveyance or implication of any license under any copyrights, patents or other industrial or intellectual property rights. Silergy makes no representation or warranty that any license, either express or implied, is granted under any patent right, copyright, mask work right, or other intellectual property right. Information published by Silergy regarding third-party products or services does not constitute a license to use such products or services or a warranty or endorsement thereof. Use of such information may require a license from a third party under the patents or other intellectual property of the third party, or a license from Silergy under the patents or other intellectual property of Silergy.

For more information, please visit: www.silergy.com

©2021 Silergy Corp.

All Rights Reserved.