



**SILERGY**

# SY6301B

## Super Low Dropout 1A LDO Regulator

### General Description

The SY6301B is a super low dropout LDO regulator with 3.3V fixed output voltage, capable of delivering up to 1A output current.

### Ordering Information

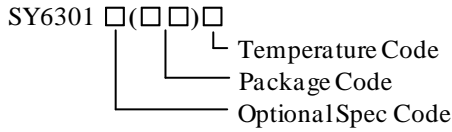

Ordering Number	Package type	Note
SY6301BAJC	SOT-223	

### Features

- Input Voltage Range: 1.6-5.5V
- Output Voltage Accuracy:  $\pm 3\%$
- Up to 1A Output Current
- Current Limiting Protection
- Quiescent Current: 80 $\mu$ A
- Over Temperature Protection
- RoHS Compliant and Halogen Free
- Compact Package: SOT-223

### Applications

- Portable Communication Equipment
- Hand-Held Instruments, Notebook PC
- Camcorders and Cameras

### Typical Application

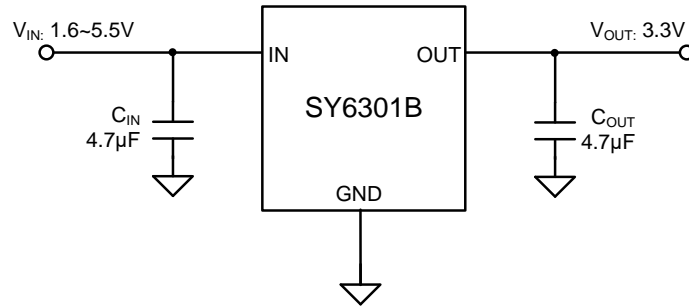
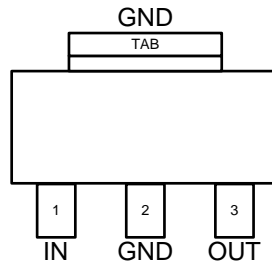

Figure1. Schematic Diagram

### Pinout (Top view)



(SOT-223)

Top Mark: **CSDxyz**, (Device code: CSD, *x*=year code, *y*=week code, *z*=lot number code)

Pin Name	Pin NO.	Pin Description
IN	1	Input pin. Decouple this pin to the GND pin with at least a 4.7 $\mu$ F ceramic capacitor.
GND	2, TAB	Ground pin.
OUT	3	Output pin. Decouple this pin to the GND pin with at least a 4.7 $\mu$ F ceramic capacitor.

**Block Diagram**

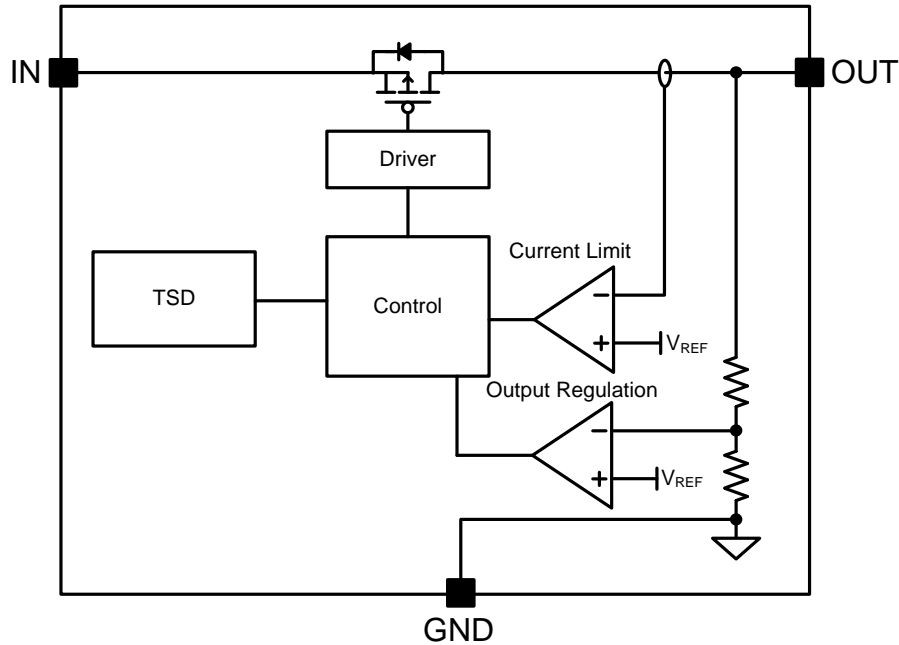

Figure2. Block Diagram

**Absolute Maximum Ratings** (Note 1)

IN, OUT	-----	-0.3V to 6V
Power Dissipation, Pd @ TA = 25°C	-----	2.78W
Package Thermal Resistance (Note 2)	-----	
θJA	-----	36°C/W
θJC	-----	3.44°C/W
Junction Temperature Range	-----	-40°C to +150°C
Lead Temperature (Soldering, 10 sec.)	-----	260°C
Storage Temperature Range	-----	-65°C to 150°C

**Recommended Operating Conditions** (Note 3)

IN	-----	1.6V to 5.5V
OUT	-----	0V to 5.5V
Junction Temperature Range	-----	-40°C to 125°C
Ambient Temperature Range	-----	-40°C to 85°C

**Electrical Characteristics**

 ( $V_{IN}=5V$ ,  $C_{IN}=4.7\mu F$ ,  $T_A = 25^\circ C$ , unless otherwise specified)

Parameter	Symbol	Test Conditions	Min	Typ	Max	Unit
Input Voltage Range	$V_{IN}$		1.6		5.5	V
Supply Current	$I_{SS}$	$V_{IN}=5V$ , $V_{OUT}=3.3V$ , $I_{OUT}=0A$		80	110	$\mu A$
Output Voltage Accuracy	$\Delta V_{OUT}$	$V_{IN}=5V$ , $I_{OUT}=100mA$	3.201	3.3	3.399	V
Current Limit	$I_{LMT}$		1			A
Load Regulation	$\Delta V_{LD\_REG}$	$V_{IN}=5V$ , $1mA \leq I_{OUT} \leq 1A$		-10		mV/A
Line Regulation	$\Delta V_{LN\_REG}$	$2V \leq V_{IN} \leq 5.5V$ , $I_{OUT}=100mA$		0.22	0.55	%/V
Power Supply Ripple Rejection	PSRR	$V_{IN}=5V$ , $V_{OUT}=3.3V$ , $I_{OUT}=100mA$ , $f=1kHz$		-60		dB
Output Voltage Temperature Coefficient	$\Delta V_{TMP\_SHFT}$	$I_{OUT}=100mA$ , $-40^\circ C \leq T_J \leq 85^\circ C$		$\pm 100$		ppm/ $^\circ C$
Short Current Limit	$I_{SHORT}$	$V_{OUT}=0V$		350		mA
Dropout Voltage	$\Delta V_{DROP}$	$I_{OUT}=1A$		0.2		V
Thermal shutdown threshold	$T_{SD}$			150		$^\circ C$
Thermal Shutdown Hysteresis	$T_{HYS}$			20		$^\circ C$

**Note 1:** Stresses beyond the “Absolute Maximum Ratings” may cause permanent damage to the device. These are stress ratings only. Functional operation of the device at these or any other conditions beyond those indicated in the operational sections of the specification is not implied. Exposure to absolute maximum rating conditions for extended periods may affect device reliability.

**Note 2:**  $\theta_{JA}$  is measured in the natural convection at  $T_A = 25^\circ C$  on Silergy test board.

**Note 3:** The device is not guaranteed to function outside its operating conditions.

## Typical Operating Characteristics

Input Supply Current vs. Supply Voltage

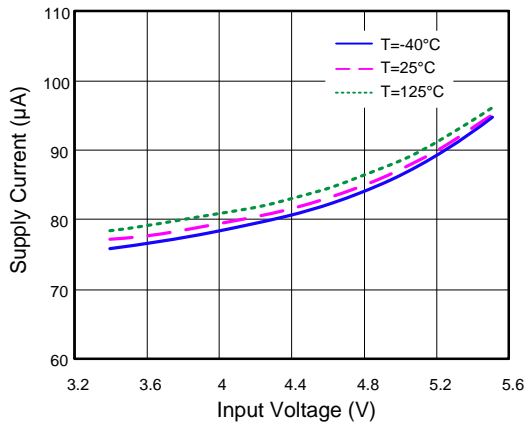

Output Voltage vs. Temperature  
( $V_{IN}=5V, I_{OUT}=100mA$ )

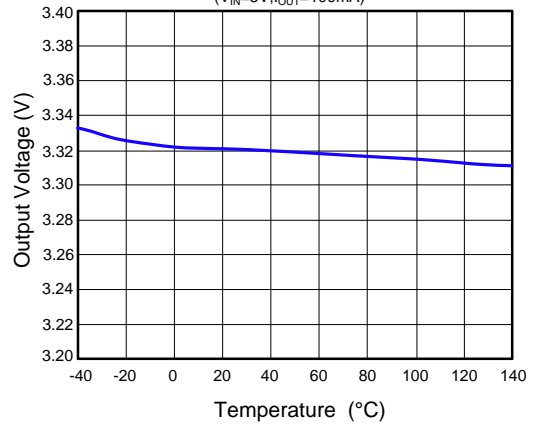

Load Regulation

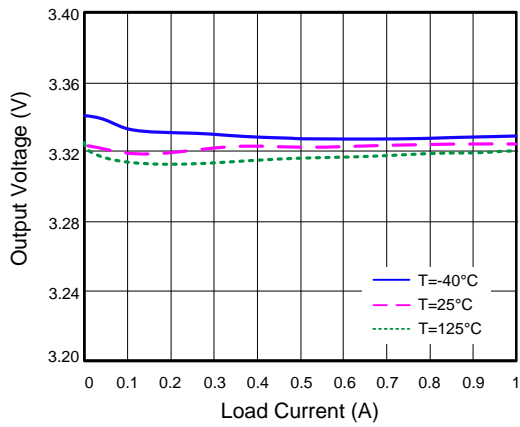

Line Regulation

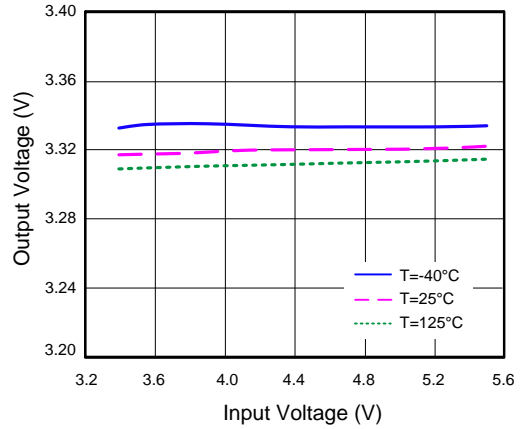

Dropout Voltage vs. Load Current

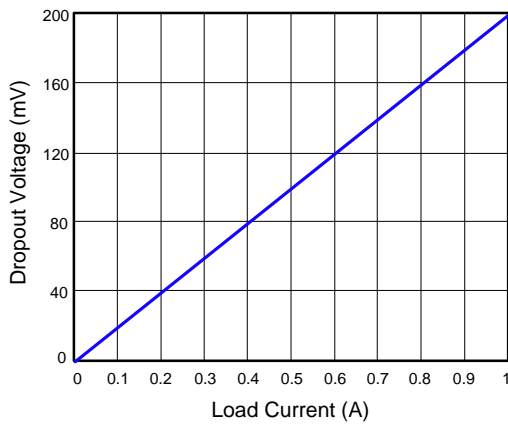

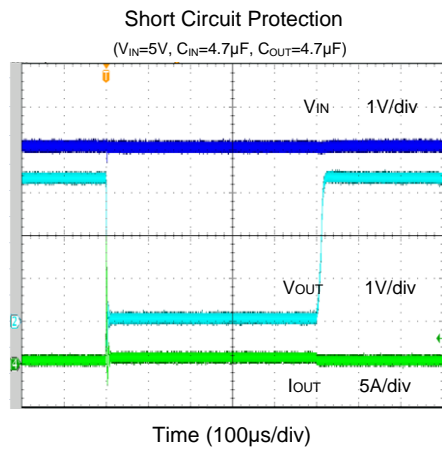
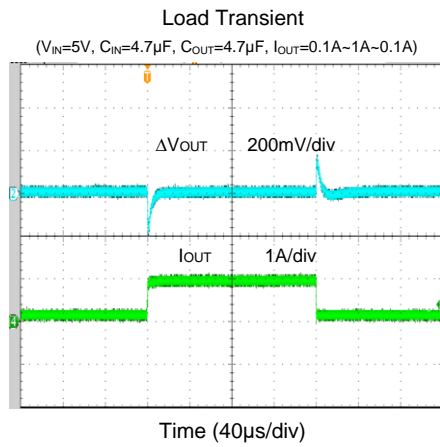
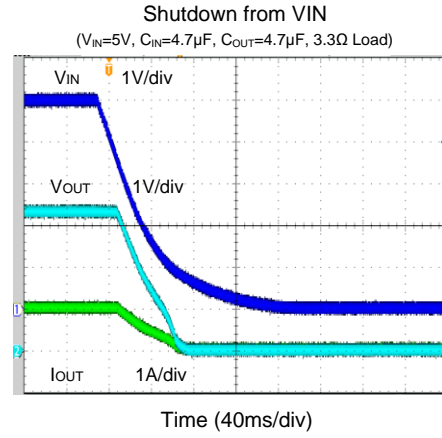
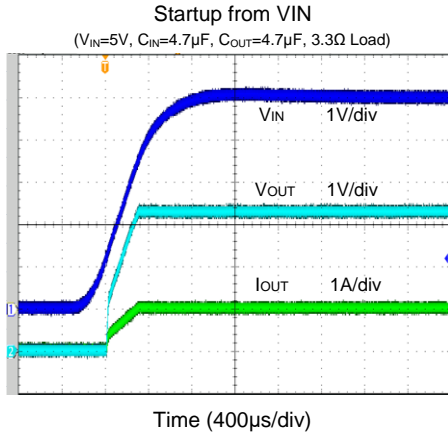

## Operation

The SY6301B is a super low dropout LDO regulator with 3.3V fixed output voltage, capable of delivering up to 1A output current.

## Applications Information

### Over-Temperature Protection (OTP)

The SY6301B includes over-temperature protection (OTP) circuitry to prevent overheating due to excessive power dissipation. This will turn off the device when the junction temperature exceeds 150°C. Once the junction temperature cools down by approximately 20°C the device will resume normal operation.

### Over Current Protect

The minimum current limit is 1A. When the over current condition is sensed, the gate of the pass switch is modulated to achieve constant output current. If the over current condition persists for a long time, the junction temperature may exceed 150°C, and over-temperature protection will shut down the part. Once the chip temperature drops below 130°C, the part will restart.

### Input Capacitor $C_{IN}$

To minimize the potential noise problem and improve power-supply rejection(PSRR) and transient response, place a typical X5R or better grade ceramic capacitor really close to the IN and GND pins. Care should be taken to minimize the loop area formed by  $C_{IN}$ , and IN/GND pins. In this case, a 4.7 $\mu$ F low ESR ceramic capacitor is recommended.

### Output Capacitor $C_{OUT}$

For stable operation over the full temperature range, a 4.7 $\mu$ F low-ESR ceramic capacitor is recommended. Use larger output-capacitor values such as 10 $\mu$ F to reduce noise, improve load-transient response and PSRR.

### PCB Layout Guide

For best performance of the SY6301B, the following guidelines must be strictly followed:

1. Keep all power trace as short and wide as possible.
2. Place input/output capacitor close to the IC for better transient performance.

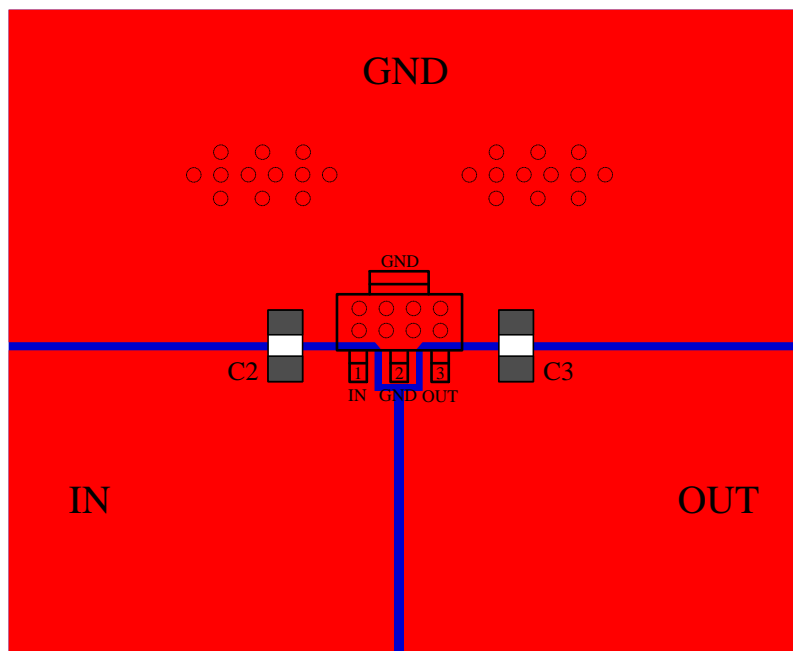
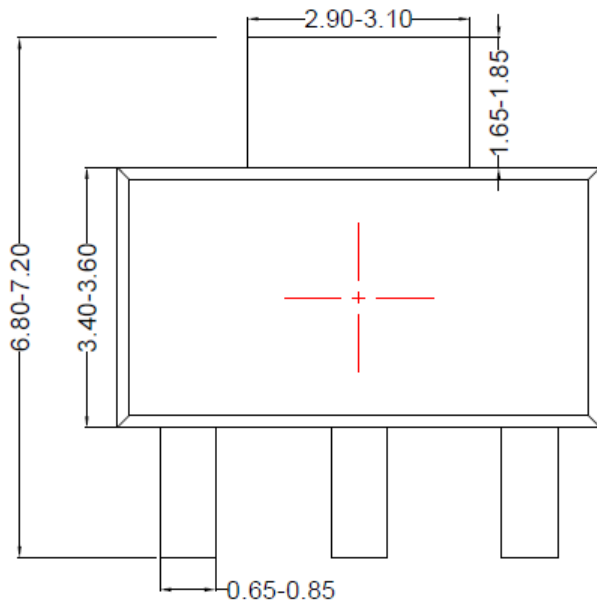
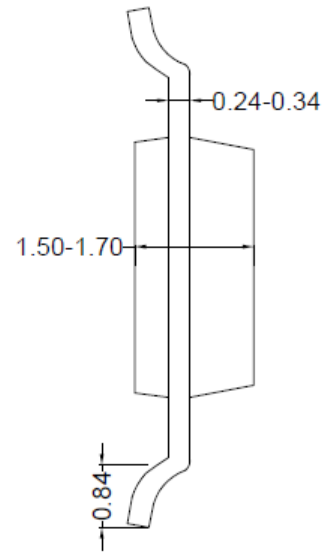

Figure3. SY6301B PCB Layout Suggestion

**SOT223 Package Outline Drawing**



**Top View**



**Bottom View**

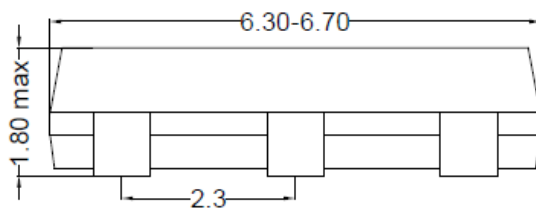

**Front View**

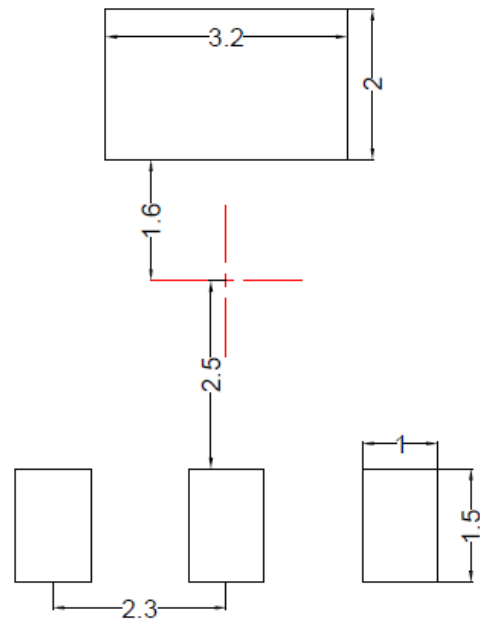

**Recommended PCB layout  
(Reference only)**

**Notes: 1, All dimension in millimeter and exclude mold flash & metal burr;  
2, center line on drawing refers to the chip body center**

## Taping & Reel Specification

### 1. Taping Orientation

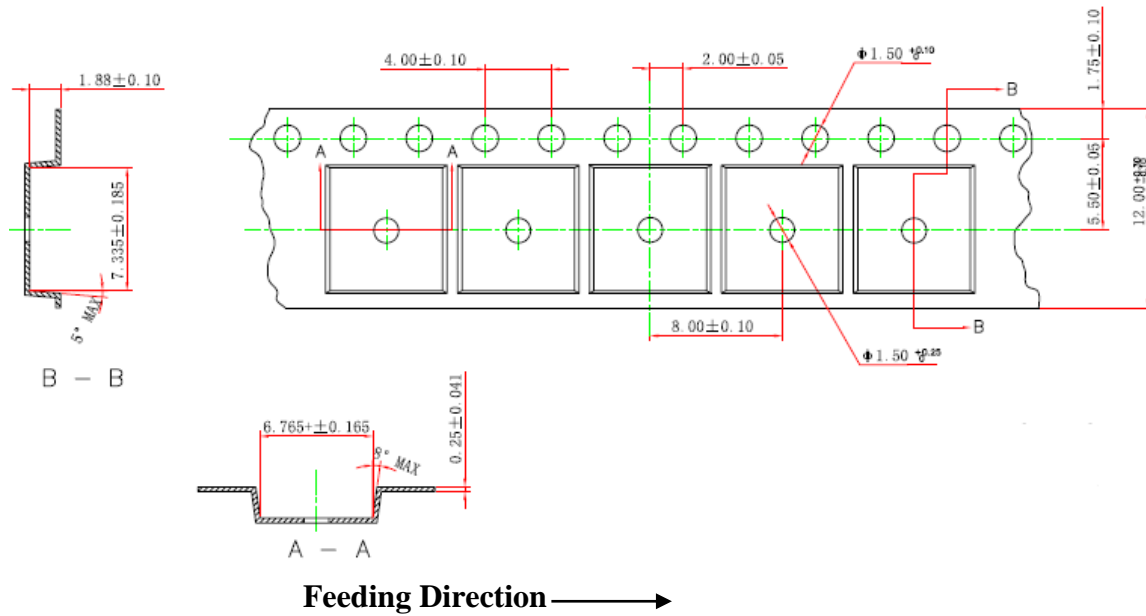

### 2. Carrier Tape & Reel specification for packages

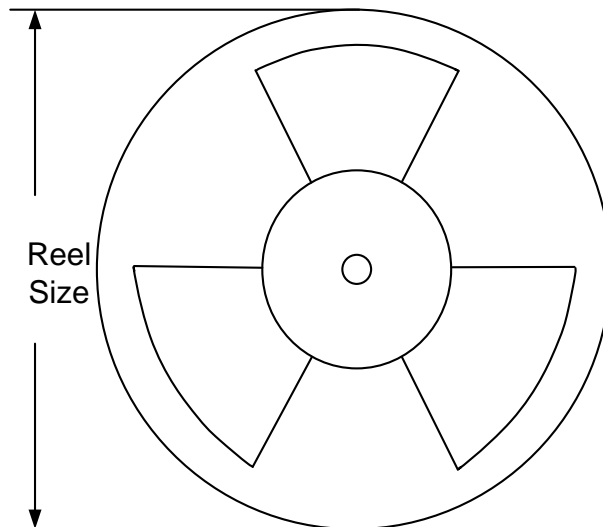

Package type	Tape width (mm)	Pocket pitch(mm)	Reel size (Inch)	Trailer * length(mm)	Leader * length (mm)	Qty per reel
						(pcs)
SOT223	12	8	13"	400	400	2500

### 3. Others: NA

**IMPORTANT NOTICE**

- 1. Right to make changes.** Silergy and its subsidiaries (hereafter Silergy) reserve the right to change any information published in this document, including but not limited to circuitry, specification and/or product design, manufacturing or descriptions, at any time and without notice. This document supersedes and replaces all information supplied prior to the publication hereof. Buyers should obtain the latest relevant information before placing orders and should verify that such information is current and complete. All semiconductor products are sold subject to Silergy's standard terms and conditions of sale.
- 2. Applications.** Application examples that are described herein for any of these products are for illustrative purposes only. Silergy makes no representation or warranty that such applications will be suitable for the specified use without further testing or modification. Buyers are responsible for the design and operation of their applications and products using Silergy products. Silergy or its subsidiaries assume no liability for any application assistance or designs of customer products. It is customer's sole responsibility to determine whether the Silergy product is suitable and fit for the customer's applications and products planned. To minimize the risks associated with customer's products and applications, customer should provide adequate design and operating safeguards. Customer represents and agrees that it has all the necessary expertise to create and implement safeguards which anticipate dangerous consequences of failures, monitor failures and their consequences, lessen the likelihood of failures that might cause harm and take appropriate remedial actions. Silergy assumes no liability related to any default, damage, costs or problem in the customer's applications or products, or the application or use by customer's third-party buyers. Customer will fully indemnify Silergy, its subsidiaries, and their representatives against any damages arising out of the use of any Silergy components in safety-critical applications. It is also buyers' sole responsibility to warrant and guarantee that any intellectual property rights of a third party are not infringed upon when integrating Silergy products into any application. Silergy assumes no responsibility for any said applications or for any use of any circuitry other than circuitry entirely embodied in a Silergy product.
- 3. Limited warranty and liability.** Information furnished by Silergy in this document is believed to be accurate and reliable. However, Silergy makes no representation or warranty, expressed or implied, as to the accuracy or completeness of such information and shall have no liability for the consequences of use of such information. In no event shall Silergy be liable for any indirect, incidental, punitive, special or consequential damages, including but not limited to lost profits, lost savings, business interruption, costs related to the removal or replacement of any products or rework charges, whether or not such damages are based on tort or negligence, warranty, breach of contract or any other legal theory. Notwithstanding any damages that customer might incur for any reason whatsoever, Silergy' aggregate and cumulative liability towards customer for the products described herein shall be limited in accordance with the Standard Terms and Conditions of Sale of Silergy.
- 4. Suitability for use.** Customer acknowledges and agrees that it is solely responsible for compliance with all legal, regulatory and safety-related requirements concerning its products, and any use of Silergy components in its applications, notwithstanding any applications-related information or support that may be provided by Silergy. Silergy products are not designed, authorized or warranted to be suitable for use in life support, life-critical or safety-critical systems or equipment, nor in applications where failure or malfunction of an Silergy product can reasonably be expected to result in personal injury, death or severe property or environmental damage. Silergy assumes no liability for inclusion and/or use of Silergy products in such equipment or applications and therefore such inclusion and/or use is at the customer's own risk.
- 5. Terms and conditions of commercial sale.** Silergy products are sold subject to the standard terms and conditions of commercial sale, as published at <http://www.silergy.com/stdterms>, unless otherwise agreed in a valid written individual agreement specifically agreed to in writing by an authorized officer of Silergy. In case an individual agreement is concluded only the terms and conditions of the respective agreement shall apply. Silergy hereby expressly objects to and denies the application of any customer's general terms and conditions with regard to the purchase of Silergy products by the customer.
- 6. No offer to sell or license.** Nothing in this document may be interpreted or construed as an offer to sell products that is open for acceptance or the grant, conveyance or implication of any license under any copyrights, patents or other industrial or intellectual property rights. Silergy makes no representation or warranty that any license, either express or implied, is granted under any patent right, copyright, mask work right, or other intellectual property right. Information published by Silergy regarding third-party products or services does not constitute a license to use such products or services or a warranty or endorsement thereof. Use of such information may require a license from a third party under the patents or other intellectual property of the third party, or a license from Silergy under the patents or other intellectual property of Silergy.

For more information, please visit: [www.silergy.com](http://www.silergy.com)

© 2019 Silergy Corp.

**All Rights Reserved.**