

### General Description

The SY6040 is a stereo headphone/lineout driver designed to allow the removal of the output DC blocking capacitors for reducing the component counts and the cost. It is composed of a LDO and a charge pump. The SY6040 is an ideal choice for small portable electronics where size and cost are critical design parameters. The SY6040 is capable of driving 21mW into a 32Ω load at 3.3V when  $R_S=47\Omega$ . The gain of SY6040 is set by the Gain Control pin. The charge pump and the headphone power are supplied by the LDO.

### Ordering Information

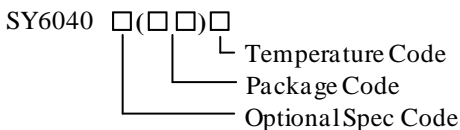

Ordering Number	Package Type	Note
SY6040QDC	QFN3×3-16	----

### Features

- 21mW/Ch Output Power into 32Ω Load at 3.3V When  $R_S=47\Omega$
- 86mW/Ch Output Power into 32Ω Load at 3.3V When  $R_S=0\Omega$
- Wide Power Supply Range: 2.2V-5.5V
- Ground Referenced Outputs Eliminate the DC Bias Voltage on the Headphone Ground Pin
- No Output DC Blocking Capacitors
- Reduced Board Area
- Reduced Component Cost
- Improved THD+N Performance
- No Degradation of the Low Frequency Response Due to the Output Capacitors
- Built in the LDO and the Charge Pump
- Short Circuit Protection, Thermal Protection and Under Voltage Protection
- Click and Pop Suppression Circuit
- Surface Mount, QFN, 16 Pin, 3mm×3mm

### Applications

- Notebook Computers
- CD/MP3 Player
- Smart Phones
- Cellular Phones
- PDA

### Typical Application

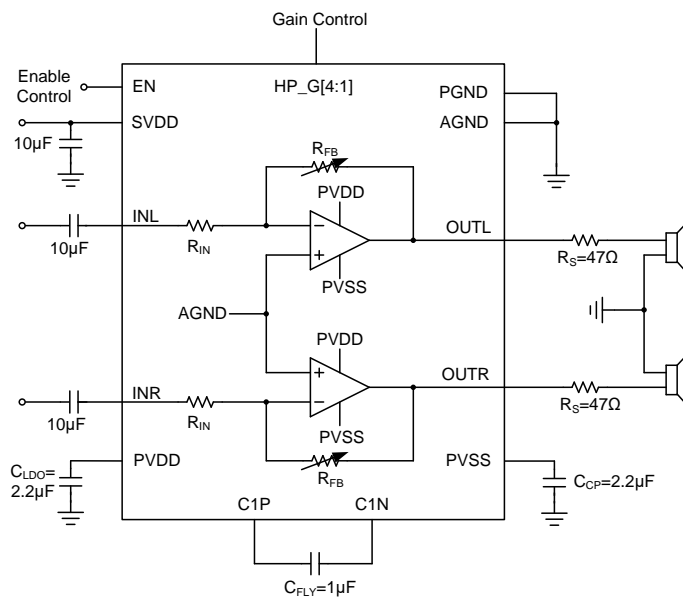
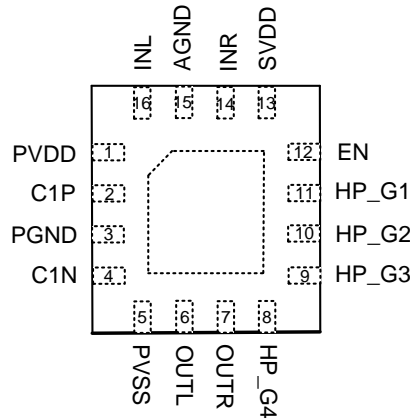

Figure1. Typical Application

**Pinout (Top View)**



(QFN3x3-16)

**Top Mark: cBxyz** (device code: cB, x=year code, y=week code, z= lot number code)

Pin Name	Pin Number	Description
PVDD	1	LDO output / HP-amp positive supply.
C1P	2	Charge pump flying capacitor positive terminal.
PGND	3	Power ground (connected to GND).
C1N	4	Charge pump flying capacitor negative terminal.
PVSS	5	Output from negative Charge Pump / HP-amp negative supply.
OUTL	6	Left audio channel output signal.
OUTR	7	Right audio channel output signal.
HP_G4	8	Gain control.
HP_G3	9	Gain control.
HP_G2	10	Gain control.
HP_G1	11	Gain control.
EN	12	Enable pin, active high logic.
SVDD	13	Supply voltage.
INR	14	Right audio channel input signal.
AGND	15	Analog ground (connect to GND).
INL	16	Left audio channel input signal.

**Block Diagram**

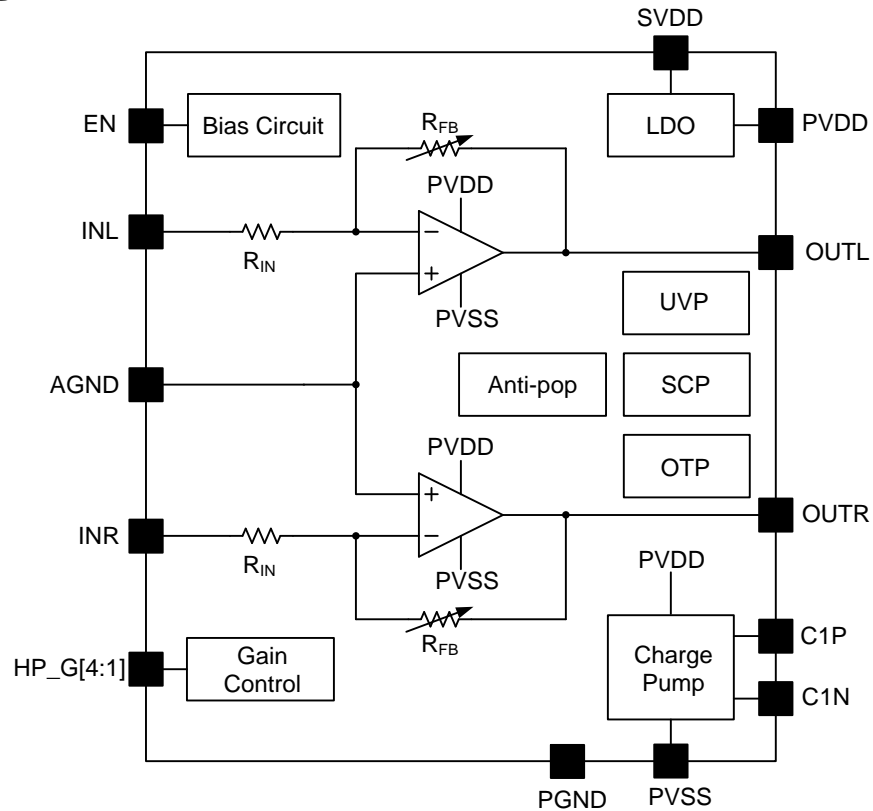

**Figure2. Block Diagram**

**Absolute Maximum Ratings** (Note 1)

Supply Voltage Range (SVDD)	-----	-0.3V to 6V
Input Voltage	-----	-0.3V to (SVDD+0.3)V
Junction Temperature Range	-----	-40°C to 150°C
Storage Temperature Range	-----	-40°C to 125°C

**Recommended Operating Conditions**

Supply Voltage Range	-----	2.2V to 5.5V
Junction Temperature Range	-----	-40°C to 125°C
Ambient Temperature Range	-----	-40°C to 85°C

## Electrical Characteristics

( $T_A=25^\circ\text{C}$ ,  $\text{SVDD}=3.3\text{V}$ ,  $\text{Gain}=6\text{dB}$ ,  $R_S=47\Omega$ ,  $R_L=32\Omega$ , unless otherwise specified.)

Parameter	Symbol	Test Conditions	Min	Typ	Max	Unit
<b>DC Characteristics</b>						
Quiescent Supply Current	$I_Q$	EN=1, no load (Note 2)		9.5		mA
		EN=1, no load, $V_{DD}=2.4\text{V}$ (Note 2)		7.2		mA
		EN=1, no load, $V_{DD}=5\text{V}$ (Note 2)		9.6		mA
		EN=0, no load		0.5	1	$\mu\text{A}$
High-level Input Voltage	$V_{IH}$	EN, HP_G1, HP_G2, HP_G3, HP_G4	1.2			V
Low-level Input Voltage	$V_{IL}$	EN, HP_G1, HP_G2, HP_G3, HP_G4			0.45	V
High-level Input Current	$ I_{IH} $	EN, HP_G1, HP_G2, HP_G3, HP_G4, $\text{SVDD}=5\text{V}$ , $V_I=5\text{V}$		0.1	1	$\mu\text{A}$
Low-level Input Current	$ I_{IL} $	EN, HP_G1, HP_G2, HP_G3, HP_G4, $\text{SVDD}=5\text{V}$ , $V_I=0\text{V}$		0.1	1	$\mu\text{A}$
High-level Output Voltage (Note 2)	$V_{OH}$	Gain=0dB, $V_I=-3.3\text{V}$		3		V
		Gain=0dB, $R_L=10\text{k}\Omega$ , $V_I=-3.3\text{V}$		3.25		V
Low-level Output Voltage (Note 2)	$V_{OL}$	Gain=0dB, $V_I=3.3\text{V}$		-2.8		V
		Gain=0dB, $R_L=10\text{k}\Omega$ , $V_I=3.3\text{V}$		-3.25		V
Gain	$A_v$	HP_G[4:1]=0, no load	-0.5	0	0.5	dB
		HP_G[4:1]=2, no load	5.5	6	6.5	
		HP_G[4:1]=15, no load	18.5	19	19.5	
Gain Matching	$\Delta A_v$	HP_G[4:1]=0, no load	-1		1	%
		HP_G[4:1]=2, no load	-1		1	
		HP_G[4:1]=15, no load	-1		1	
Output Offset Voltage	$ V_{OS} $	$V_I=0\text{V}$		1	10	mV
LDO Output Voltage	PVDD	No load	3.05	3.25		V
Charge Pump Output Voltage	PVSS	No load		-3.2	-2.95	V
Charge Pump Switching Frequency	$f_{osc}$		750	1000	1350	kHz
Input Impedance (Note 2)				20		$\text{k}\Omega$
Turn-on Time (Note 2)	$t_{ON}$	EN=1		1.5		ms
Turn-off Time (Note 2)	$t_{OFF}$	EN=0		15		$\mu\text{s}$

AC Characteristics (Note 2)						
Output Power	P <sub>O</sub>	1% THD+N, f=1kHz		21		mW
		1% THD+N, f=1kHz, V <sub>DD</sub> =5V		22		
		1% THD+N, f=1kHz, R <sub>L</sub> =16Ω		16		
		1% THD+N, f=1kHz, R <sub>S</sub> =0Ω (Note 3)		86		
		1% THD+N, f=1kHz, V <sub>DD</sub> =5V, R <sub>S</sub> =0Ω (Note 3)		89		
		1% THD+N, f=1kHz, R <sub>L</sub> =16Ω, R <sub>S</sub> =0Ω (Note 3)		98		
Signal to Noise Ratio	SNR	10mW output, f=1kHz, A-weighted		103		dB
		Max output at THD+N<1%, f=1kHz, A-weighted		106		
		2V <sub>rms</sub> output, f=1kHz, R <sub>L</sub> =47kΩ, A-weighted		107		
		Max output at THD+N<1%, f=1kHz, R <sub>L</sub> =47kΩ, A-weighted		109		
Total Harmonic Distortion +Noise	THD+N	P <sub>O</sub> =10mW, f=1kHz		0.015		%
		P <sub>O</sub> =10mW, f=20Hz		0.01		
		V <sub>O</sub> =2V <sub>rms</sub> , f=1kHz, R <sub>L</sub> =47kΩ		0.007		
Output Integrated Noise	V <sub>n</sub>	20Hz to 22kHz, A-weighted filter, Gain=0dB		2.7		μV
Crosstalk	CT	P <sub>O</sub> =10mW, f=1kHz		-90		dB
		V <sub>O</sub> =2V <sub>rms</sub> , f=1kHz, R <sub>L</sub> =47kΩ		-90		dB
Power Supply Rejection Ratio	PSRR	200mV <sub>pp</sub> ripple, f=1kHz		-83		dB
Shutdown Attenuation		EN=0, reference to P <sub>O</sub> =10mW f=1kHz		-130		dBr
Slew Rate	SR	Gain=0dB, V <sub>I</sub> =3V pulse		3		V/μs
Protection						
Under Voltage Protection	V <sub>UVP</sub>	V <sub>DD</sub> rising		2	2.2	V
		V <sub>DD</sub> falling	1.65	1.85		V
Short Circuit Protection Current Limit (Note 2)	I <sub>sc</sub>	Short to SVDD		300		mA
		Short to GND		200		mA
Thermal Shutdown Temperature (Note 2)	T <sub>SD</sub>	Threshold		155		°C
		Hysteresis		30		°C

**Note 1:** Stresses beyond the “Absolute Maximum Ratings” may cause permanent damage to the device. These are stress ratings only. Functional operation of the device at these or any other conditions beyond those indicated in the operational sections of the specification is not implied. Exposure to absolute maximum rating conditions for extended periods may affect device reliability.

**Note 2:** Typical test value on the demonstration board (C<sub>LDO</sub>=2.2μF, C<sub>FLY</sub>=1μF, C<sub>CP</sub>=2.2μF), guaranteed by design.

**Note 3:** For R<sub>S</sub>=0Ω application, the output capacitor is 220pF on the demonstration board.

## Typical Performance Characteristics

(All Measurements taken at  $C_{LDO}=2.2\mu F$ ,  $C_{FLY}=1\mu F$ ,  $C_{CP}=2.2\mu F$ ,  $f=1\text{ kHz}$ , Gain=6dB, unless otherwise noted.)

### Headphone

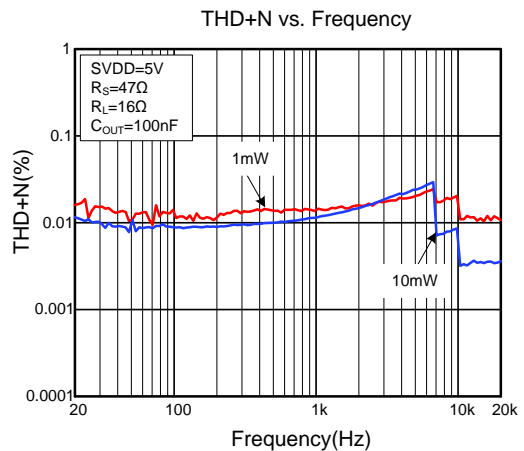
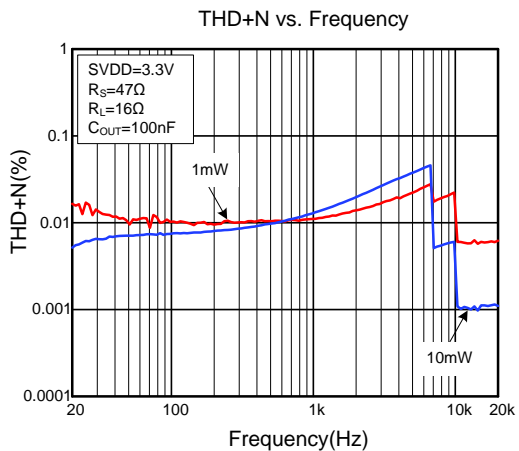
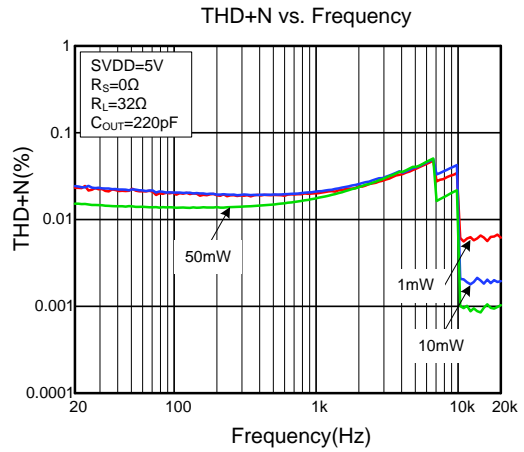
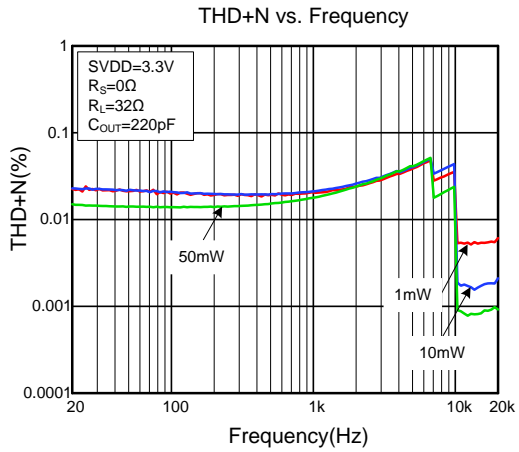
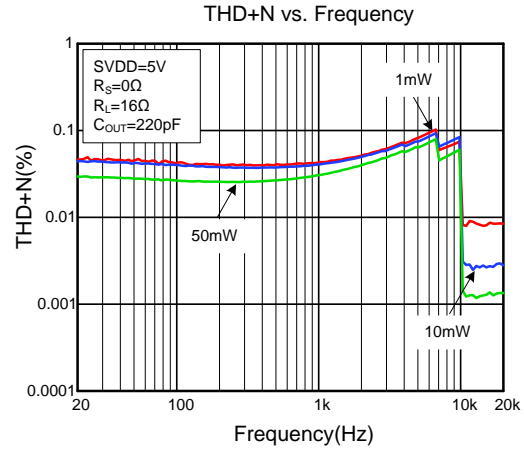
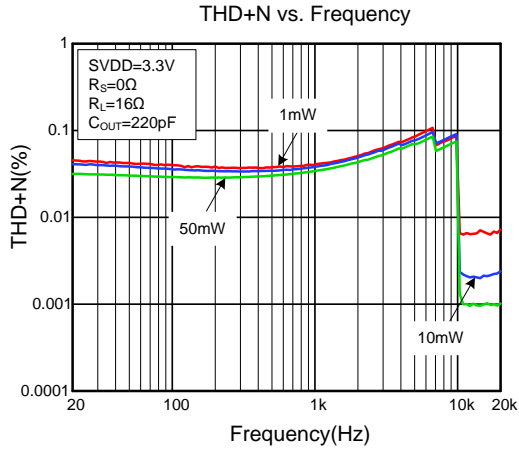

THD+N vs. Frequency

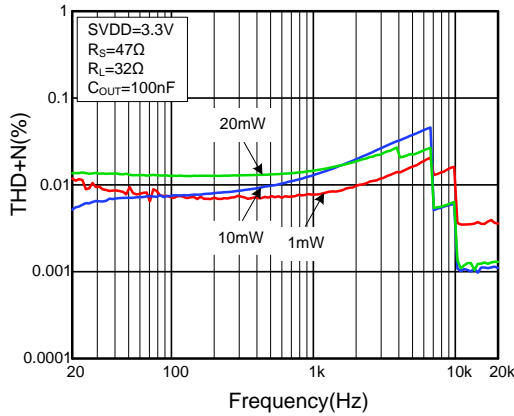

THD+N vs. Frequency

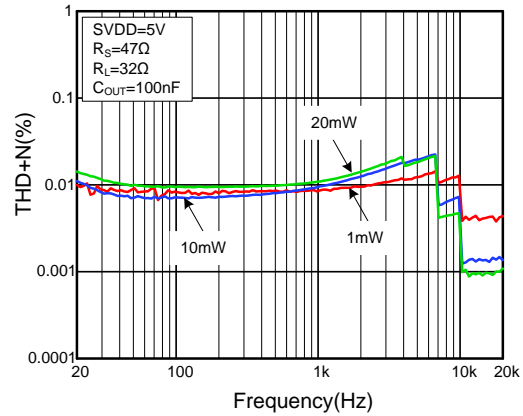

THD+N vs. Output Power

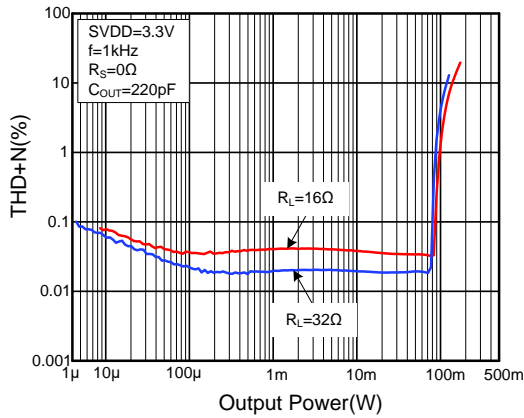

THD+N vs. Output Power

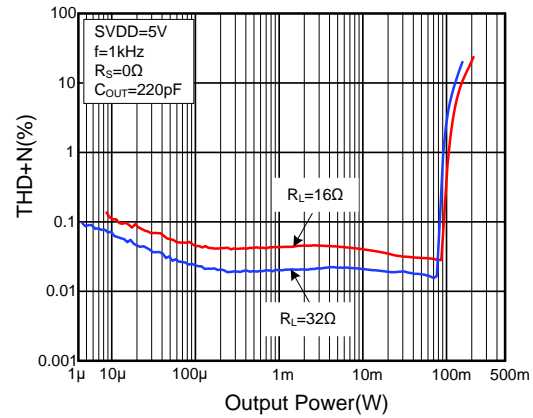

THD+N vs. Output Power

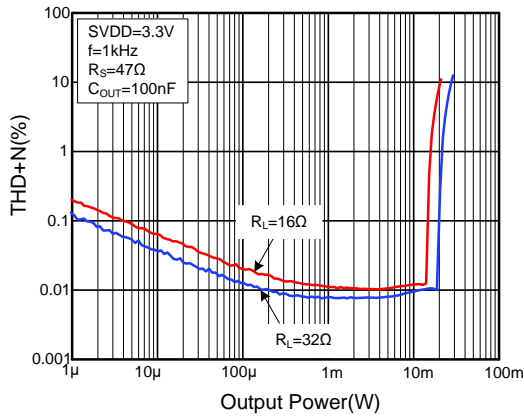

THD+N vs. Output Power

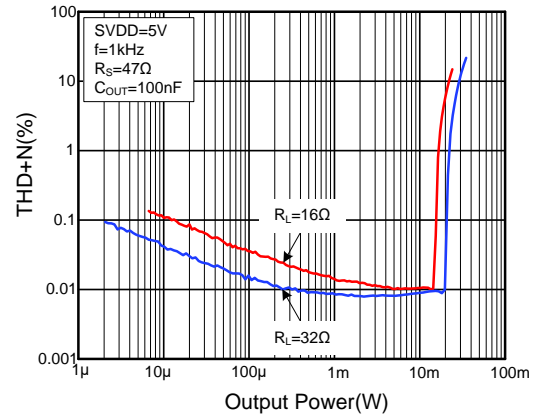

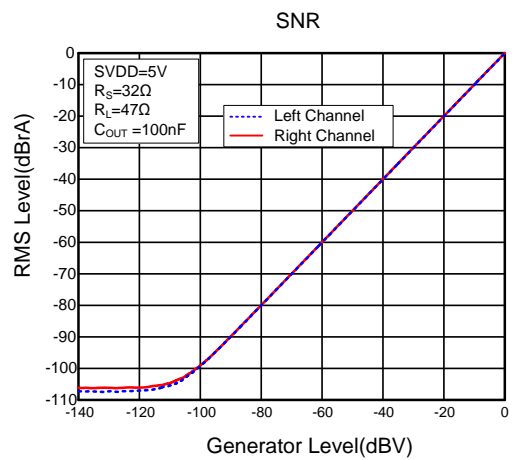
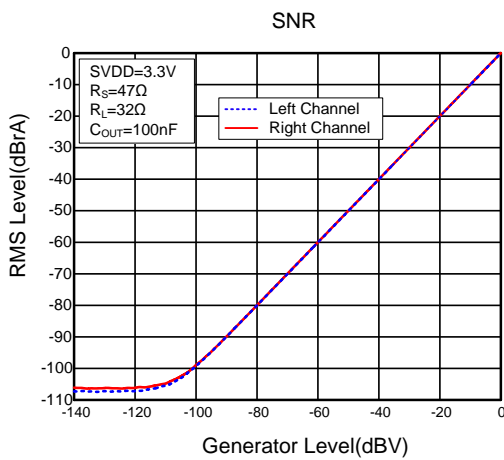
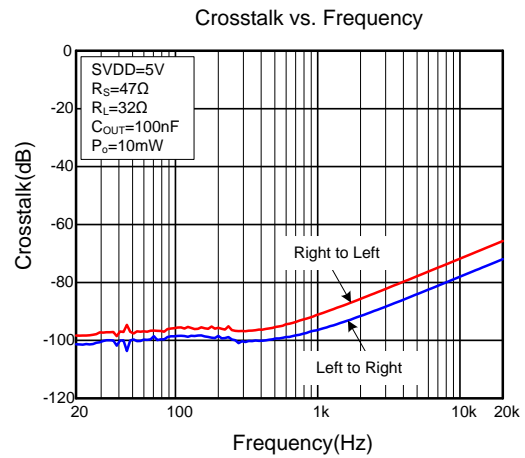
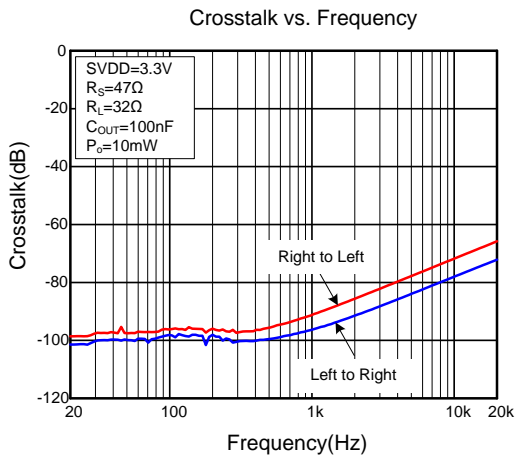
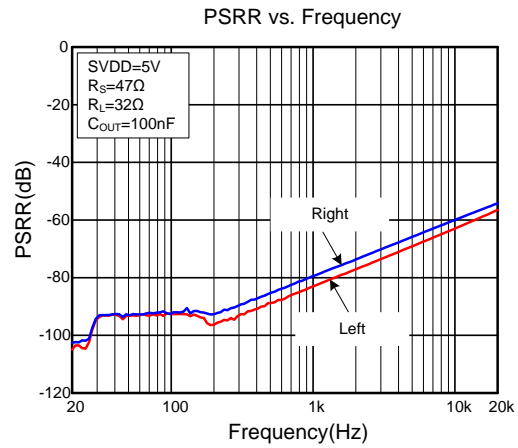
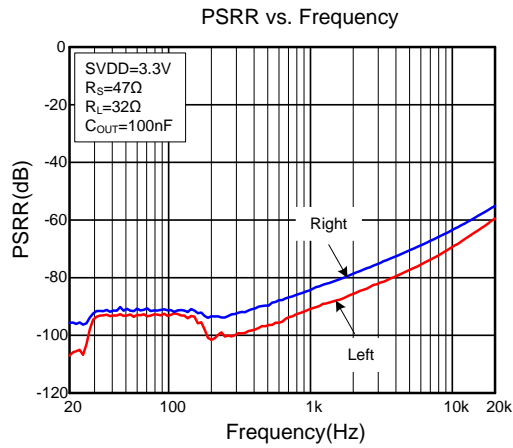

**Line Out**

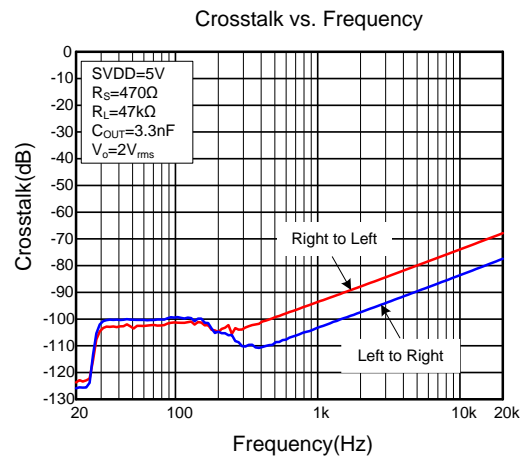
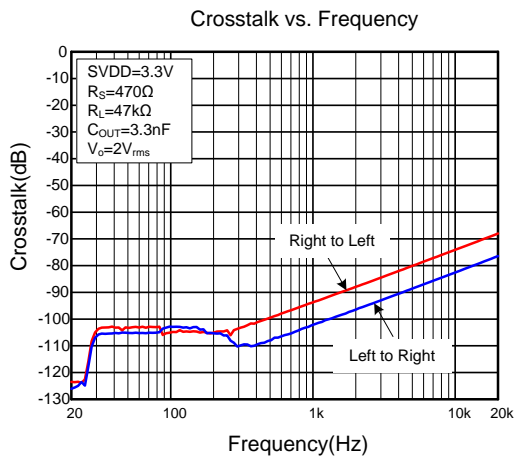
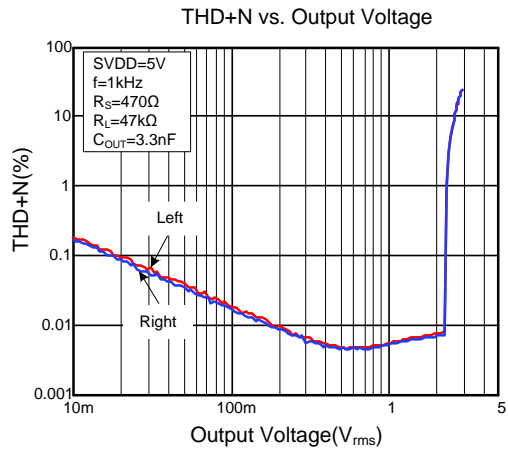
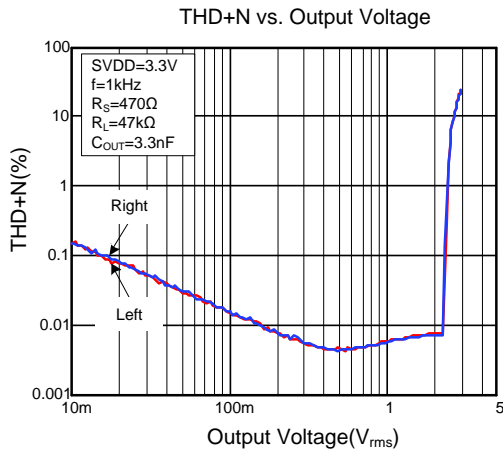
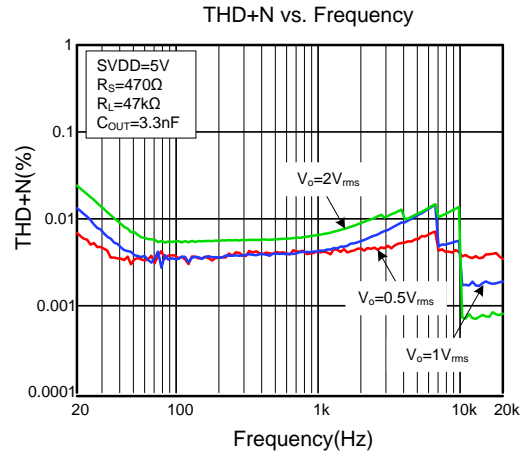
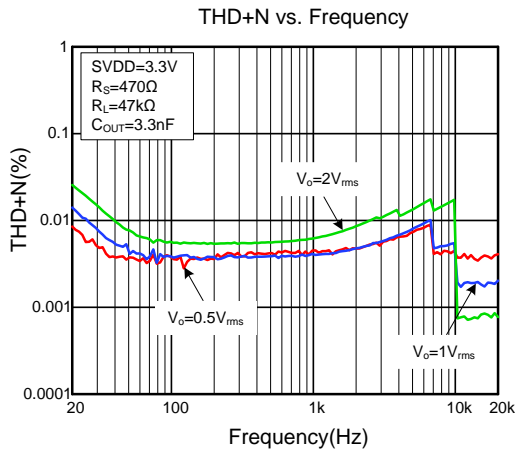

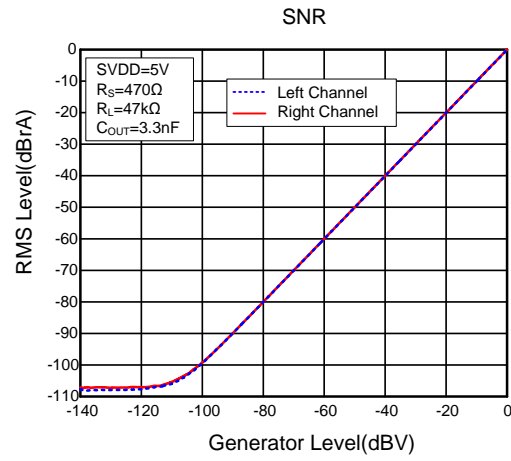
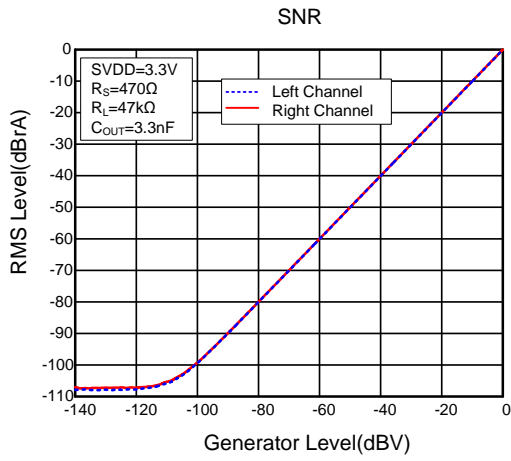

## Function Description

This section focuses on the description of the SY6040 capacitor-less headphone/lineout driver function block operation.

### Capacitor-less Headphone Amplifier

Single-supply headphone amplifiers typically require DC-blocking capacitors. The capacitors are required because most headphone amplifiers have a DC bias on the output pin. If the DC bias is not removed, the power consumption will be higher, the large DC current will rush through the headphones and potentially damage them. The top drawing in Figure 3 illustrates the conventional headphone amplifier connection.

The DC blocking capacitors are always large in value. The headphone speakers (typical resistive values of 16Ω or 32Ω) combine with the DC blocking capacitors to form a high-pass filter. The -3dB frequency of the filter is very low, so the capacitor must have a large value because the load resistance is small. The large capacitance values require large package sizes. The large package sizes consume the PCB area, stand high above the PCB and increase the cost of assembly, which will reduce the fidelity of the audio output signal.

The capacitor-less amplifier architecture operates from a single supply but uses an internal charge pump to provide a negative voltage rail. Combining the positive rail provided by the LDO and the negative rail generated by the charge pump, the device operates in an effective split supply mode. The output voltages are centered at 0V now with the capability to swing to the positive rail or the negative rail. The capacitor-less amplifier requires no output DC blocking capacitors. It does not place any voltage on the sleeve. The bottom block diagram and the waveform of Figure 3 illustrate the ground-referenced headphone architecture. This is the architecture of the SY6040.

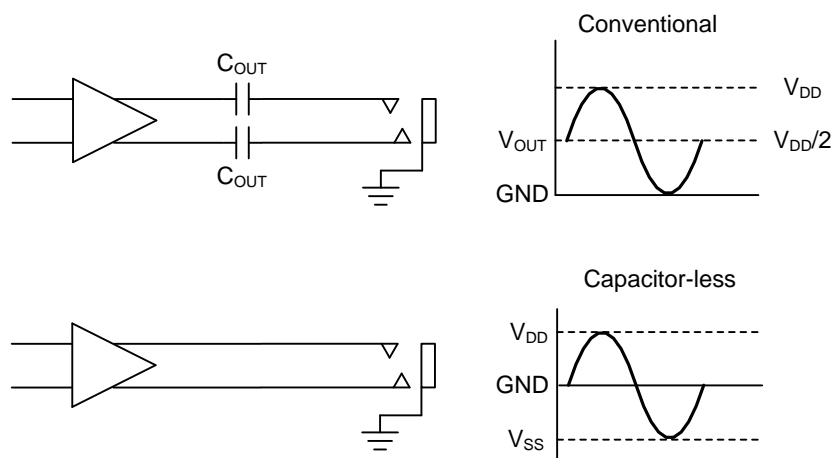

**Figure3. Amplifier Application**

### Lineout Amplifier

The SY6040 can be used as an audio lineout driver capable of providing 2.0V<sub>rms</sub> into 47kΩ loads with the single supply of 3.3V.

### Modes of Operation

The SY6040 supports two modes of operation. When the EN pin is driven to low, the device will be in low power mode with the LDO and the charge pump powered down, the audio channels disabled and the outputs pulled to the ground. When the EN pin is driven to high, the device will enter active mode with the LDO and the charge pump powered up and the audio channels enabled. The transition from inactive to active state and active to inactive state is done softly through the anti-pop process to avoid the audible artifacts.

### Gain Setting

The gain of the SY6040 is programmed by the Gain Control pin as Table 1.

Number	HP_G1	HP_G2	HP_G3	HP_G4	dB
1	0	0	0	0	0
2	0	0	0	1	5
3	0	0	1	0	6
4	0	0	1	1	7
5	0	1	0	0	8
6	0	1	0	1	9
7	0	1	1	0	10
8	0	1	1	1	11
9	1	0	0	0	12
10	1	0	0	1	13
11	1	0	1	0	14
12	1	0	1	1	15
13	1	1	0	0	16
14	1	1	0	1	17
15	1	1	1	0	18
16	1	1	1	1	19

**Table1. Gain Set Table**

### Input-blocking Capacitor

The input capacitor  $C_{IN}$  is required to allow the amplifier to bias the input signal to the proper DC level for optimum operation. The input resistance  $R_{IN}$  of the SY6040 remains a constant value  $20k\Omega$  with the change of the gain. In this case,  $C_{IN}$  and  $R_{IN}$  will compose a high-pass filter with the cutoff frequency determined in the following equation:

$$f_c(\text{highpass}) = \frac{1}{2\pi R_{IN} C_{IN}}$$

The value of  $C_{IN}$  is important to consider carefully because it directly affects the low frequency THD performance and the pop noise of the circuit.

### LDO Output Capacitor

The SY6040 uses the LDO to generate the positive voltage PVDD to supply the amplifier. The LDO needs an output capacitor to be stable and reduces the output voltage ripple. Using a low-ESR ceramic capacitor greater than  $2.2\mu F$  is recommended.

### Charge Pump Flying Capacitor

The SY6040 uses the charge pump to generate the negative voltage PVSS to supply the amplifier. The charge pump flying capacitor  $C_{FLY}$  serves to transfer the charge during the generation of the negative supply voltage as Figure 4. It affects the load transient of the charge pump. If the capacitor's value is too small, it will increase the charge pump's output resistance and degrade the performance of the headphone amplifier. It is recommended to use the low ESR ceramic capacitor with a typical value of  $1\mu F$ .

### Charge Pump Output Capacitor

The charge pump needs an output capacitor to filter the negative output current pulse flowing into PVSS pin and reduce the output voltage ripple. The PVSS capacitor must be at least equal to the charge pump capacitor in order to allow the maximum charge to transfer. Using a low ESR ceramic capacitor greater than 2.2 $\mu$ F is recommended.

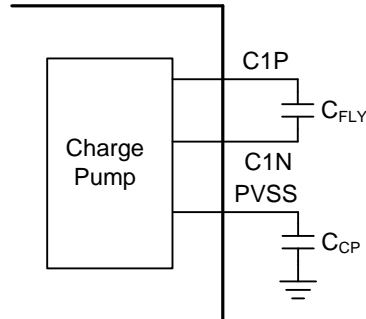

Figure4. Charge Pump Connection

### Power Supply Decoupling Capacitor

The SY6040 is a direct path amplifier that requires adequate power-supply decoupling to ensure that the noise and the THD+N are low. A good low ESR ceramic capacitor, typically 10 $\mu$ F, placed as close as possible to the device SVDD pin works best.

### Under Voltage Protection

If the voltage on the SVDD pin falls below the under voltage threshold 1.85V, the amplifier will be disabled and the internal logic will be reset. The operation will resume when SVDD rises above the UVLO threshold with 0.15V hysteresis.

### Short Circuit Protection

The SY6040 has the protection for short circuit caused by a short from output port to VDD or GND. The current limiting block prevents the output current too high to damage the device.

### Thermal Protection

The thermal protection on the SY6040 will prevent damage to the device when the internal die temperature exceeds 155°C. Once the die temperature exceeds the thermal set point, the device will enter the shutdown state and the outputs will be disabled. This is not a latched fault. The thermal fault will be cleared once the temperature of the die is reduced by 30°C.

### PCB Layout

- 1) All the components should be placed close to the SY6040. The decoupling capacitors should be placed by the power pin to decouple the power rail noise.
- 2) The input traces should be short and symmetric.
- 3) The output traces should be short, wide, and symmetric.
- 4) The power traces width should be greater than 50mil.
- 5) The ground traces are recommended to be routed as a star ground to minimize the interference.
- 6) The QFN thermal PAD should be soldered on the PCB.

**QFN3×3-16 Package Outline & PCB Layout**

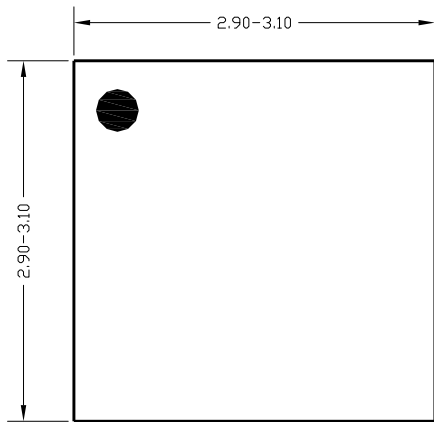

**Top View**

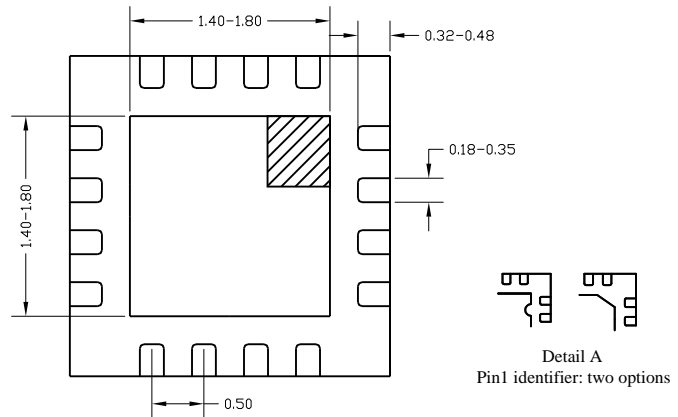

**Bottom View**

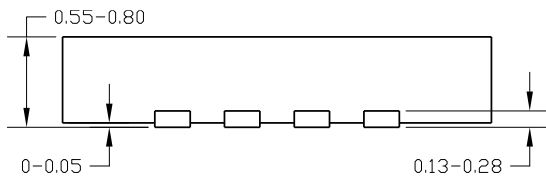

**Front View**

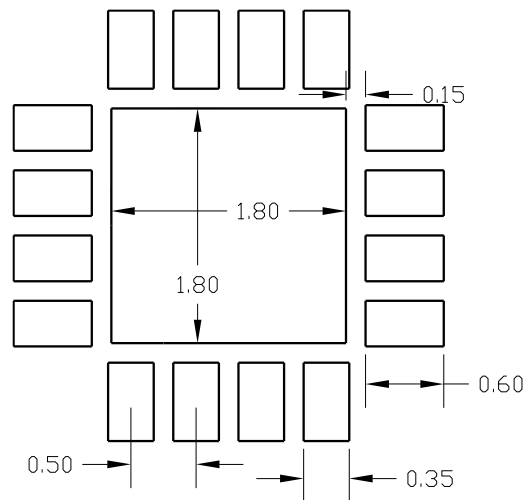

**PCB layout (Recommended)**

**Notes: All dimension in millimeter and exclude mold flash & metal burr.**

## Taping & Reel Specification

### 1. QFN3×3-16 taping orientation

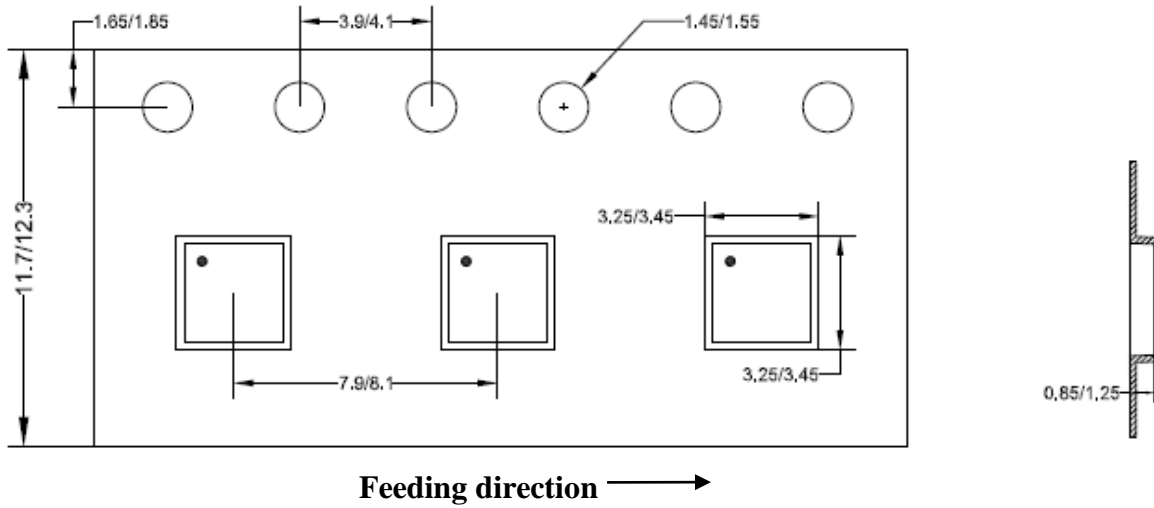

### 2. Carrier Tape & Reel specification for packages

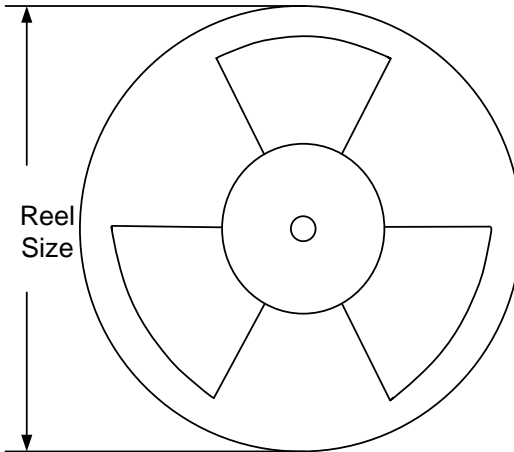

Package types	Tape width (mm)	Pocket pitch(mm)	Reel size (Inch)	Trailer length(mm)	Leader length (mm)	Qty per reel
QFN3×3	12	8	13"	400	400	5000

### 3. Others: NA



### **Revision History**

The revision history provided is for informational purposes only and is believed to be accurate; however, not warranted. Please make sure that you have the latest revision.

<b>Revision Number</b>	<b>Revision Date</b>	<b>Description</b>
Rev 0.9	Oct 22, 2018	Initial Release
Rev 1.0	Oct 22, 2019	Production Release

## IMPORTANT NOTICE

- 1. Right to make changes.** Silergy and its subsidiaries (hereafter Silergy) reserve the right to change any information published in this document, including but not limited to circuitry, specification and/or product design, manufacturing or descriptions, at any time and without notice. This document supersedes and replaces all information supplied prior to the publication hereof. Buyers should obtain the latest relevant information before placing orders and should verify that such information is current and complete. All semiconductor products are sold subject to Silergy's standard terms and conditions of sale.
- 2. Applications.** Application examples that are described herein for any of these products are for illustrative purposes only. Silergy makes no representation or warranty that such applications will be suitable for the specified use without further testing or modification. Buyers are responsible for the design and operation of their applications and products using Silergy products. Silergy or its subsidiaries assume no liability for any application assistance or designs of customer products. It is customer's sole responsibility to determine whether the Silergy product is suitable and fit for the customer's applications and products planned. To minimize the risks associated with customer's products and applications, customer should provide adequate design and operating safeguards. Customer represents and agrees that it has all the necessary expertise to create and implement safeguards which anticipate dangerous consequences of failures, monitor failures and their consequences, lessen the likelihood of failures that might cause harm and take appropriate remedial actions. Silergy assumes no liability related to any default, damage, costs or problem in the customer's applications or products, or the application or use by customer's third-party buyers. Customer will fully indemnify Silergy, its subsidiaries, and their representatives against any damages arising out of the use of any Silergy components in safety-critical applications. It is also buyers' sole responsibility to warrant and guarantee that any intellectual property rights of a third party are not infringed upon when integrating Silergy products into any application. Silergy assumes no responsibility for any said applications or for any use of any circuitry other than circuitry entirely embodied in a Silergy product.
- 3. Limited warranty and liability.** Information furnished by Silergy in this document is believed to be accurate and reliable. However, Silergy makes no representation or warranty, expressed or implied, as to the accuracy or completeness of such information and shall have no liability for the consequences of use of such information. In no event shall Silergy be liable for any indirect, incidental, punitive, special or consequential damages, including but not limited to lost profits, lost savings, business interruption, costs related to the removal or replacement of any products or rework charges, whether or not such damages are based on tort or negligence, warranty, breach of contract or any other legal theory. Notwithstanding any damages that customer might incur for any reason whatsoever, Silergy' aggregate and cumulative liability towards customer for the products described herein shall be limited in accordance with the Standard Terms and Conditions of Sale of Silergy.
- 4. Suitability for use.** Customer acknowledges and agrees that it is solely responsible for compliance with all legal, regulatory and safety-related requirements concerning its products, and any use of Silergy components in its applications, notwithstanding any applications-related information or support that may be provided by Silergy. Silergy products are not designed, authorized or warranted to be suitable for use in life support, life-critical or safety-critical systems or equipment, nor in applications where failure or malfunction of an Silergy product can reasonably be expected to result in personal injury, death or severe property or environmental damage. Silergy assumes no liability for inclusion and/or use of Silergy products in such equipment or applications and therefore such inclusion and/or use is at the customer's own risk.
- 5. Terms and conditions of commercial sale.** Silergy products are sold subject to the standard terms and conditions of commercial sale, as published at <http://www.silergy.com/stdterms>, unless otherwise agreed in a valid written individual agreement specifically agreed to in writing by an authorized officer of Silergy. In case an individual agreement is concluded only the terms and conditions of the respective agreement shall apply. Silergy hereby expressly objects to and denies the application of any customer's general terms and conditions with regard to the purchase of Silergy products by the customer.
- 6. No offer to sell or license.** Nothing in this document may be interpreted or construed as an offer to sell products that is open for acceptance or the grant, conveyance or implication of any license under any copyrights, patents or other industrial or intellectual property rights. Silergy makes no representation or warranty that any license, either express or implied, is granted under any patent right, copyright, mask work right, or other intellectual property right. Information published by Silergy regarding third-party products or services does not constitute a license to use such products or services or a warranty or endorsement thereof. Use of such information may require a license from a third party under the patents or other intellectual property of the third party, or a license from Silergy under the patents or other intellectual property of Silergy.

For more information, please visit: [www.silergy.com](http://www.silergy.com)

© 2018 Silergy Corp.

All Rights Reserved.