



# SY3079AS22-J01

## 21-bit Dynamic Range True Ambient Light Sensor with Clear channel and high speed I<sup>2</sup>C interface

### General Description

The SY3079AS22-J01 device, an ambient light sensor (ALS) with clear channel, features high sensitivity, wide dynamic range and fast communication speed through I<sup>2</sup>C interface.

The SY3079AS22-J01 has 2 photodiode arrays. ALS PD is to sense visible light which includes 6 sensitive ranges and Clear PD is to sense visible and infrared which includes 2 sensitive ranges. ALS channel reading (digital count) is proportional to the illuminance regardless of the light sources while Clear channel reading is related to light source due to its full spectrum response; furthermore, no extra data manipulation is required. It also has a built-in circuit to reject the 50Hz/60Hz flicker noise caused by indoor light sources. Due to a well-engineered optical coating on the top of the ALS PD, its spectral response is almost the same as human eye's photopic vision. Thus system can tell the external light source type by checking the ratio of Clear/ALS channel data, then different preset correction coefficient can be chosen to adapt to different light sources.

### Applications

- TV Panel Control
- Smart Phone
- Accessories
- Industrial Control
- Lighting Control

### Features

- *ALS Channel*
  - Output Count Proportional to Lux
  - Indoor Light Source Flicker Noise Rejection
  - Matching Human Eye's Response (Photopic Vision Curve)
  - 6 Selectable Measurement Ranges
  - Finest Resolution: Down to 0.0079 Lux/Count
  - Maximum Detection Range 16512 Lux
- *Clear Channel*
  - Indoor Light Source Flicker Noise Rejection
  - 2 Selectable Measurement Ranges
- *Green Power*
  - Less than 110 $\mu$ A Supply Current
  - Less than 1 $\mu$ A Supply Current When Powered Down
- *Easy to Use*
  - SMBus Compatible I<sup>2</sup>C Interface
  - Temperature Compensation
- *Wide Operating Voltage Range*
  - 1.7V to 3.6V Supply for I<sup>2</sup>C Interface
  - 2.3V to 3.6V Supply for Sensor
- *Wide Operating Temperature Range*
  - -40°C to +85°C Ambient Temperature
- *Package Information*
  - Size: 2.0mm $\times$ 1.5mm $\times$ 0.6mm
  - Type: SMD (Surface Mount Device) BT with Transparent Molding Compound

## Functional Block Diagram

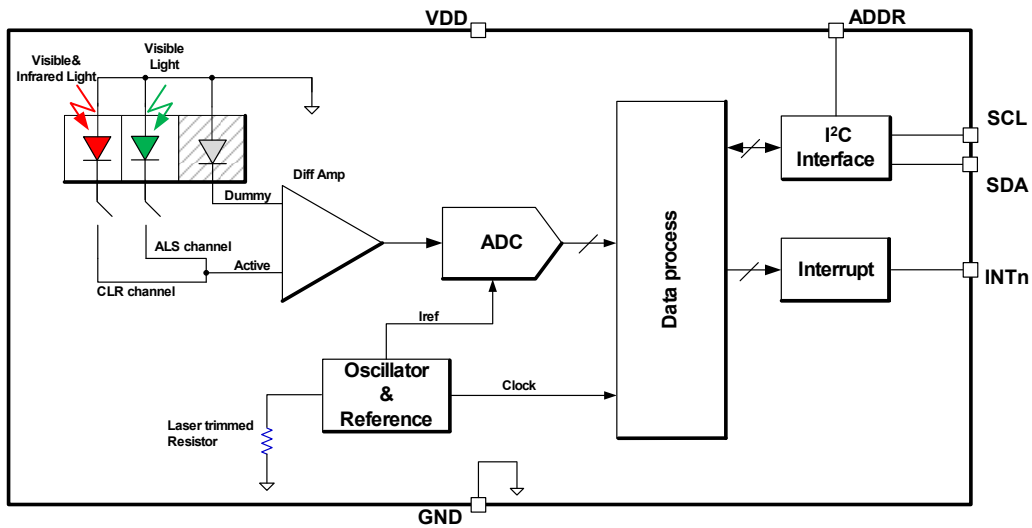

## Pad Descriptions

PIN No	PIN Name	Description
1	ADDR	I <sup>2</sup> C address pin - pulled high for address 0x45, pulled low for address 0x44. Floating is not allowed.
2	VDD	Positive supply: 2.3V to 3.6V
3	GND	Ground pin
4	NC	No connection
5	SCL	I <sup>2</sup> C clock line. The I <sup>2</sup> C bus lines can be pulled from 1.7V to above VDD, 3.6V max
6	SDA	I <sup>2</sup> C data line. The I <sup>2</sup> C bus lines can be pulled from 1.7V to above VDD, 3.6V max
7	INTn	Interrupt output with open-drain configuration, low level active
8	NC	No connection

## Absolute Maximum Ratings <sup>[1]</sup> (T<sub>A</sub> = +25°C)

Symbol	Parameter	Min	Max	Unit
V <sub>DD</sub>	Supply Voltage	-0.3	4.0	V
V <sub>I2C</sub>	I <sup>2</sup> C Bus Voltage	-0.3	4.0	V
I <sub>I2C</sub>	I <sup>2</sup> C Bus Current		10	mA
ESD	Human Body Model	±2000		V
	Charged Device Model	±500		V

### Note

[1]: Stresses beyond the “Absolute Maximum Ratings” may cause permanent damage to the device. These are stress ratings only. Functional operation of the device at these or any other conditions beyond those indicated in the operational sections of the specification is not implied. Exposure to absolute maximum rating conditions for extended periods may affect device reliability.

## Electrical and Optical Characteristics

(The general test conditions are  $V_{DD} = 3.0V$ ,  $T_A = +25^{\circ}C$ )

Parameter	Descriptions	Condition	Min	Typ	Max	Unit
$V_{DD}$	Power supply range		2.3	3.0	3.6	V
$I_{DD\_OFF}$	Supply current when ALS is disabled	ALS_EN = 0			0.1	$\mu A$
$I_{DD\_ONE}$	Supply current for ALS being enabled	ALS_EN =1, Range[2:0] = 3b'0xx	60	90	110	$\mu A$
		ALS_EN =1, Range[2:0] = 3b'1xx	50	80	100	$\mu A$
DATA <sub>ADC_FS</sub>	Full scale output ADC for both channels				65535	counts
RES <sub>finest</sub>	Finest resolution for ALS channel <sup>[1]</sup>	Range[2:0] = 3b'100		0.0079		lux/count
ADC count value ratio: Clear/ALS	White LED, Ev=100lux	Range[2:0]=3b'011 for Clear channel, range[2:0]=3b'000 for ALS channel		0.09		
DATA <sub>DARK</sub>	Dark ADC count	Ev = 0 Lux, Range[2:0] = 3b'000			5	counts
DATA <sub>ALS</sub>	ALS count <sup>[1]</sup> @Ev=100Lux	Range[2:0] = 3b'000	5710	6350	6990	counts

**Note:**

[1]. Fluorescent light (6500K) is used as light source unless otherwise specified. White LED is substituted in mass production

## I<sup>2</sup>C Electrical Specifications

( Unless otherwise specified,  $V_{DD} = 3.0V$ ,  $T_A = +25^{\circ}C$  )

Parameter	Description	Condition	Min	Typ	Max	Unit
$V_{I^2C}$	Supply voltage range for I <sup>2</sup> C interface		1.7	-	$V_{DD}+0.3$	V
$f_{SCL}$	SCL clock frequency		-	-	750	kHz
$V_{IL}$	Low level input voltage of SCL and SDA		-	-	0.55	V
$V_{IH}$	High level input voltage of SCL and SDA		1.25	-	-	V
$V_{hys}$	Hysteresis of schmitt trigger input		-	0.75	-	V
$V_{OL}$	Low-level output voltage (open-drain) at 4mA sink current		-	-	0.4	V
$I_i$	Input leakage for each SDA, SCL		-10	-	10	$\mu A$
$t_{SP}$	Pulse width of spikes that must be suppressed by the input filter		-	-	50	ns
$t_{AA}$	SCL falling edge to SDA output data valid		-	--	0.9	$\mu s$
$C_i$	Capacitance for each SDA and SCL pin		-	-	10	pF
$t_{HD:STA}$	Hold time (repeated) START condition		0.6	-	-	$\mu s$
$t_{LOW}$	Low period of the SCL clock		1.3	-	-	$\mu s$
$t_{HIGH}$	High period of the SCL clock		0.6	-	-	$\mu s$
$t_{SU:STA}$	Set-up time for a repeated START condition		0.6	-	-	$\mu s$
$t_{HD:DAT}$	Data hold time		30	-	-	ns
$t_{SU:DAT}$	Data set-up time		100	-	-	ns
$t_{SU:STO}$	Set-up time for STOP condition		0.6	-	-	$\mu s$
$t_{BUF}$	Bus free time between a STOP and START condition		1.3	-	-	$\mu s$
$t_r$	Rise time of both SDA and SCL	$R_{pull-up} = 10k\Omega$ , $C_b = 10pF$	-	95	-	ns
$t_f$	Fall time of SDA and SCL	$R_{pull-up} = 10k\Omega$ , $C_b = 10pF$	-	25	-	ns
$C_b$	Capacitive load for each bus line		-	-	0.4	nF
$R_{pull-up}$	SDA and SCL system bus pull-up resistor	Maximum is determined by $t_r$ and $t_f$	-	10	-	k $\Omega$
$t_{VD:DAT}$	Data valid time		-	-	0.9	$\mu s$
$t_{VD:ACK}$	Data valid to acknowledge time		-	-	0.9	$\mu s$
$V_{nL}$	Noise margin at the LOW level		0.1 $V_{DD}$	-	-	V
$V_{nH}$	Noise margin at the HIGH level		0.2 $V_{DD}$	-	-	V

Note: The I<sup>2</sup>C bus protocol was developed by Philips (now NXP). For a complete description of the I<sup>2</sup>C protocol, please review the NXP I<sup>2</sup>C design specification at <http://www.i2c-bus.org/references/>.

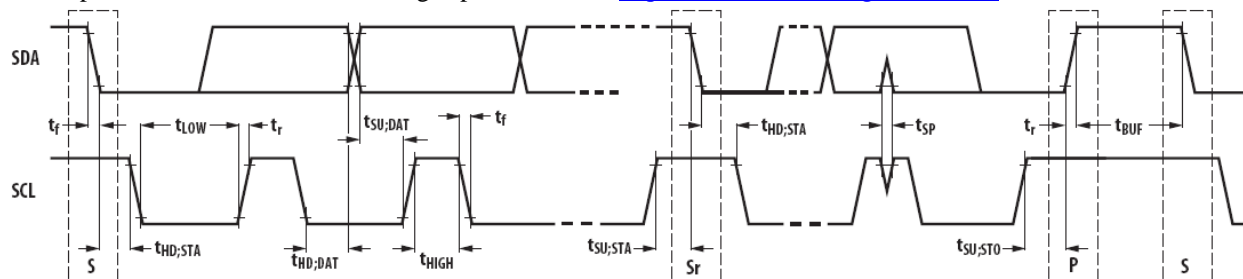

Figure 1. I<sup>2</sup>C Timing Diagram

## Register Map

There are nine 8-bit registers accessible via I<sup>2</sup>C. Register 0x00 has a fixed value 0x21 for communication test. Registers 0x01 and 0x02 configure the device's operation. Registers 0x03 and 0x04 contain the real time ADC data for either ALS or Clear channel. Registers 0x05 through 0x08 store the various thresholds which trigger interrupt events.

Table 1. Registers and register bits

Register Address	Register Name	BIT								DEFAULT
		7	6	5	4	3	2	1	0	
0x00	COM_TEST	READ-ONLY, IC identifier								0x21
0x01	CONFIG1	ALS_EN	(Write 0)			INT_FLAG	PRST[1:0]		0x00	
0x02	CONFIG2	(Write 0)				RANGE[2:0]			0x00	
0x03	ALS_DATA_L	ALS_DATA[7:0]								0x00
0x04	ALS_DATA_H	ALS_DATA[15:8]								0x00
0x05	INT_LTL	INT_LT[7:0]								0x00
0x06	INT_LTH	INT_LT[15:8]								0x00
0x07	INT_HTL	INT_HT[7:0]								0xFF
0x08	INT_HTH	INT_HT[15:8]								0xFF

### Communication Test Register (0x00)

This read-only register contains a fixed data 0x21. Read this register through the I<sup>2</sup>C interface to test whether the communication link is established or not.

Table 2. Register 0x01 (CON1) – Configure registers 1

Bit	Access	Default	Name	Descriptions
7	RW	0x00	ALS_EN	When =0, Power-down mode When =1, Normal operation mode
6:3	RW	0x00	Reserved	Unused register bit- write 0
2	R	0x00	INT_FLAG	When = 0, no interrupt has occurred since power-on or last “clear” When = 1, an interrupt event occurred
1:0	RW	0x00	PRST	For bits 1:0 = (see the following) 00, set INT_FLAG if 1 reading trips the threshold value 01, set INT_FLAG if 4 consecutive readings trip the threshold value 10, set INT_FLAG if 8 consecutive readings trip the threshold value 11, set INT_FLAG if 16 consecutive readings trip the threshold value

Table 3. Register 0x02 (CON2) – Configure register 2

Bit	Access	Default	Name	Descriptions
7:3	R/W	0x00	Reserved	Unused register bit- write 0
2:0	R/W	0x00	RANGE	For bits 2:0 =(see the following) 000, ALS channel detection range is 1032lux; 001, ALS channel detection range is 4128lux; 010, ALS channel detection range is 16512lux; 011, Clear channel is chosen, the detection range is 11200lux for fluorescent lamp, 1900lux for incandescent lamp; 100, ALS channel detection range is 516lux; 101, ALS channel detection range is 2064lux; 110, ALS channel detection range is 8256lux; 111, Clear channel is chosen, the detection range is 5600lux for fluorescent lamp, 950lux for incandescent lamp

Table 4. Register 0x03 (ALS\_DATA1) – Lower 8 bits of ALS/CLEAR Data

Bit	Access	Default	Name	Descriptions
7:0	R/W	0x00	ALS_DATA1	ALS_DATA[7..0] When Range[2:0]=3b’x11, it’s the lower byte of Clear channel; When Range[2:0]= others, it’s the lower byte of ALS channel

Table 5. Register 0x04 (ALS\_DATAH) – Upper 8 bits of ALS/CLEAR Data

Bit	Access	Default	Name	Descriptions
7:0	R/W	0x00	ALS_DATAH	ALS_DATA[15..8] When Range[2:0]=3b’x11, it’s the upper byte of Clear channel; When Range[2:0]= others, it’s the upper byte of ALS channel

Table 6. ALS Interrupt Threshold Registers (0x05)

Bit	Access	Default	Name	Descriptions
7:0	RW	0x00	INT_LTL	Lower byte of interrupt low threshold , INT_LT[7..0]

Table 7. ALS Interrupt Threshold Registers (0x06)

Bit	Access	Default	Name	Descriptions
7:0	RW	0x00	INT_LTH	Upper byte of interrupt low threshold, INT_LT[15..8]

Table 8. ALS Interrupt Threshold Registers (0x07)

Bit	Access	Default	Name	Descriptions
7:0	RW	0xFF	INT_HTL	Lower byte of interrupt high threshold, INT_HT[7..0]

Table 9. ALS Interrupt Threshold Registers (0x08)

Bit	Access	Default	Name	Descriptions
7:0	RW	0xFF	INT_HTH	Upper byte of interrupt high threshold, INT_HT[15..8]

## I<sup>2</sup>C Read / Write Register Data

The IC's I<sup>2</sup>C slave address is 0x44 when ADDR pin is tied to GND or 0x45 when ADDR pin is tied to VDD. Figures 2 and 3 detail the protocol of writing or reading the register data inside the SY3079AS22-J01.

- A : Acknowledge (0)
- NA : Not Acknowledged (1)
- P : Stop Condition
- R : Read (1)
- W : Write (0)
- S : Start Condition
- Sr : Repeat Start
- :: : Continuation of Protocol
- ▭ : Mater to Slave
- ▭ : Slave to Mater

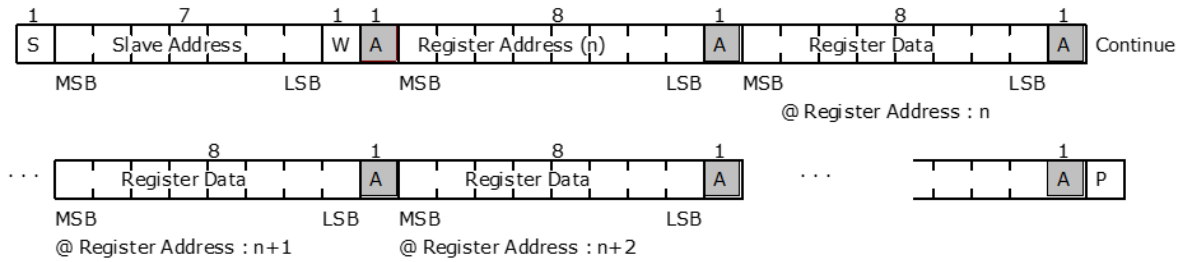

Figure 2. I<sup>2</sup>C Write-Register-Data Protocol

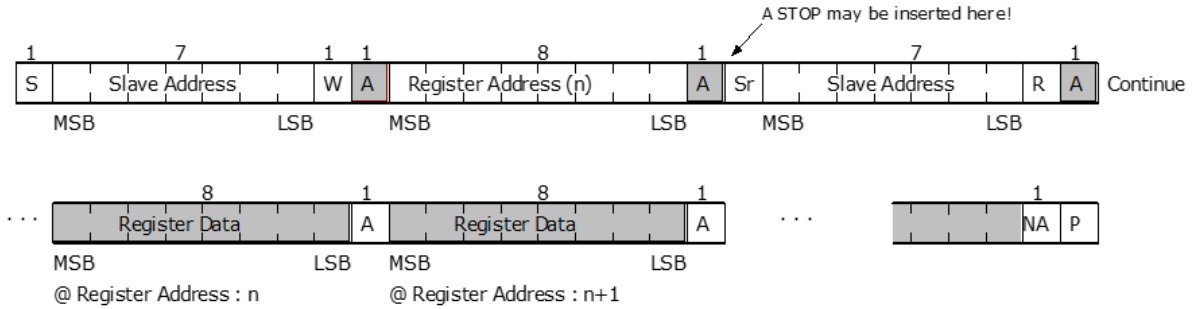

Figure 3. I<sup>2</sup>C Read-Register-Data Protocol

## Ambient Light Sensing

Shown in Figure 4 is the relative spectral response of SY3079AS22-J01. ALS channel spectral response matches human eye’s photopic vision curve perfectly. Under the same illuminance (lux), the ratio of ALS channel ADC reading of an incandescent lamp (rich of IR radiation) to that of a fluorescent lamp (no IR radiation) is close to 1.0.

Due to full spectral response of Clear channel and no IR radiation for fluorescent and white LED light source, the ratio of ADC reading of fluorescent to that of white LED is also close to 1.0. Then when exposed to incandescent light source (rich of IR radiation), Clear channel ADC reading shall increase rapidly. This Clear channel data changing will help to tell the external light source type.

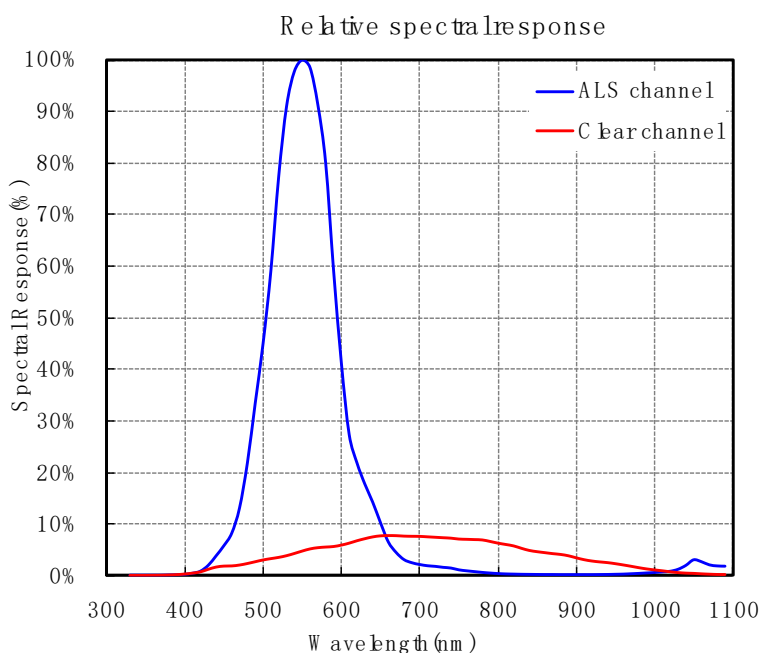

Figure 4. Spectral Responses of SY3079AS22-J01

Power grid worldwide is distributed at either 50Hz or 60Hz. Artificial light sources vary in intensity at the power grid frequencies. This varying light intensity is the root cause of AC noise for light sensors. To eliminate noises caused by power grid, the integration time of internal ADC shall be an integer multiple of periodic noise signal. For example, a 50Hz AC unwanted signal’s sum from 0ms to  $n \cdot 20\text{ms}$  ( $n=1,2,\dots,n_i$ ) is 0.

Integration time of SY3079AS22-J01 can be configured as either 200ms by setting bit 2 at register CON2 to 0, or 400ms by setting this bit to 1. Due to 200ms and 400ms are integer multiple of noise period induced by power grid with either 50Hz or 60Hz, the stability of sensor output data is greatly improved in the presence of noise.

## Interrupt Function

ALS interrupt is governed by the high and low thresholds in registers 0x05 to 0x08. The INT\_FLAG is set when the ALS reading (ALS\_DATA) exceeds the high ALS interrupt threshold (INT\_HTL & INT\_HTH) or falls below the low ALS interrupt threshold (INT\_LTL & INT\_LTH). The interrupt flag will be cleared when a write-operation is done on Register 0x01. The terminal INTn will be reset to high impedance (HZ) accordingly.

To further control when an interrupt occurs, SY3079AS22-J01 provides a persistence filter which allows the user to specify the number of consecutive out-of-range ALS readings before an interrupt is asserted. See Figure 5 for details where PRST is 1. Once the persistence filter generates an interrupt, INT\_FLAG will be set and the

terminal INTn will be set to low.

If only the above-high-threshold interrupt is required, set the low threshold value 0x0000. If only the below-low-threshold interrupt is required, set the high threshold value 0xFFFF. If no interrupt is required, set the high threshold value 0xFFFF, and the low threshold value 0x0000, which is the default setting.

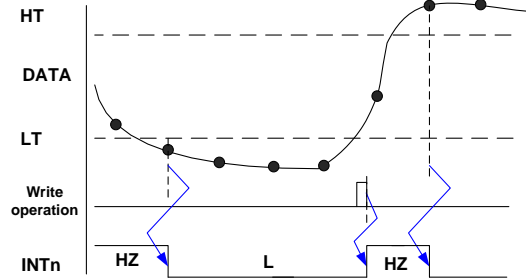
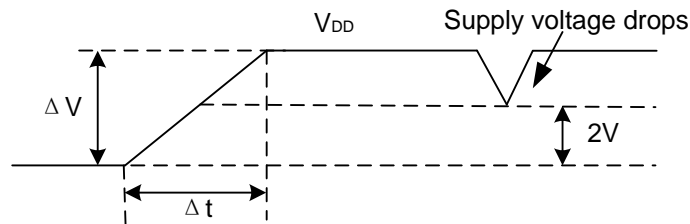

Figure. 5 ALS Interrupt Example

## VDD Power-up and Power Supply Considerations

Upon power-up, please ensure the slew rate of VDD greater than 0.5V/ms. After power-up, the supply voltage shall NOT drop below 2.0V. Once it happens, please switch off the power, wait more than 1 second to discharge power supply of IC(to get a reliable Power-On-Reset command), and then power on the device again.



$$\text{Slew rate} = \Delta V / \Delta t > 0.5V/ms$$

Figure 6. Waveform of Supply Voltage VDD

## Typical Application Circuit

A typical application for the SY3079AS22-J01 is shown in Figure 7. The device can be tied onto a system's I<sup>2</sup>C bus together with other I<sup>2</sup>C compliant devices.

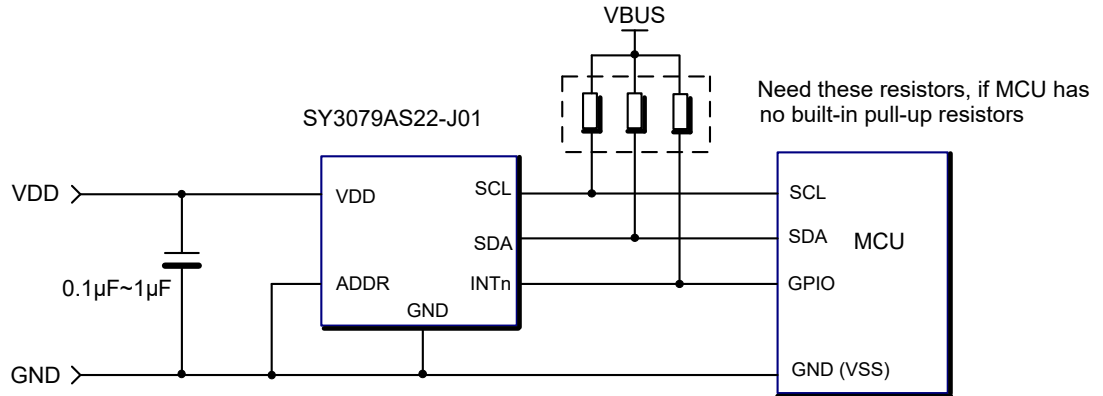

Figure 7. Typical Application Schematic Diagram

## Layout Considerations

The SY3079AS22-J01 is relatively insensitive to layout. Like other I<sup>2</sup>C devices, it is intended to provide excellent performance even in significantly noisy environments. There are only a few considerations that will ensure best performance. Route the supply and I<sup>2</sup>C traces as far as possible from all sources of noise. A 0.1µF to 1µF power supply decoupling capacitor needs to be placed close to the device.

## Typical Performance Curves

### Spectral Response

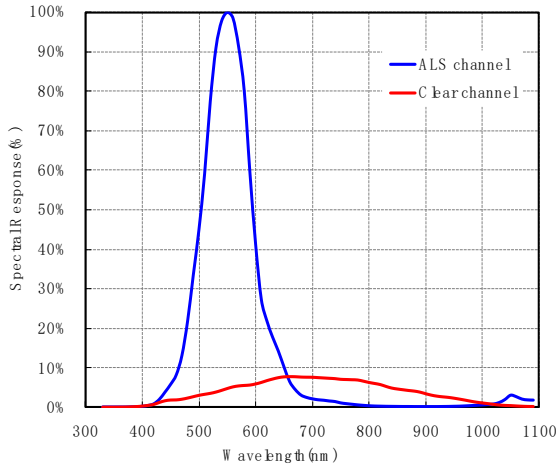

### ADC Reading vs Illuminance

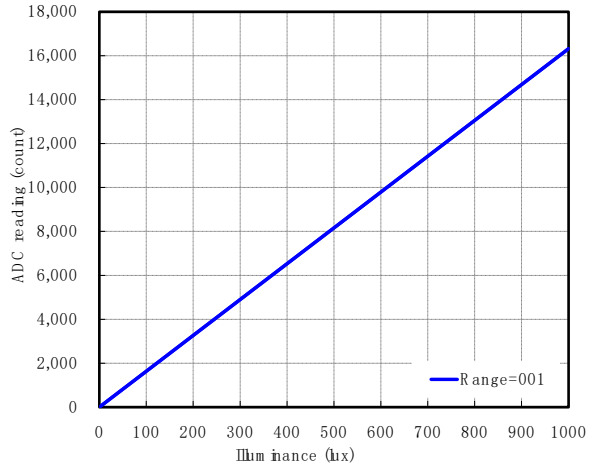

### Supply Current vs. Supply Voltage

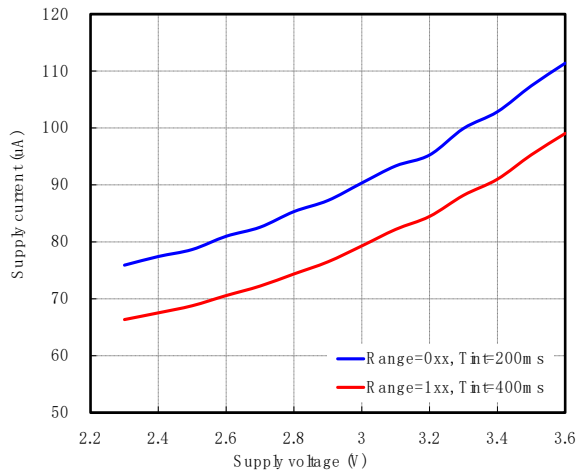

### ALS Data vs. Supply Voltage

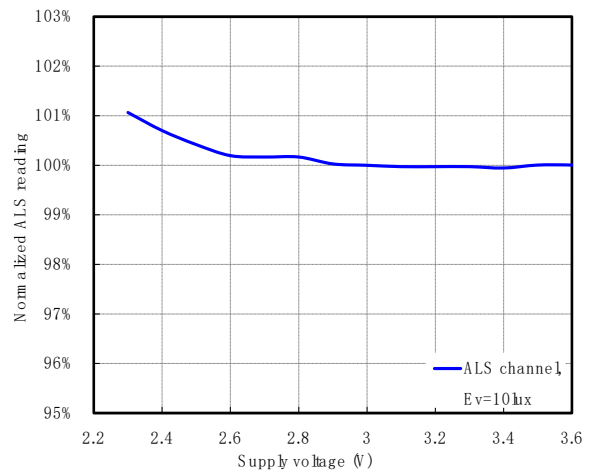

### Normalized Output vs. Angular Displacement

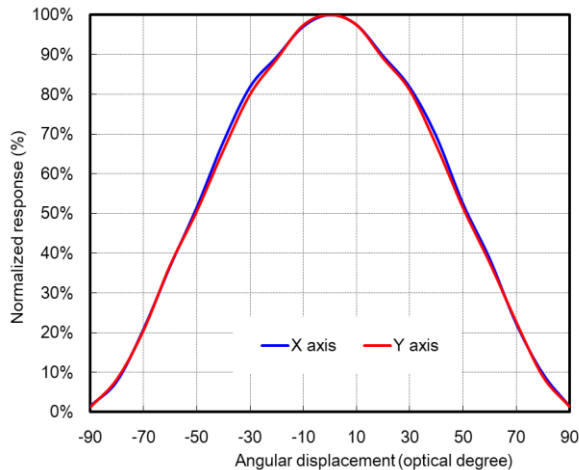

## Package Outline Dimensions

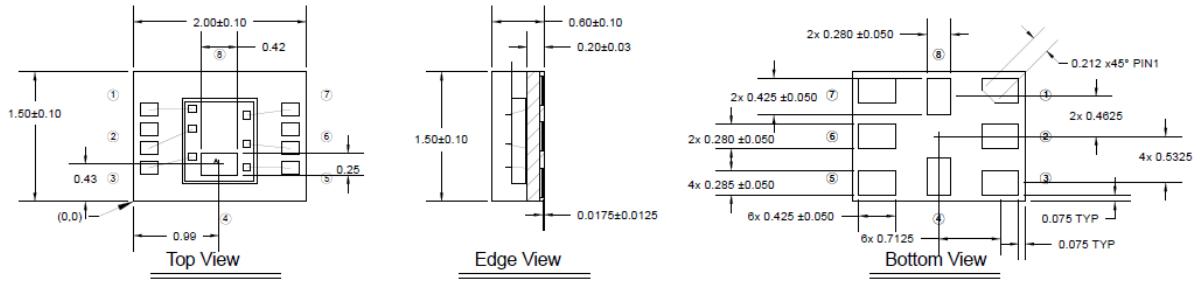

### PIN Information

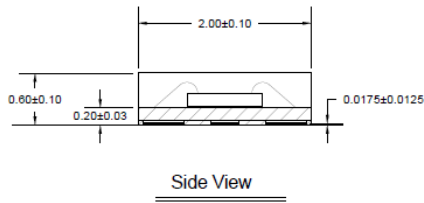

Name	PIN Assignmnet
PIN 1	ADDR
PIN 2	VDD
PIN 3	GND
PIN 4	NC1
PIN 5	SCL
PIN 6	SDA
PIN 7	INTn
PIN 8	NC2

### Notes:

- [1]. All tolerances are  $\pm 0.1$ mm, unless otherwise specified.
- [2]. ALS Sensor center is at point A,  $(X, Y) = (0.99, 0.43)$ .
- [3]. ALS PD area:  $420\mu\text{m} \times 250\mu\text{m}$ .
- [4]. BT substrate thickness is 0.2mm.



• Dimensions of Tape (Unit: mm)

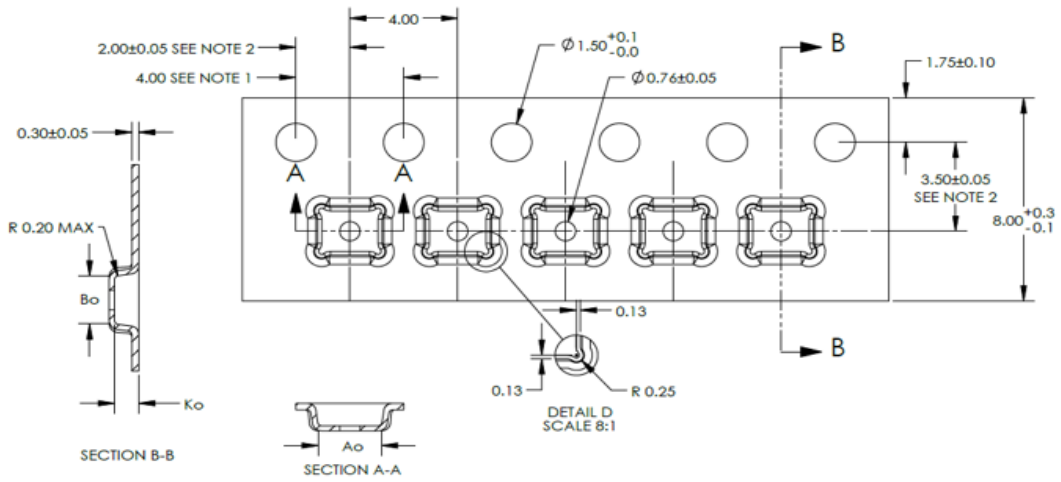

	DIM	±
Ao	2.35	0.05
Bo	1.85	0.05
Ko	0.88	+0.05/-0.10

## Recommended Method of Storage

Storage is recommended as soon as the bag has been opened to prevent moisture absorption. The following conditions should be observed, if bags are not available:

- Storage temperature: 10°C to 30°C
- Storage humidity:  $\leq 60\%$  RH max.
- Storage Time:  $\leq 168$ hr max.

## Moisture-Proof Package

To avoid moisture absorption by the resin, the product should be stored under the following conditions:

- Temperature:  $23 \pm 5^\circ\text{C}$
- Relative humidity: 60% (max)
- Baking is required if the devices have been store unopened for more than six months.

## ESD Precaution

Proper storage and handling procedures should be followed to prevent ESD damage to the devices especially when they are removed from the Anti-static bag. Electro-Static Sensitive Devices warning labels are on the packing.

## Make any necessary soldering correction manually

Temperature shall be no more than  $350^\circ\text{C}$  (25W for soldering iron) within 3 seconds. Make sure do not do this more than one time for any given pin.

## Recommended Solder Profile

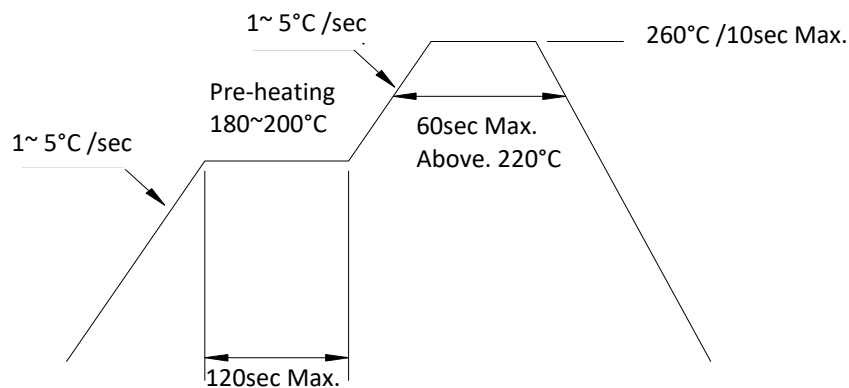

Note:

- [1]. Reflow soldering should not be done more than twice.
- [2]. Do not put stress on the devices during heating stage while soldering.
- [3]. Do not warp the circuit board after soldering.

## Revision History

The revision history provided is for informational purpose only and is believed to be accurate, however, not warranted. Please make sure that you have the latest revision.

<b>Date</b>	<b>Revision</b>	<b>Change</b>
Feb. 19, 2025	Revision 1.0A	Update Package Outline Drawings
Nov. 17, 2022	Revision 1.0	Production release
Nov. 17, 2021	Revision 0.9B	Update POD information
Apr. 12, 2021	Revision 0.9A	1. Update function block diagram (add ADDR pin) 2. Revise ADDR pin description (ADDR pulled high for slave address 0x45, pulled low for slave address 0x44)
Aug. 26, 2020	Revision 0.9	Initial Release

**IMPORTANT NOTICE**

1. **Right to make changes.** Silergy and its subsidiaries (hereafter Silergy) reserve the right to change any information published in this document, including but not limited to circuitry, specification and/or product design, manufacturing or descriptions, at any time and without notice. This document supersedes and replaces all information supplied prior to the publication hereof. Buyers should obtain the latest relevant information before placing orders and should verify that such information is current and complete. All semiconductor products are sold subject to Silergy's standard terms and conditions of sale.
2. **Applications.** Application examples that are described herein for any of these products are for illustrative purposes only. Silergy makes no representation or warranty that such applications will be suitable for the specified use without further testing or modification. Buyers are responsible for the design and operation of their applications and products using Silergy products. Silergy or its subsidiaries assume no liability for any application assistance or designs of customer products. It is customer's sole responsibility to determine whether the Silergy product is suitable and fit for the customer's applications and products planned. To minimize the risks associated with customer's products and applications, customer should provide adequate design and operating safeguards. Customer represents and agrees that it has all the necessary expertise to create and implement safeguards which anticipate dangerous consequences of failures, monitor failures and their consequences, lessen the likelihood of failures that might cause harm and take appropriate remedial actions. Silergy assumes no liability related to any default, damage, costs or problem in the customer's applications or products, or the application or use by customer's third-party buyers. Customer will fully indemnify Silergy, its subsidiaries, and their representatives against any damages arising out of the use of any Silergy components in safety-critical applications. It is also buyers' sole responsibility to warrant and guarantee that any intellectual property rights of a third party are not infringed upon when integrating Silergy products into any application. Silergy assumes no responsibility for any said applications or for any use of any circuitry other than circuitry entirely embodied in a Silergy product.
3. **Limited warranty and liability.** Information furnished by Silergy in this document is believed to be accurate and reliable. However, Silergy makes no representation or warranty, expressed or implied, as to the accuracy or completeness of such information and shall have no liability for the consequences of use of such information. In no event shall Silergy be liable for any indirect, incidental, punitive, special or consequential damages, including but not limited to lost profits, lost savings, business interruption, costs related to the removal or replacement of any products or rework charges, whether or not such damages are based on tort or negligence, warranty, breach of contract or any other legal theory. Notwithstanding any damages that customer might incur for any reason whatsoever, Silergy' aggregate and cumulative liability towards customer for the products described herein shall be limited in accordance with the Standard Terms and Conditions of Sale of Silergy.
4. **Suitability for use.** Customer acknowledges and agrees that it is solely responsible for compliance with all legal, regulatory and safety-related requirements concerning its products, and any use of Silergy components in its applications, notwithstanding any applications-related information or support that may be provided by Silergy. Silergy products are not designed, authorized or warranted to be suitable for use in life support, life-critical or safety-critical systems or equipment, nor in applications where failure or malfunction of an Silergy product can reasonably be expected to result in personal injury, death or severe property or environmental damage. Silergy assumes no liability for inclusion and/or use of Silergy products in such equipment or applications and therefore such inclusion and/or use is at the customer's own risk.
5. **Terms and conditions of commercial sale.** Silergy products are sold subject to the standard terms and conditions of commercial sale, as published at <http://www.silergy.com/stdterms>, unless otherwise agreed in a valid written individual agreement specifically agreed to in writing by an authorized officer of Silergy. In case an individual agreement is concluded only the terms and conditions of the respective agreement shall apply. Silergy hereby expressly objects to and denies the application of any customer's general terms and conditions with regard to the purchase of Silergy products by the customer.
6. **No offer to sell or license.** Nothing in this document may be interpreted or construed as an offer to sell products that is open for acceptance or the grant, conveyance or implication of any license under any copyrights, patents or other industrial or intellectual property rights. Silergy makes no representation or warranty that any license, either express or implied, is granted under any patent right, copyright, mask work right, or other intellectual property right. Information published by Silergy regarding third-party products or services does not constitute a license to use such products or services or a warranty or endorsement thereof. Use of such information may require a license from a third party under the patents or other intellectual property of the third party, or a license from Silergy under the patents or other intellectual property of Silergy.

For more information, please visit: [www.silergy.com](http://www.silergy.com)

© 2025 Silergy Corp.

**All Rights Reserved.**