

### General Description

The SY5881 is a single stage Buck PFC controller targeting at LED lighting applications with PWM or Analog dimming. It is a Buck converter operates in the quasi-resonant mode to achieve higher efficiency and keeps in constant on time operation to achieve high power factor. It adopts special design to achieve quick start up and reliable protection for safety requirement.

### Ordering Information

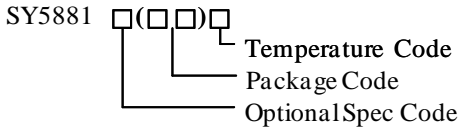

Ordering Number	Package type	Note
SY5881FAC	SO8	----

### Features

- High Dimming Accuracy
- Dimming Range from 5.5% to 100%
- CV Mode for Bias Supply at <2.5% Dimming Signal
- Valley Turn-on of the MOSFET to Achieve Low Switching Losses
- Quick Start Up <500ms
- Internal High Current MOSFET Driver: 200mA Sourcing and 650mA Sinking
- Low Start Up Current: 34μA Typical
- Reliable Short LED and Open LED Protection
- Power Factor >0.90
- RoHS Compliant and Halogen Free
- Compact Package: SO8

### Applications

- LED Lighting

### Typical Applications

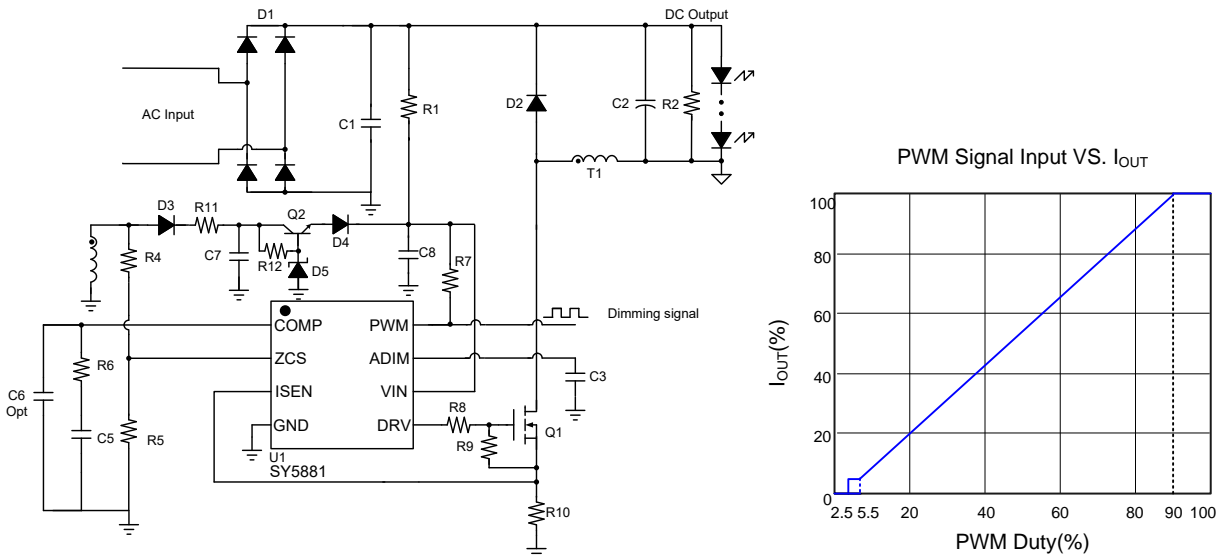

Figure.1a Analog dimming with PWM signal input

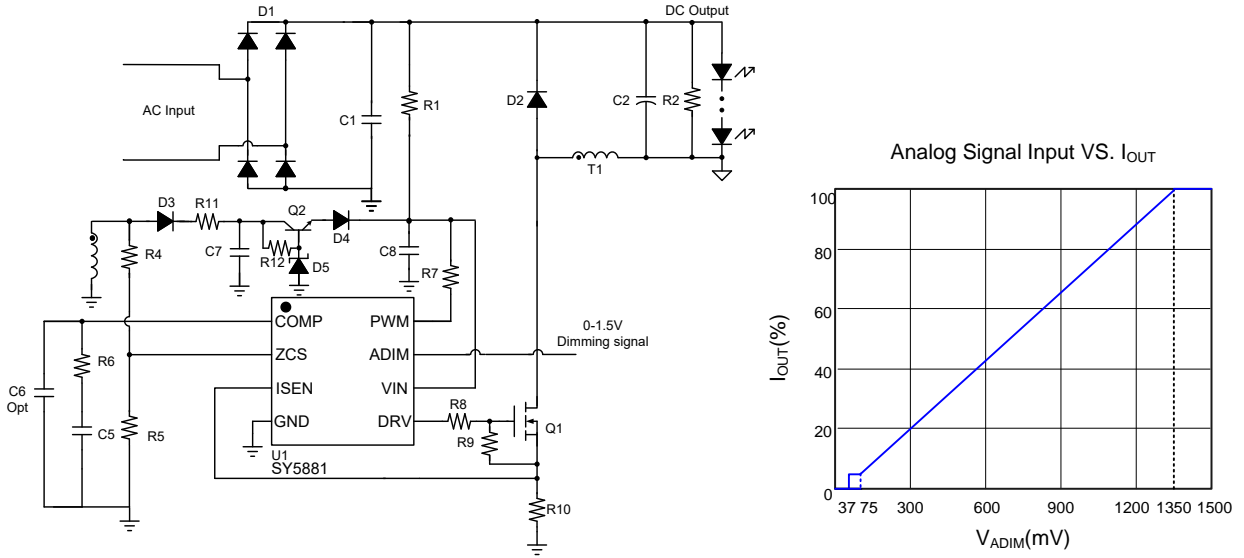

Figure.1b Dimming curve of analog dimming

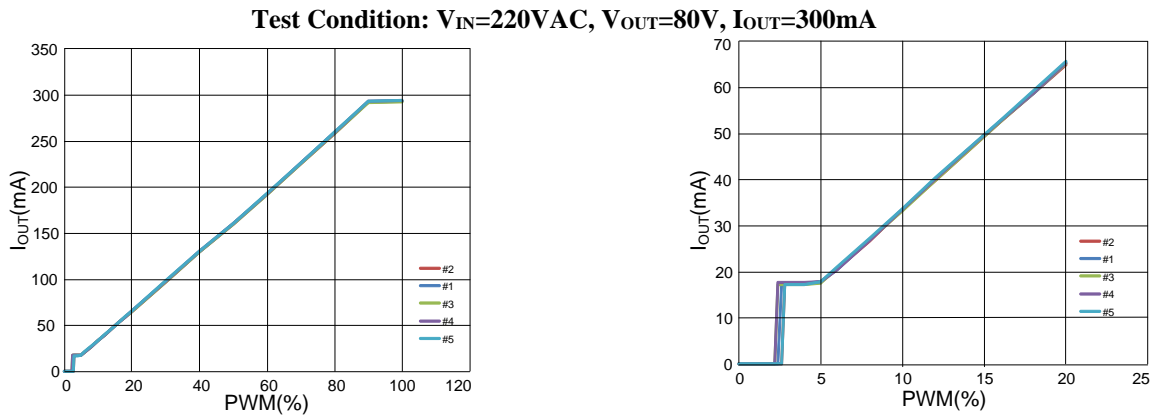
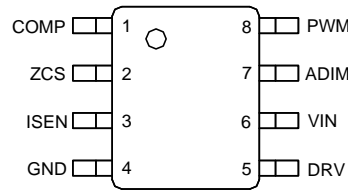

Figure.1c Actual curve of analog dimming VS. PWM input

## Pinout (top view)



(SO8)

**Top Mark: BEHxyz** (device code: BEH, x=year code, y=week code, z=lot number code)

Pin Name	Pin number	Pin Description
COMP	1	Loop compensation pin. Connect a RC network across this pin and ground to stabilize the control loop.
ZCS	2	Inductor current zero-crossing detection pin. This pin receives the auxiliary winding voltage by a resistor divider and detects the inductor current zero crossing point. This pin also provides over voltage protection and line regulation modification function simultaneously. If the voltage on this pin is above $V_{ZCS,OV}$ , the IC would enter over voltage protection mode. Good line regulation can be achieved by adjusting the upper resistor of the divider.
ISEN	3	Current sense pin. Connect this pin to the source of the switch. Connect the sense resistor across the source of the switch and the GND pin. (current sense resistor $R_S$ : $R_S = \frac{V_{REF}}{2 \times I_{OUT}}$ )
GND	4	Ground pin
DRV	5	Gate driver pin. Connect this pin to the gate of MOSFET.
VIN	6	Power supply pin. This pin also provides output over voltage protection along with ZCS pin.
ADIM	7	Bypass this pin to GND with enough capacitance to hold on internal voltage reference.
PWM	8	PWM dimming input pin, this pin detects the PWM dimming signal

## Block Diagram

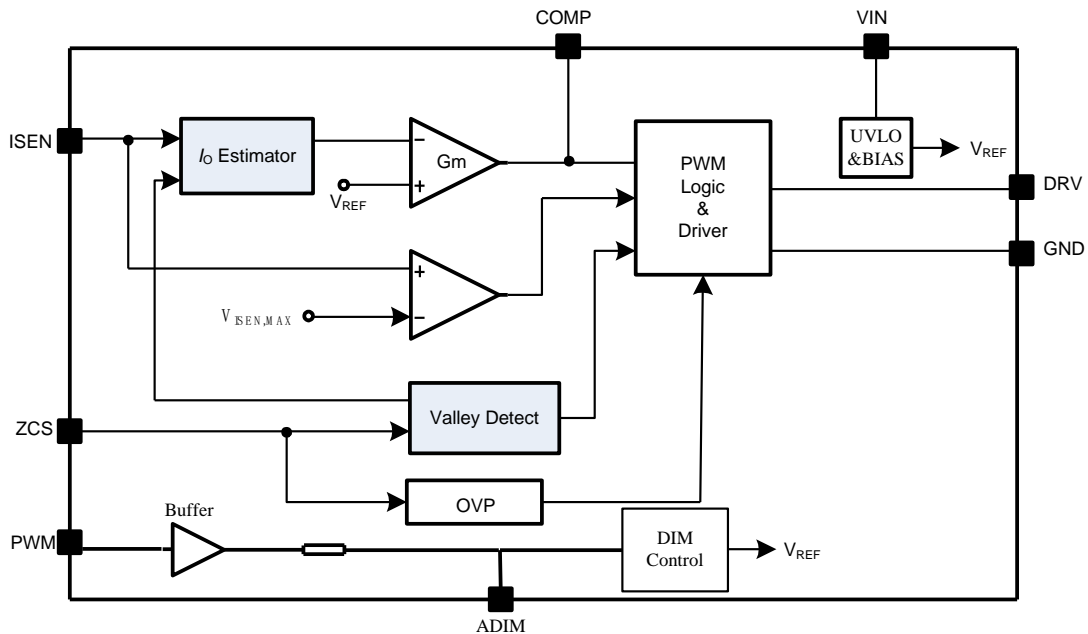

Figure.3 Block Diagram

### Absolute Maximum Ratings (Note 1)

VIN, DRV	-----	-0.3V~25V
Supply current I <sub>VIN</sub>	-----	7mA
ZCS, PWM	-----	-0.3V~23V
ADIM	-----	-0.3V~15V
ISEN, COMP	-----	-0.3~ 3.6V
Power Dissipation, @ T <sub>A</sub> = 25°C SO8	-----	1.1W
Package Thermal Resistance (Note 2)		
SO8, θ <sub>JA</sub>	-----	88°C/W
SO8, θ <sub>JC</sub>	-----	45°C/W
Temperature Range	-----	-40°C to 150°C
Lead Temperature (Soldering, 10 sec.)	-----	260°C
Storage Temperature Range	-----	-65°C to 150°C

### Recommended Operating Conditions (Note 3)

VIN, DRV	-----	8V~20V
----------	-------	--------

## Electrical Characteristics

( $V_{IN} = 12V$  (Note 3),  $T_A = 25^\circ C$  unless otherwise specified)

Parameter	Symbol	Test Conditions	Min	Typ	Max	Unit
<b>Power Supply Section</b>						
VIN Turn-on Threshold	$V_{VIN\_ON}$		19.0	20.0	22.0	V
VIN Turn-off Threshold	$V_{VIN\_OFF}$		6.7	7.3	8.0	V
VIN OVP Voltage	$V_{VIN\_OVP}$			$V_{VIN\_ON}+4.0$		V
Start up Current	$I_{ST}$	$V_{VIN}<V_{VIN\_ON}$		34.0		$\mu A$
Shunt Current in OVP Mode	$I_{VIN\_OVP}$	$V_{VIN}>V_{VIN\_OVP}$		7.0		mA
<b>Error Amplifier Section</b>						
Internal Reference Voltage	$V_{REF}$		294	300	306	mV
<b>Current Sense Section</b>						
Current Limit Reference Voltage	$V_{ISEN\_MAX}$			750		mV
<b>ZCS Pin Section</b>						
ZCS Pin OVP Voltage Threshold	$V_{ZCS\_OVP}$			1.5		V
<b>Gate Driver Section</b>						
Gate Driver Voltage	$V_{Gate}$			12		V
Maximum Source Current	$I_{SOURCE}$			200		mA
Minimum Sink Current	$I_{SINK}$			650		mA
Max ON Time	$T_{ON\_MAX}$	$V_{COMP}=2.7V$		25		$\mu s$
Min ON Time	$T_{ON\_MIN}$			350		ns
Max OFF Time	$T_{OFF\_MAX}$			120		$\mu s$
Min OFF Time	$T_{OFF\_MIN}$			0.6		$\mu s$
Maximum Switching Frequency	$f_{MAX}$			120		kHz
<b>ADIM Function Section</b>						
ADIM Enable ON	$V_{ADIM\_ON}$			75		mV
ADIM Enable OFF	$V_{ADIM\_OFF}$			38		mV
<b>Thermal Section</b>						
Thermal Fold Back Temperature	$T_{FB}$			150		$^\circ C$
Thermal Shut Down Temperature	$T_{SD}$			160		$^\circ C$
<b>PWM Function Section</b>						
PWM ON Voltage	$V_{PWM\_ON}$				1.2	V
PWM OFF Voltage	$V_{PWM\_OFF}$		0.5			V

**Note 1:** Stresses beyond the “Absolute Maximum Ratings” may cause permanent damage to the device. These are stress ratings only. Functional operation of the device at these or any other conditions beyond those indicated in the operational sections of the specification is not implied. Exposure to absolute maximum rating conditions for extended periods may affect device reliability.

**Note 2:**  $\Theta_{JA}$  is measured in the natural convection at  $T_A = 25^\circ C$  on a low effective single layer thermal conductivity test board of JEDEC 51-3 thermal measurement standard. Test condition: Device mounted on 2” x 2” FR-4 substrate PCB, 2oz copper, with minimum recommended pad on top layer and thermal vias to bottom layer ground plane.

**Note 3:** Increase VIN pin voltage gradually higher than  $V_{VIN\_ON}$  voltage then turn down to 12V.

## Operation

The SY5881 is a single stage Buck and PFC controller targeting at LED lighting applications with multiple dimming function.

High power factor is achieved by constant on operation mode, with which the control scheme and the circuit structure are both simple.

SY5881 is compatible with Analog dimming and PWM dimming for different application.

In order to reduce the switching losses and improve EMI performance, Quasi-Resonant switching mode is applied, which means to turn on the power MOSFET at voltage valley; the start up current of SY5881 is rather small (34  $\mu$  A typically) to reduce the standby power loss further; The maximum switching frequency will clamp to 120 kHz to reduce switching losses and improve EMI performance when the converter is operated at light load condition.

SY5881 provides reliable protections such as Short Circuit Protection (SCP), Open LED Protection (OLP), Over Temperature Protection (OTP), etc.

SY5881 is available with SO8 package.

## Applications Information

### Start up

After AC supply or DC BUS is powered on, the capacitor  $C_{VIN}$  across VIN and GND pin is charged up by BUS voltage through a start up resistor  $R_{ST}$ . Once  $V_{VIN}$  rises up to  $V_{VIN\_ON}$ , the internal blocks start to work.  $V_{VIN}$  will be pulled down by internal consumption of IC until the auxiliary winding of Buck transformer could supply enough energy to maintain  $V_{VIN}$  above  $V_{VIN\_OFF}$ .

The whole start up procedure is divided into two sections shown in Fig.4.  $t_{STC}$  is the  $C_{VIN}$  charged up section, and  $t_{STO}$  is the output voltage build-up section. The start-up time  $t_{ST}$  is composed of  $t_{STC}$  and  $t_{STO}$ , and usually  $t_{STO}$  is much smaller than  $t_{STC}$ .

$t_{STO}$  is fast start-up stage, which will help to create output voltage quickly. After  $t_{STO}$ , if  $V_{ADIM}$  is less than  $V_{ADIM\_ON}$ , the IC will enter into CV mode. When  $V_{ADIM}$  is larger

than  $V_{ADIM\_ON}$ , the IC will work in constant on time mode.

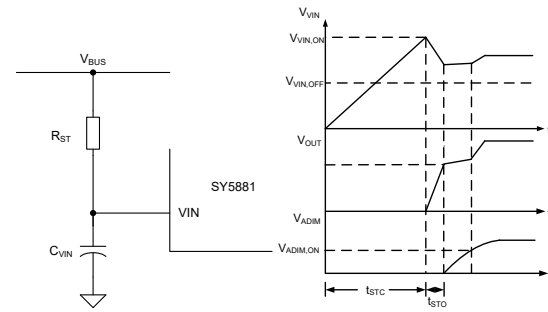

**Fig.4 Start up**

The start-up resistor  $R_{ST}$  and  $C_{VIN}$  are designed by rules below:

(a) Preset start-up resistor  $R_{ST}$ , make sure that the current through  $R_{ST}$  is larger than  $I_{ST}$  and smaller than 1mA.

$$\frac{V_{BUS}}{1mA} < R_{ST} < \frac{V_{BUS}}{I_{ST}} \quad (1)$$

Where  $V_{BUS}$  is the BUS line voltage.

(b) Select  $C_{VIN}$  to obtain an ideal start up time  $t_{ST}$ , and ensure the output voltage is built up at one time.

$$C_{VIN} = \frac{\left(\frac{V_{BUS}}{R_{ST}} - I_{ST}\right) \times t_{ST}}{V_{VIN\_ON}} \quad (2)$$

(c) If the  $C_{VIN}$  is not big enough to build up the output voltage at one time. Increase  $C_{VIN}$  and decrease  $R_{ST}$ , go back to step (a) and re-do such design flow until the ideal start up procedure is obtained.

### Internal pre-charge design for quick start up

After  $V_{VIN}$  exceeds  $V_{VIN\_ON}$ , SY5881 will work in peak current mode and the peak limit will follow with ZCS voltage.

Once ZCS is larger than 0.5V, If ADIM is lower than  $ADIM\_ON$ , SY5881 will enter CV mode. Otherwise, it will enter P3 working state.

In P3 working state,  $V_{COMP}$  is pre-charged by internal current source until it is over the initial voltage  $V_{COMP\_IC}$ .  $V_{COMP\_IC}$  can be programmed by  $R_{COMP}$ . Such design is meant to reduce the start up time shown in Fig.5.

The voltage pre-charged  $V_{COMP\_IC}$  in start-up procedure can be programmed by  $R_{COMP}$ :

$$V_{COMP\_IC} = 1.6V - 300\mu A \times R_{COMP} \quad (3)$$

Where  $V_{COMP\_IC}$  is the pre-charged voltage of COMP pin.

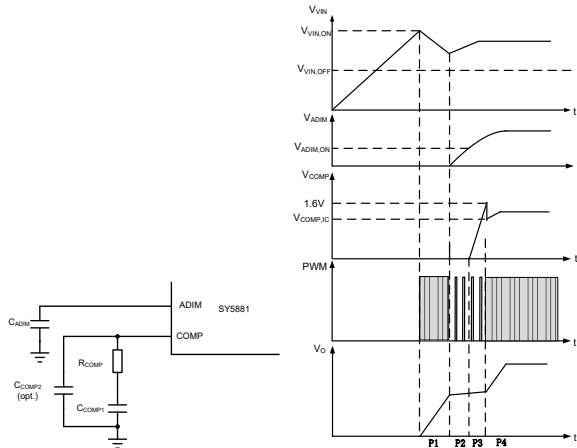

**Fig.5 Pre-charge scheme in start up**

Generally, a big capacitance of  $C_{COMP}$  is necessary to achieve high power factor and stabilize the system loop ( $1\mu F \sim 2\mu F$  recommended).

The voltage pre-charged in start-up procedure can be programmed by  $R_{COMP}$ ; On the other hand, larger  $R_{COMP}$  can provide larger phase margin for the control loop; A small ceramic capacitor is added to suppress high frequency interruption ( $10pF \sim 100pF$  is recommended if necessary)

### Shut down

After AC supply or DC BUS is powered off, the energy stored in the BUS capacitor will be discharged. When the auxiliary winding of Buck transformer can not supply enough energy to VIN pin,  $V_{VIN}$  will drop down. Once  $V_{VIN}$  is below  $V_{VIN\_OFF}$ , the IC will stop working and  $V_{COMP}$  will be discharged to zero.

### Constant-current control

The switching waveforms are shown in wave below. The output current  $I_{OUT}$  can be represented by,

$$I_{OUT} = \frac{I_{PK}}{2} \times \frac{t_{EFF}}{t_s} \quad (4)$$

Where  $I_{PK}$  is the peak current of the inductor;  $t_{EFF}$  is the effective time of inductor current rising and falling;  $t_s$  is the switching period.

$I_{PK}$  and  $t_{EFF}$  can be detected by Source and ZCS pin, which is shown in Fig.7. These signals are processed and applied to the negative input of the gain modulator. In static state, the positive and negative inputs are equal.

$$V_{REF} = I_{PK} \times R_S \times \frac{t_{EFF}}{t_s} \quad (5)$$

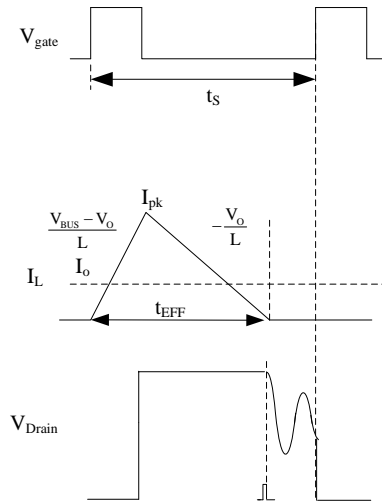

**Fig.6 Switching waveforms**

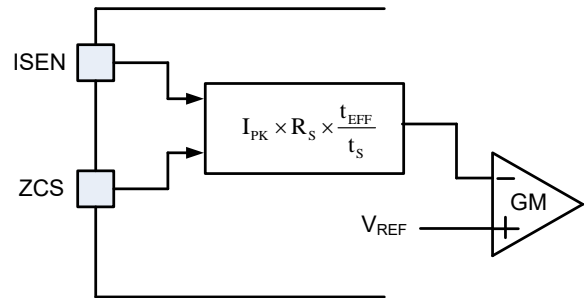

**Fig.7 Output current detection diagram**

Finally, the output current  $I_{OUT}$  can be represented by

$$I_{OUT} = \frac{V_{REF}}{R_S \times 2} \quad (6)$$

Where  $V_{REF}$  is the internal reference voltage;  $R_S$  is the current sense resistor.

$V_{REF}$  is internal constant parameters  $I_{OUT}$  can be programmed by  $R_S$ .

$$R_S = \frac{V_{REF}}{I_{OUT} \times 2} \quad (7)$$

### Quasi-Resonant Operation

QR mode operation provides low turn-on switching losses for the converter.

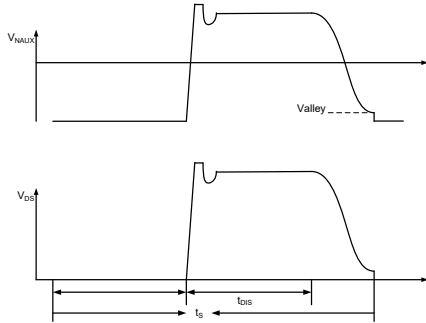

**Fig.8 QR mode operation**

The voltage across drain and source of the MOSFET is reflected by the auxiliary winding of the Buck transformer. ZCS pin detects the voltage across the auxiliary winding by a resistor divider. When the voltage across drain and source of the MOSFET is at voltage valley, the MOSFET would be turned on.

### CV Mode

When PWM < 2.5%, IC and MCU still need bias power, so,

- (1) If Dimming signal is greater than 5.0%, IC always works at CC mode.
- (2) If Dimming signal is lower than 2.5%, CV mode is triggered. IC works in CV mode to maintain V<sub>FB</sub> nearby V<sub>ZCS\_CV</sub> (0.5V). N<sub>p</sub>:N<sub>a</sub> and R<sub>ZCS</sub> could be adjusted to prevent LED flicker and bias supply enough.

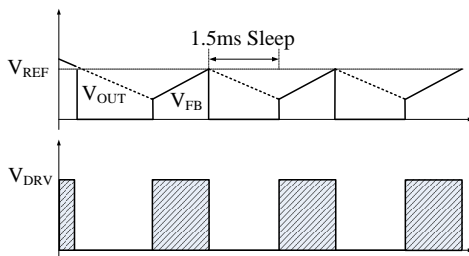

**Figure.9 The working process of CV mode**

In CV mode,

If V<sub>FB</sub> is smaller than V<sub>ZCS\_CV</sub> (0.5V), MOSFET turned off when I<sub>SEN</sub> voltage reach V<sub>CV\_ISEN\_MAX</sub> in every switching cycle, and turned on by QR.

If V<sub>FB</sub> is greater than V<sub>ZCS\_CV</sub> (0.5V), IC will sleep for 1.5ms, until V<sub>FB</sub> is smaller than V<sub>ZCS\_CV</sub> (0.5V).

The output of CV is decided by OVP.

$$V_{OUT\_CV} = \frac{V_{OUT\_OVP}}{3}$$

### Over Voltage Protection (OVP) & Open LED Protection (OLP)

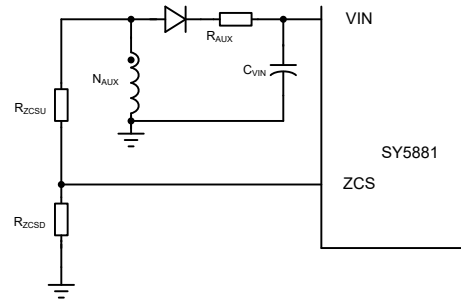

**Fig.10 OVP&OLP**

The output voltage is reflected by the auxiliary winding voltage of the Buck transformer, and both ZCS pin and VIN pin provide over voltage protection function. When the load is null or large transient happens, the output voltage will exceed the rated value. When V<sub>VIN</sub> exceeds V<sub>VIN\_OVP</sub> or V<sub>ZCS</sub> exceeds V<sub>ZCS\_OVP</sub>, the over voltage protection is triggered and the IC will discharge V<sub>VIN</sub> by an internal current source I<sub>VIN\_OVP</sub>. Once V<sub>VIN</sub> is below V<sub>VIN\_OFF</sub>, the IC will shut down and be charged again by BUS voltage through start up resistor. If the over voltage condition still exists, the system will operate in hiccup mode.

Thus, the turns of the auxiliary winding N<sub>AUX</sub> and the resistor divider is related with the OVP function.

$$\frac{V_{ZCS\_OVP}}{V_{OVP}} = \frac{N_{AUX}}{N_S} \times \frac{R_{ZCSD}}{R_{ZCSU} + R_{ZCSD}} \quad (8)$$

$$\frac{V_{VIN\_OVP}}{V_{OVP}} \geq \frac{N_{AUX}}{N_S} \quad (9)$$

Where V<sub>OVP</sub> is the output over voltage specification; R<sub>ZCSU</sub> and R<sub>ZCSD</sub> compose the resistor divider. The turns ratio of N<sub>S</sub> to N<sub>AUX</sub> and the ratio of R<sub>ZCSU</sub> to R<sub>ZCSD</sub> could be induced from equation (8) and (9).

## Short Circuit Protection (SCP)

When the output is shorted to ground, the output voltage is clamped to zero. The voltage of the auxiliary winding is proportional to the output winding, so  $V_{VIN}$  will drop down without auxiliary winding supply. Once  $V_{VIN}$  is below  $V_{VIN\_OFF}$ , the IC will shut down and be charged again by the BUS voltage through the start up resistor. If the short circuit condition still exists, the system will operate in hiccup mode.

In order to guarantee SCP function not effected by voltage spike of auxiliary winding, a filter resistor  $R_{AUX}$  is needed ( $5\Omega$  typically) shown in Fig.10.

## Line regulation modification

The IC provides line regulation modification function to improve line regulation performance.

Due to the sample delay of ISEN pin and other internal delay, the output current increases with increasing input BUS line voltage. A small compensation voltage  $\Delta V_{ISEN\_C}$  is added to ISEN pin during ON time to improve such performance. This  $\Delta V_{ISEN\_C}$  is adjusted by the upper resistor of the divider connected to ZCS pin.

$$\Delta V_{ISEN\_C} = V_{BUS} \times \frac{N_{AUX}}{N_P} \times \frac{1}{R_{ZCSU}} \times k_2 \quad (10)$$

Where  $R_{ZCSU}$  is the upper resistor of the divider;  $k_2$  is an internal constant as the modification coefficient.

The compensation is mainly related with  $R_{ZCSU}$ , larger compensation is achieved with smaller  $R_{ZCSU}$ . Normally,  $R_{ZCS}$  ranges from  $100k\Omega \sim 1M\Omega$ .

Then  $R_{ZCSD}$  can be selected by,

$$\frac{\frac{V_{ZCS\_OVP}}{V_{OUT}} \times \frac{N_S}{N_{AUX}}}{1 - \frac{V_{ZCS\_OVP}}{V_{OUT}} \times \frac{N_S}{N_{AUX}}} \times R_{ZCSU} > R_{ZCSD} \quad (11),$$

And,

$$R_{ZCSD} \geq \frac{\frac{V_{ZCS\_OVP}}{V_{OVP}} \times \frac{N_S}{N_{AUX}}}{1 - \frac{V_{ZCS\_OVP}}{V_{OVP}} \times \frac{N_S}{N_{AUX}}} \times R_{ZCSU} \quad (12)$$

Where  $V_{OVP}$  is the output over voltage protection specification;  $V_{OUT}$  is the rated output voltage;  $R_{ZCSU}$  is the upper resistor of the divider;  $N_S$  and  $N_{AUX}$  are the turns of secondary winding and auxiliary winding separately.

## Dimming Mode

SY5881 supports two dimming modes: PWM dimming and analog dimming. The dimming signal is given as PWM square waveform and the output current is up to the duty cycle of the dimming signal.

### Analog Dimming Mode

In Analog dimming mode, SY5881 is compatible with two dimming signal: PWM signal and 0-1.5V dimming signal, the output current is regulated by the voltage on ADIM pin.

If the dimming signal is PWM signal, it is given to PWM pin. When the voltage of PWM pin is higher than  $V_{PWM\_ON}$ , the dimming signal is sensed as high logic level, and ADIM pin is pulled up to 1.5V by a  $10k\Omega$  resistor; when the voltage is lower than  $V_{PWM\_OFF}$ , the dimming signal is sensed as low logic level, and ADIM pin is pulled down to GND by a  $10k\Omega$  resistor. The duty cycle of the dimming signal  $D_{DIM}$  is reflected by the voltage on ADIM pin  $V_{ADIM}$ .

$$V_{ADIM} = D_{DIM} \times 1.5V \quad (13)$$

When  $V_{ADIM}$  is lower than 37mV ( $D_{DIM}$  is 2.5%), the output current is zero; When  $V_{ADIM}$  is from  $V_{ADIM\_ON}$  to 75mV ( $D_{DIM}$  is from 2.5% to 5.0%), the output current is 5.5% of rated output current; When  $V_{ADIM}$  is higher than 1.35V ( $D_{DIM}$  is over 90.0%), the output current is 100% of rated output current; When  $V_{ADIM}$  is in the range from 75mV to 1.35V ( $D_{DIM}$  is from 5.0% to 90.0%),  $I_{OUT}$  increases with  $D_{DIM}$  linearly from 5.5% to 100% of rated output current.

The dimming curve between output current  $I_{OUT}$ ,  $V_{ADIM}$  and duty cycle of dimming signal is shown as below.

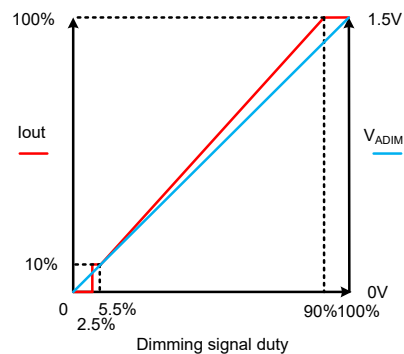

Fig.11 Dimming cure of analog dimming

A capacitor  $C_{ADIM}$  need be connected across ADIM and GND pin to obtain a smooth voltage waveform of the dimming signal duty cycle.  $C_{ADIM}$  is selected by

$$C_{ADIM} \geq \frac{10^{-3}}{f_{DIM}} \text{ F} \cdot \text{Hz} \quad (14)$$

Where  $f_{DIM}$  is the frequency of PWM dimming signal.

If the dimming signal is analog voltage, the dimming signal is given to ADIM pin directly. PWM pin should be pulled down to GND.

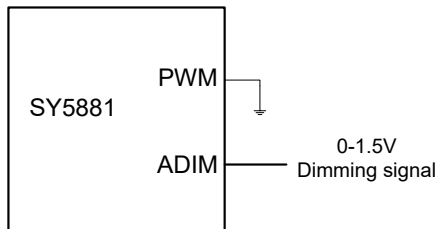

**Fig.12 Connection of Analog dimming with 0-1.5V dimming signal**

## Power Device Design

### MOSFET and Diode

When the operation condition is with maximum input voltage and full load, the voltage stress of MOSFET and output power diode is maximized;

$$V_{MOS\_DS\_MAX} = \sqrt{2}V_{AC\_MAX} \quad (17)$$

$$V_{D\_R\_MAX} = \sqrt{2}V_{AC\_MAX} \quad (18)$$

Where  $V_{AC\_MAX}$  is maximum input AC RMS voltage.

When the operation condition is with minimum input voltage and full load, the current stress of MOSFET and power diode is maximized.

### Inductor (L)

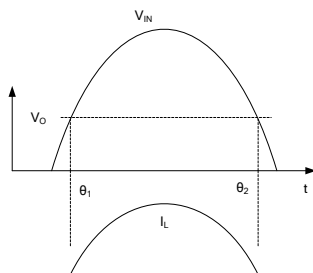

**Fig.13 Input waveforms**

The power is transferred from AC input to output only when the input voltage is larger than output voltage in Buck converter. The input voltage and inductor current waveforms are shown in Fig.13, where  $\theta_1$  and  $\theta_2$  are the time that input voltage is equal to output voltage.

In Quasi-Resonant mode, each switching period cycle  $t_s$  consists of three parts: current rising time  $t_1$ , current falling time  $t_2$  and quasi-resonant time  $t_3$  shown in Fig.15.

The system operates in the constant on time mode to achieve high power factor. The ON time increases with the input AC RMS voltage decreasing and the load increasing. When the operation condition is with minimum input AC RMS voltage and full load, the ON time is maximized. On the other hand, when the input voltage is at the peak value, the OFF time is maximized. Thus, the minimum switching frequency  $f_{S\_MIN}$  happens at the peak value of input voltage with minimum input AC

RMS voltage and maximum load condition; Meanwhile, the maximum peak current through MOSFET and the transformer happens.

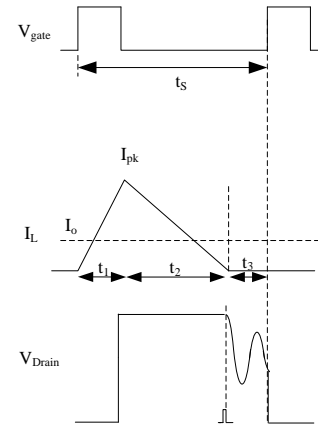

**Fig.14 switching waveforms**

Once the minimum frequency  $f_{S\_MIN}$  is set, the inductance of the transformer could be calculated. The design flow is shown as below:

(a) Preset minimum frequency  $f_{S\_MIN}$

(b) Compute relative  $t_s, t_1$

$$t_s = \frac{1}{f_{S\_MIN}} \quad (19)$$

$$t_1 = \frac{t_s \times (V_{OUT} + V_{DF})}{(\sqrt{2}V_{AC\_MIN} + V_{DF})} \quad (20)$$

$$t_2 = t_s - t_1 \quad (21)$$

Where  $V_{DF}$  is the forward voltage of the diode

(c) Design inductance L

$$\theta_1 = \arcsin\left(\frac{V_{OUT}}{\sqrt{2}V_{AC\_MIN}}\right) \times \frac{1}{\pi} \times \frac{1}{2 \times f_{AC}} \quad (22)$$

$$\theta_2 = \frac{1}{2 \times f_{AC}} - \theta_1 \quad (23)$$

$$L = \frac{\eta \times f_{AC} \times V_{OUT} \times t_1}{P_{OUT}} \times \left[ \sqrt{2}V_{AC\_MIN} \times \frac{\cos(2\pi f_{AC} \times \theta_1) - \cos(2\pi f_{AC} \times \theta_2)}{2\pi f_{AC}} - V_{OUT}(\theta_2 - \theta_1) \right] \quad (24)$$

Where  $\eta$  is the efficiency;  $P_{OUT}$  is rated full load power;

(d) Compute inductor maximum peak current  $I_{L\_PK\_MAX}$ .

$$I_{L\_PK\_MAX} = \frac{(\sqrt{2}V_{AC\_MIN} - V_{OUT}) \times t_1}{L} \quad (25)$$

Where  $I_{L\_PK\_MAX}$  is the maximum inductor peak current;

(f) Compute the RMS current of Buck inductor

$I_{L\_RMS\_MAX}$  is inductor RMS current of whole AC period

$$I_{L\_RMS\_MAX} = \frac{t_1}{\sqrt{3} \times L} \sqrt{V_{AC\_MIN}^2 + V_{OUT}^2 - \frac{4\sqrt{2}V_{AC\_MIN} \times V_{OUT}}{\pi}} \quad (26)$$

(g) Compute RMS current of the MOSFET

$$I_{L\_RMS\_MAX} = \sqrt{\frac{t_1}{3t_s} \times \frac{t_1}{L} \sqrt{V_{AC\_MIN}^2 + V_{OUT}^2 - \frac{4\sqrt{2}V_{AC\_MIN} \times V_{OUT}}{\pi}}} \quad (27)$$

## Inductor design (N, N<sub>AUX</sub>)

These parameters below are necessary:

Necessary parameters	
Inductance	L
inductor maximum current	$I_{L\_PK\_MAX}$
inductor maximum RMS current	$I_{L\_RMS\_MAX}$

The design rules are as followed:

(a) Select the magnetic core style, identify the effective area  $A_e$ .

(b) Preset the maximum magnetic flux  $\Delta B$

$$\Delta B = 0.22 \sim 0.26T$$

(c) Compute the turns N

$$N = \frac{L_M \times I_{L\_PK\_MAX}}{\Delta B \times A_e} \quad (28)$$

(d) Compute the auxiliary turns  $N_{AUX}$

$$N_{AUX} = N \times \frac{V_{VIN}}{V_{OUT}} \quad (29)$$

Where  $V_{VIN}$  is the working voltage of VIN pin (10V~11V is recommended).

(e) Select an appropriate wire diameter

With  $I_{L\_RMS\_MAX}$ , select appropriate wire to make sure the current density ranges from 4A/mm<sup>2</sup> to 10A/mm<sup>2</sup>.

(f) If the winding area of the core and bobbin is not enough, reselect the core style, go to (a) and redesign the transformer until the ideal transformer is achieved.

## Output capacitor C<sub>OUT</sub>

Preset the output current ripple  $\Delta I_{OUT}$ ,  $C_{OUT}$  is induced by

$$C_{OUT} = \frac{\sqrt{\left(\frac{2I_{OUT}}{\Delta I_{OUT}}\right)^2 - 1}}{4\pi f_{AC} R_{LED}} \quad (30)$$

Where  $I_{OUT}$  is the rated output current;  $\Delta I_{OUT}$  is the demanded current ripple;  $f_{AC}$  is the input AC supply frequency;  $R_{LED}$  is the equivalent series resistor of the LED load.

## Layout

(a) To achieve better EMI performance and reduce line frequency ripples, the output of the bridge rectifier should be connected to the BUS line capacitor first, then to the switching circuit.

(b) The circuit loop of all switching circuit should be kept small.

(c) The connection of ground is recommended as:

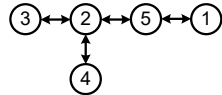

Ground ①: ground of BUS line capacitor

Ground ②: ground of bias supply capacitor and GND pin

Ground ③: ground node of auxiliary winding

Ground ④: ground of signal trace except GND pin

Ground ⑤: ground node of current sample resistor.

(d) Bias supply trace should be connected to the bias supply capacitor first instead of GND pin. The bias supply capacitor should be put beside the IC.

(e) Loop of ‘Source pin – current sample resistor – GND pin’ should be kept as small as possible.

(f) The resistor divider connected to ZCS pin is recommended to be put beside the IC.

(g) The control circuit is recommended to be put outside the power circuit loop.

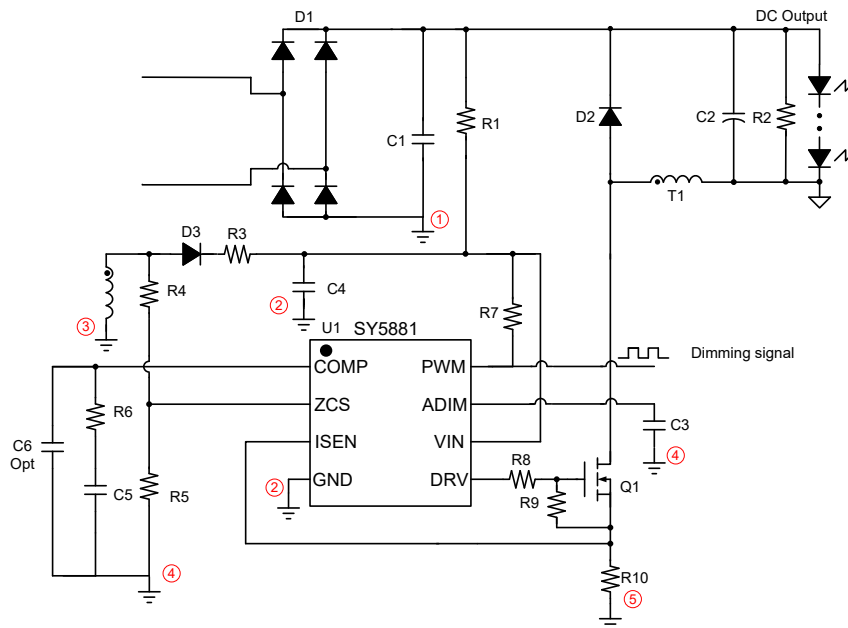

**Fig.16 Ground connection recommended**

## Design Example

A design example of typical application is shown below step by step.

### #1. Identify design specification

Design Specification			
V <sub>AC</sub> (RMS)	176V~264V	V <sub>OUT</sub>	24V
I <sub>OUT</sub>	300mA	η	92%

### #2. Inductor design (L)

Refer to Power Device Design

Conditions			
V <sub>AC_MIN</sub>	176V	V <sub>AC_MAX</sub>	264V
P <sub>OUT</sub>	7.2W	f <sub>S_MIN</sub>	46kHz

(a) f<sub>S\_MIN</sub> is preset

$$f_{S\_MIN} = 46\text{kHz}$$

(b) Compute the switching period t<sub>s</sub> and ON time t<sub>1</sub> at the peak of input voltage.

$$t_s = \frac{1}{f_{S\_MIN}} = 21.74\mu\text{s}$$

$$t_1 = \frac{t_s \times (V_{OUT} + V_{DF})}{(\sqrt{2}V_{AC\_MIN} + V_{DF})} = \frac{21.74\mu\text{s} \times (24\text{V} + 1\text{V})}{(\sqrt{2} \times 176\text{V} + 1\text{V})} = 2.17\mu\text{s}$$

$$t_2 = t_s - t_1 = 21.74\mu\text{s} - 2.17\mu\text{s} = 19.57\mu\text{s}$$

(c) Compute the inductance L

$$\theta_1 = \arcsin\left(\frac{V_{OUT}}{\sqrt{2}V_{AC\_MIN}}\right) \times \frac{1}{\pi} \times \frac{1}{2 \times f_{AC}} = \arcsin\left(\frac{24\text{V}}{\sqrt{2} \times 176\text{V}}\right) \times \frac{1}{\pi} \times \frac{1}{2 \times 50\text{Hz}} = 3.074 \times 10^{-4}\text{s}$$

$$\theta_2 = \frac{1}{2 \times f_{AC}} - \theta_1 = \frac{1}{2 \times 50\text{Hz}} - 3.074 \times 10^{-4}\text{s} = 9.693 \times 10^{-3}\text{s}$$

$$L = \frac{\eta \times f_{AC} \times V_{OUT} \times t_1}{P_{OUT}} \times$$

$$\left[ \sqrt{2}V_{AC\_MIN} \times \frac{\cos(2 \times \pi \times f_{AC} \times \theta_1) - \cos(2 \times \pi \times f_{AC} \times \theta_2)}{2 \times \pi \times f_{AC}} - V_{OUT}(\theta_2 - \theta_1) \right]$$

$$= \frac{0.92 \times 50\text{Hz} \times 24\text{V} \times 2.17\mu\text{s}}{7.2\text{W}} \times$$

$$\left[ \sqrt{2} \times 176\text{V} \times \frac{\cos(2\pi \times 50\text{Hz} \times 3.074 \times 10^{-4}\text{s}) - \cos(2\pi \times 50\text{Hz} \times 9.693 \times 10^{-3}\text{s})}{2\pi \times 50\text{Hz}} - 24\text{V}(9.693 \times 10^{-3}\text{s} - 3.074 \times 10^{-4}\text{s}) \right]$$

$$= 451\mu\text{H}$$

(d) Compute inductor maximum peak current I<sub>L-PK-MAX</sub>.

$$I_{L\_PK\_MAX} = \frac{(\sqrt{2}V_{AC\_MIN} - V_{OUT}) \times t_1}{L} = \frac{(\sqrt{2} \times 176 - 24) \times 2.17\mu\text{s}}{451\mu\text{H}} = 1.082\text{A}$$

Where  $I_{L\_PK\_MAX}$  is the maximum inductor peak current ;

(f) Compute RMS of the inductor current  $I_{L\_RMS\_MAX}$

$$I_{L\_RMS\_MAX} = \frac{t_1}{\sqrt{3} \times L} \sqrt{V_{AC\_MIN}^2 + V_{OUT}^2 - \frac{4\sqrt{2}V_{AC\_MIN} \times V_{OUT}}{\pi}}$$

$$= \frac{2.17\mu s}{\sqrt{3} \times 451\mu H} \sqrt{176V^2 + 24V^2 - \frac{4\sqrt{2} \times 176V \times 24V}{\pi}}$$

$$= 0.43A$$

#3. Select power MOSFET and power diode

Refer to Power Device Design

Known conditions at this step			
$V_{AC\_MAX}$	264V	$\eta$	92%
$V_{OUT}$	24V		

Compute the voltage and the current stress of MOSFET:

$$I_{L\_RMS\_MAX} = \sqrt{\frac{t_1}{3t_s} \times \frac{t_1}{L} \sqrt{V_{AC\_MIN}^2 + V_{OUT}^2 - \frac{4\sqrt{2}V_{AC\_MIN} \times V_{OUT}}{\pi}}}$$

$$= \sqrt{\frac{2.17\mu s}{3 \times 21.74\mu s} \times \frac{2.17\mu s}{451\mu H} \times \sqrt{176V^2 + 24V^2 - \frac{4\sqrt{2} \times 176V \times 24V}{\pi}}}$$

$$= 0.136A$$

#4. Select the output capacitor  $C_{OUT}$

Refer to Power Device Design

Conditions			
$I_{OUT}$	300mA	$\Delta I_{OUT}$	$0.3I_{OUT}$
$f_{AC}$	50Hz	$R_{LED}$	$7 \times 1.6\Omega$

The output capacitor is

$$C_{OUT} = \frac{\sqrt{\left(\frac{2I_{OUT}}{\Delta I_{OUT}}\right)^2 - 1}}{4\pi f_{AC} R_{LED}}$$

$$= \frac{\sqrt{\left(\frac{2 \times 0.3A}{0.5 \times 0.3A}\right)^2 - 1}}{4\pi \times 50Hz \times 7 \times 1.6\Omega}$$

$$= 550\mu F$$

#5. Set VIN pin

Refer to Start up

Conditions			
V <sub>BUS_MIN</sub>	176V × 1.414	V <sub>BUS_MAX</sub>	264V × 1.414
I <sub>ST</sub>	34μA (typical)	V <sub>IN_ON</sub>	20V (typical)
I <sub>VIN_OVP</sub>	7mA (typical)	t <sub>ST</sub>	500ms (designed by user)

(a) R<sub>ST</sub> is preset

$$R_{ST} < \frac{V_{BUS}}{I_{ST}} = \frac{176V \times 1.414}{15\mu A} = 16.59M\Omega,$$

$$R_{ST} > \frac{V_{BUS}}{I_{VIN\_OVP}} = \frac{264V \times 1.414}{2mA} = 186.7k\Omega$$

Set R<sub>ST</sub>

$$R_{ST} = 300k\Omega \times 2 = 600k\Omega$$

(b) Design C<sub>VIN</sub>

$$C_{VIN} = \frac{\left(\frac{V_{BUS}}{R_{ST}} - I_{ST}\right) \times t_{ST}}{V_{VIN\_ON}}$$

$$= \frac{\left(\frac{176V \times 1.414}{600k\Omega} - 34\mu A\right) \times 500ms}{22V}$$

$$= 8.6\mu F$$

Set C<sub>VIN</sub>

$$C_{VIN} = 10\mu F$$

#6 Set COMP pin

Refer to **Internal pre-charge design for quick start up**

Parameters designed			
R <sub>COMP</sub>	1.5kΩ	V <sub>COMP_IC</sub>	900mV
C <sub>COMP1</sub>	2μF	C <sub>COMP2</sub>	0

#7 Set current sense resistor to achieve ideal output current

Refer to **constant-current control**

Known conditions at this step			
V <sub>REF</sub>	0.3V	I <sub>OUT</sub>	0.3A

The current sense resistor is

$$R_s = \frac{V_{REF}}{2 \times I_{OUT}} = \frac{0.3}{2 \times 0.3A} = 0.5\Omega$$

#8 set ZCS pin

Refer to **Line regulation modification** and **Over Voltage Protection (OVP) & Open Loop Protection (OLP)**

First identify  $R_{ZCSU}$ . need for line regulation.

Known conditions at this step			
Parameters Designed			
$R_{ZCSU}$	200k $\Omega$	$k_1$	68

Then compute  $R_{ZCSD}$

Conditions			
$V_{ZCS\_OVP}$	1.42V	$V_{OVP}$	32V
$V_{OUT}$	24V		
Parameters designed			
$R_{ZCSU}$	200k $\Omega$		
N	100	$N_{AUX}$	45

$$V_{IN\_CV} = \frac{0.5 \times (R_{ZCSU} + R_{ZCSD})}{R_{ZCSD}} = 11$$

$$R_{ZCSD} = \frac{0.5 \times R_{ZCSU}}{V_{IN\_CV} - 0.5} = \frac{0.5 \times 200}{11 - 0.5} = 9.5k\Omega$$

$$N_{SA} = \frac{V_{OVP}}{V_{IN\_OVP}} = \frac{32}{24} = 1.33$$

$$V_{O\_CV} = V_{IN\_CV} \times N_{SA} = 11 \times 1.33V = 14.6V < \frac{2}{3} \times V_o = \frac{2}{3} \times 24 = 16V$$

$R_{ZCSD}$  is set to

$$R_{ZCSD} = 9.5k\Omega$$

#9 set ADIM and PWM pin

Refer to **Analog Dimming Mode Design**

Conditions			
$V_{PWM\_ON}$	0.8V		
Parameters Designed			
$R_{PWM\_UP}$	200k $\Omega$		

$$C_{ADIM} = \frac{10^{-3}}{f_{PWM}} F \times Hz = \frac{10^{-3}}{1000} F = 1\mu F$$

Hence  $C_{ADIM}$  is set to

$$C_{ADIM} = 1\mu F$$



**SO8 Package Outline & PCB Layout Design**

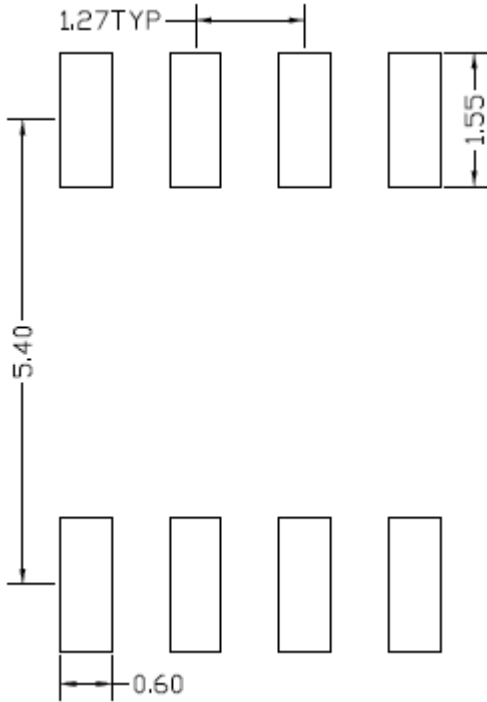

**Recommended Pad Layout  
(Reference only)**

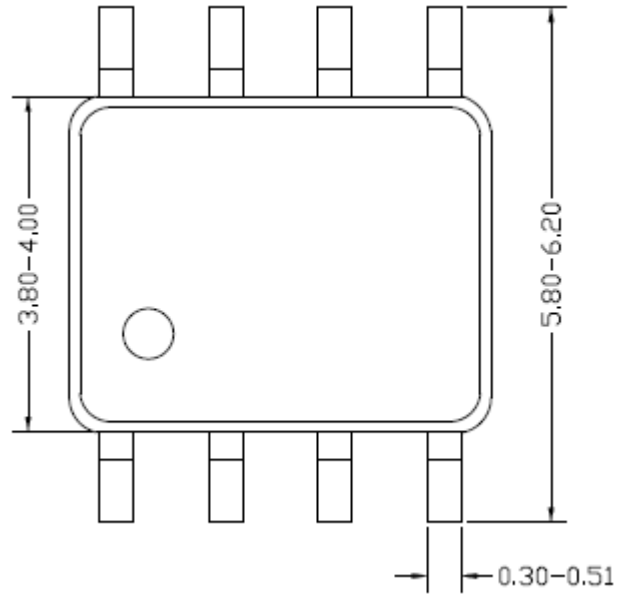

**Top view**

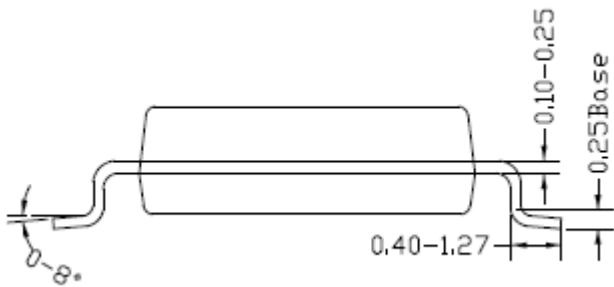

**Side view**

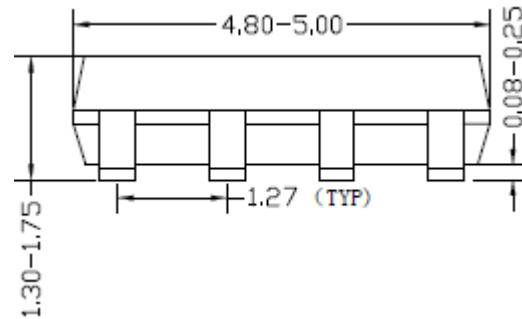

**Front view**

**Notes: All dimension in millimeter and exclude mold flash & metal burr.**

## Taping & Reel Specification

### 1. Taping orientation for packages (SO8)

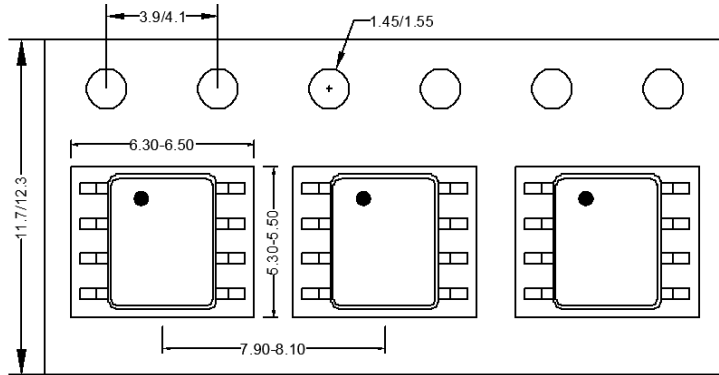

Feeding direction →

### 2. Carrier Tape & Reel specification for packages

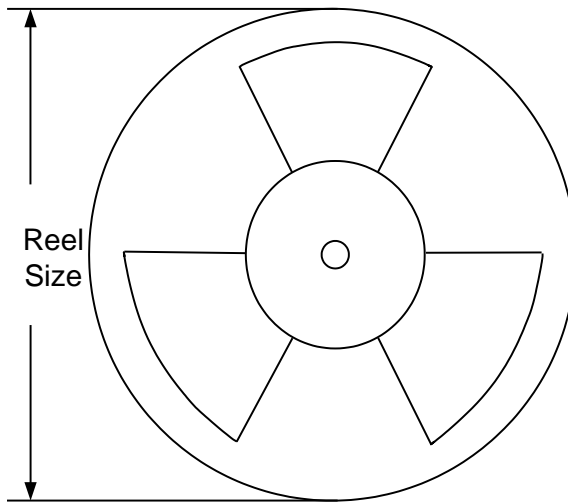

Package type	Tape width (mm)	Pocket pitch(mm)	Reel size (Inch)	Trailer length(mm)	Leader length (mm)	Qty per reel
SO8	12	8	13"	400	400	2500

---

## IMPORTANT NOTICE

- 1. Right to make changes.** Silergy and its subsidiaries (hereafter Silergy) reserve the right to change any information published in this document, including but not limited to circuitry, specification and/or product design, manufacturing or descriptions, at any time and without notice. This document supersedes and replaces all information supplied prior to the publication hereof. Buyers should obtain the latest relevant information before placing orders and should verify that such information is current and complete. All semiconductor products are sold subject to Silergy's standard terms and conditions of sale.
- 2. Applications.** Application examples that are described herein for any of these products are for illustrative purposes only. Silergy makes no representation or warranty that such applications will be suitable for the specified use without further testing or modification. Buyers are responsible for the design and operation of their applications and products using Silergy products. Silergy or its subsidiaries assume no liability for any application assistance or designs of customer products. It is customer's sole responsibility to determine whether the Silergy product is suitable and fit for the customer's applications and products planned. To minimize the risks associated with customer's products and applications, customer should provide adequate design and operating safeguards. Customer represents and agrees that it has all the necessary expertise to create and implement safeguards which anticipate dangerous consequences of failures, monitor failures and their consequences, lessen the likelihood of failures that might cause harm and take appropriate remedial actions. Silergy assumes no liability related to any default, damage, costs or problem in the customer's applications or products, or the application or use by customer's third-party buyers. Customer will fully indemnify Silergy, its subsidiaries, and their representatives against any damages arising out of the use of any Silergy components in safety-critical applications. It is also buyers' sole responsibility to warrant and guarantee that any intellectual property rights of a third party are not infringed upon when integrating Silergy products into any application. Silergy assumes no responsibility for any said applications or for any use of any circuitry other than circuitry entirely embodied in a Silergy product.
- 3. Limited warranty and liability.** Information furnished by Silergy in this document is believed to be accurate and reliable. However, Silergy makes no representation or warranty, expressed or implied, as to the accuracy or completeness of such information and shall have no liability for the consequences of use of such information. In no event shall Silergy be liable for any indirect, incidental, punitive, special or consequential damages, including but not limited to lost profits, lost savings, business interruption, costs related to the removal or replacement of any products or rework charges, whether or not such damages are based on tort or negligence, warranty, breach of contract or any other legal theory. Notwithstanding any damages that customer might incur for any reason whatsoever, Silergy' aggregate and cumulative liability towards customer for the products described herein shall be limited in accordance with the Standard Terms and Conditions of Sale of Silergy.
- 4. Suitability for use.** Customer acknowledges and agrees that it is solely responsible for compliance with all legal, regulatory and safety-related requirements concerning its products, and any use of Silergy components in its applications, notwithstanding any applications-related information or support that may be provided by Silergy. Silergy products are not designed, authorized or warranted to be suitable for use in life support, life-critical or safety-critical systems or equipment, nor in applications where failure or malfunction of an Silergy product can reasonably be expected to result in personal injury, death or severe property or environmental damage. Silergy assumes no liability for inclusion and/or use of Silergy products in such equipment or applications and therefore such inclusion and/or use is at the customer's own risk.
- 5. Terms and conditions of commercial sale.** Silergy products are sold subject to the standard terms and conditions of commercial sale, as published at <http://www.silergy.com/stdterms>, unless otherwise agreed in a valid written individual agreement specifically agreed to in writing by an authorized officer of Silergy. In case an individual agreement is concluded only the terms and conditions of the respective agreement shall apply. Silergy hereby expressly objects to and denies the application of any customer's general terms and conditions with regard to the purchase of Silergy products by the customer.
- 6. No offer to sell or license.** Nothing in this document may be interpreted or construed as an offer to sell products that is open for acceptance or the grant, conveyance or implication of any license under any copyrights, patents or other industrial or intellectual property rights. Silergy makes no representation or warranty that any license, either express or implied, is granted under any patent right, copyright, mask work right, or other intellectual property right. Information published by Silergy regarding third-party products or services does not constitute a license to use such products or services or a warranty or endorsement thereof. Use of such information may require a license from a third party under the patents or other intellectual property of the third party, or a license from Silergy under the patents or other intellectual property of Silergy.

For more information, please visit: [www.silergy.com](http://www.silergy.com)

© 2018 Silergy Corp.

All Rights Reserved.