

General Description

SY59119A1/B1 is a linear LED driver for HV TRIAC with integrated 500V power MOSFET and 700V bleeder MOSFET. It uses special technology to achieve high PF and efficiency performance. Special logic functions are added to achieve good compatibility with TRIAC dimmer.

Ordering Information

SY59119□(□□)□

- Temperature Code
- Package Code
- Optional Spec Code

Ordering Number	Package type	Note
SY59119A1FCC	SO8E	----
SY59119B1FCC	SO8E	

Features

- Compatible with HV TRIAC Dimmer
- Integrated: 500V Main MOS and 700V Bleeder MOS
- Latching Current is Adjustable
- Special Low Power Loss Control
- High PF: PF>0.7
- No Magnetic Components and Support All Components Surface Mounted
- Compatible with Brazil 60Hz
- RoHS Compliant and Halogen Free
- Compact Package: SO8E

Applications

- LED Lighting

Part Number	Minimum output current
SY59119A1	>16mA
SY59119B1	>12mA

Typical Applications

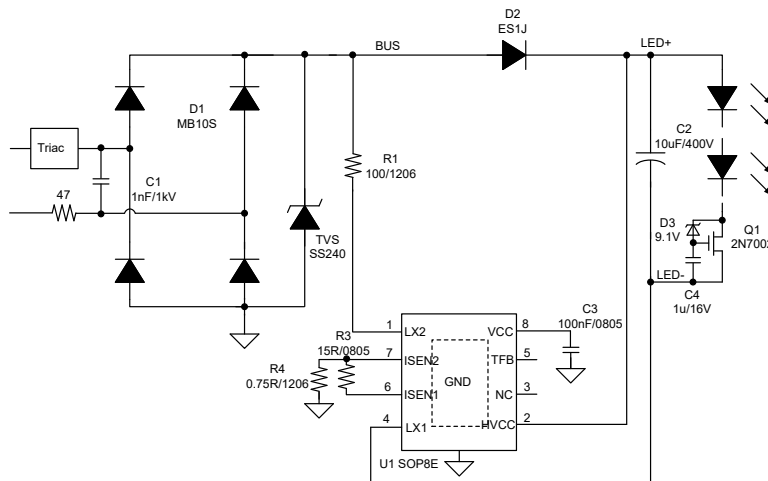
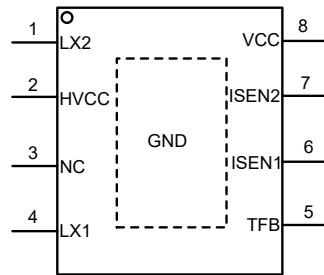

Figure.1 Typical application

Pinout (top view)



(SO8E)

Part Number	Package type	Top Mark [Ⓢ]
SY59119A1FCC	SO8E	DBGxyz
SY59119B1FCC	SO8E	DMNxyz

Note ①: x=year code, y=week code, z=lot number code

Pin Name	Pin number	Pin Description
LX2	1	Drain of Bleeding MOS pin.
HVCC	2	HV power supply pin.
NC	3	No connect.
LX1	4	Drain of Main MOS pin.
TFB	5	Thermal fold back setting pin.
ISEN1	6	Main MOS Current Sense Pin. The output current is decided by $I_{OUT} = \frac{V_{REF}}{R_{ISEN1} + R_{ISEN2}}$
ISEN2	7	BLD MOS Current Sense Pin. Latching current is adjusted by R _{ISEN2} . Recommended value: R _{ISEN2} > 0.7 ohm.
VCC	8	Power supply pin.
GND	9	Ground.

Block Diagram

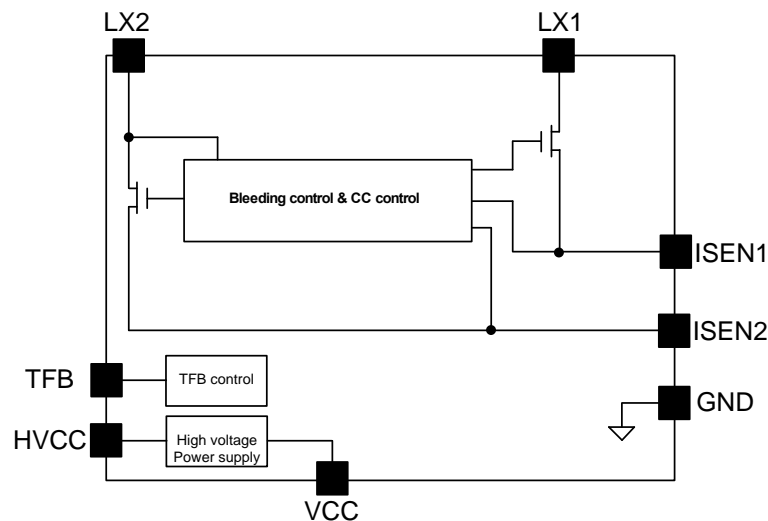

Fig.3 Block Diagram



Absolute Maximum Ratings (Note 1)

LX2, HVCC	-----	-0.3V~700V
LX1	-----	-0.3V~500V
TFB, ISEN1, ISEN2	-----	-0.3V~3.6V
VCC	-----	-0.3~ 22V
Power Dissipation, @ T _A = 25°C SO8E	-----	3.3W
Package Thermal Resistance (Note 2)		
SO8E, θ_{JA}	-----	30°C/W
SO8E, θ_{JC}	-----	10°C/W
Junction Temperature Range	-----	-40°C to 150°C
Lead Temperature (Soldering, 10 sec.)	-----	260°C
Storage Temperature Range	-----	-65°C to 150°C

Recommended Operating Conditions (Note 3)

Junction Temperature Range	-----	-40°C to 150°C
Ambient Temperature Range	-----	-40°C to 120°C

Electrical Characteristics

($V_{IN} = 15V$ (Note 3), $T_A = 25^\circ C$ unless otherwise specified)

Parameter	Symbol	Test Conditions	Min	Typ	Max	Unit
Power Supply Section						
VIN Turn-on Threshold	V_{VIN_ON}		11	12.1	13.2	V
VIN Turn-off Threshold	V_{VIN_OFF}		7.8	8.8	9.8	V
Quiescent Current	I_Q		210	280	350	μA
Error Amplifier Section						
Internal Reference Voltage	V_{REF}		0.291	0.3	0.309	V
MOS Section						
Clamped Current of LX1 MOS	I_{CLP}			32		mA
BV of LX1 MOS	V_{BV_LX1}		500			V
BV of LX2 MOS	V_{BV_LX2}		700			V
Thermal Section						
Minimum Thermal Foldback Temperature	T_{FB1}		105	115	125	$^\circ C$
Maximum Thermal Foldback Temperature	T_{FB2}		145	155	165	$^\circ C$

Note 1: Stresses beyond the “Absolute Maximum Ratings” may cause permanent damage to the device. These are stress ratings only. Functional operation of the device at these or any other conditions beyond those indicated in the operational sections of the specification is not implied. Exposure to absolute maximum rating conditions for extended periods may affect device reliability.

Note 2: Θ_{JA} is measured in the natural convection at $T_A = 25^\circ C$ on a low effective single layer thermal conductivity test board of JEDEC 51-3 thermal measurement standard. Test condition: Device mounted on 2” x 2” FR-4 substrate PCB, 2oz copper, with minimum recommended pad on top layer and thermal vias to bottom layer ground plane.

Note 3: Increase VIN pin voltage gradually higher than V_{VIN_ON} voltage then turn down to 12V.

Operation

SY59119A1/B1 is a HV TRIAC Linear Controller. It recognizes ac mode, leading edge mode, trailing edge mode automatically in first sixteen ac cycles.

For improving the efficiency, the current of LX1 is compensated by VBUS. In the peak voltage of VBUS, the current of LX1 is the smallest, and then the loss is decreased.

In leading edge mode, SY59119A1/B1 controls the fire current automatically which is the Silergy exclusive patent.

For trailing edge dimmer, SY59119A1/B1 has a good performance by Reliable reset control.

TFB is available to be set for different application.

PF is higher than 0.7 suitable for European market.

Applications Information

AC Mode

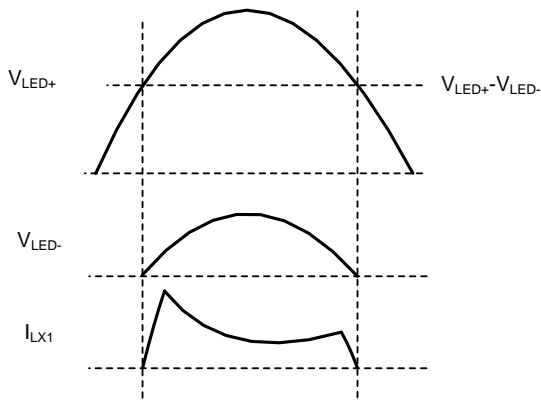

Fig.4 state in ac mode

In ac mode, the wave is showed above. The current of LX1 is compensated by VBUS for good efficiency performance.

In any kinds of mode, the output current is regulated by ISEN1 and ISEN2.

$$I_{OUT} = \frac{V_{REF}}{R_{ISEN1} + R_{ISEN2}}$$

Trailing Edge Mode

In trailing edge mode, SY59119A1/B1 tries to reset the dimmer when the current of LX1 MOS is off. As showed below.

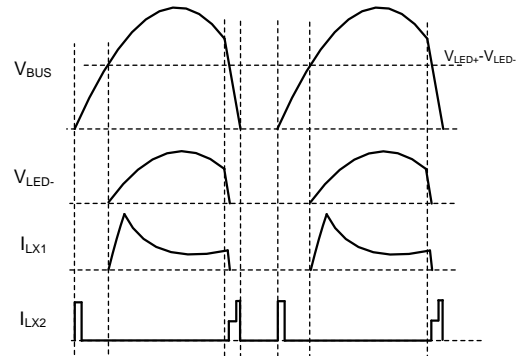

Fig.5 state in trailing edge mode

Trailing Edge Mode

In trailing edge mode, the fire current is decided by the resistor of ISEN2.

With smaller R_{ISEN2} , the latching current of LX2 is larger. For improving the efficiency, recommend to choose larger value of R_{ISEN2} , and satisfy appropriate compatibility.

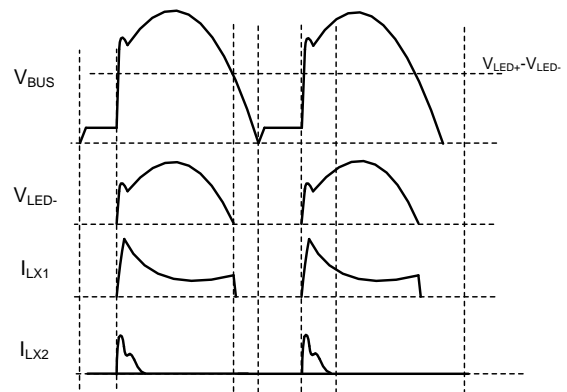

Fig.6 state in leading edge mode

The current of LX1 and LX2 flow through R_{ISEN2} simultaneously. So the actual fire current contains both two currents which help to decrease the fire loss. Recommend value: $R_{ISEN1} > 0.7 \text{ ohm}$.

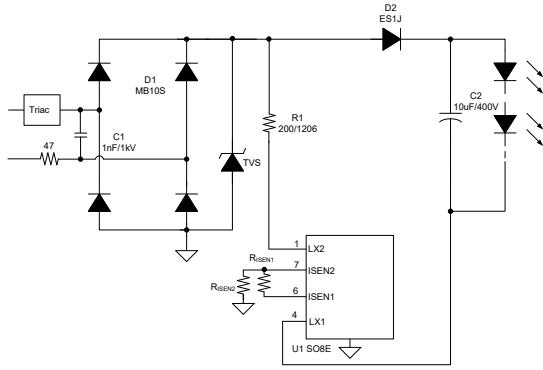

Fig.6 fire current sample resistor

CV Logic

For further improve efficiency, SY59119A1/B1 integrate automatic CV regulation logic. So the loss caused by holding current is reduced.

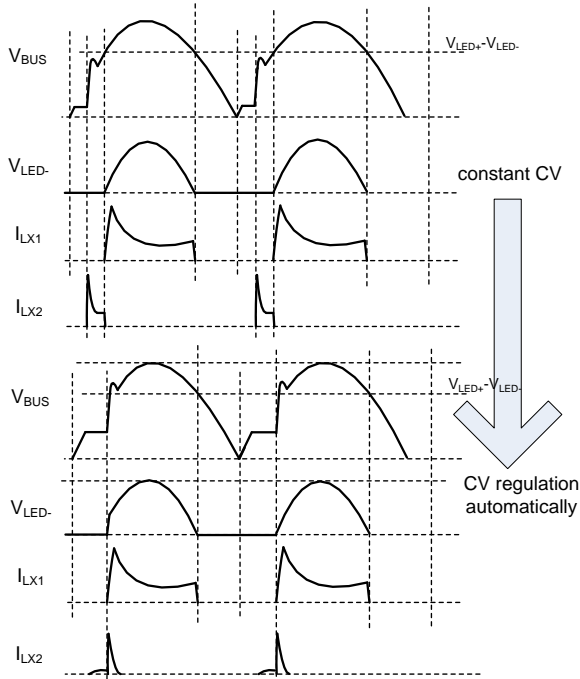

Fig.7 CV logic

TFB setting

TFB is set by TFB pin and controlled by digital logic. So please do not select the value out of list.

RTFB(k ohm)	TFB(°)
NC	155
120	150
56	145
30	140
15	135
7.5	130
3.6	125
1.8	120
0	115

TFB curve is showed as below.

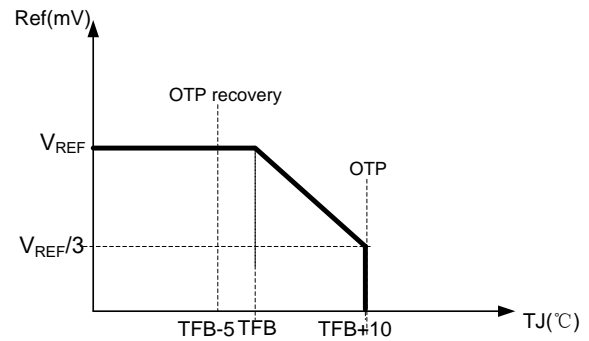

Fig.8 TFB curve

Design Example

A design example of typical application is shown below step by step.

Example A

#1. Identify design specification

Target parameter			
I_{OUT}	22mA	T_{TFB}	150°

#1. Set R_{ISEN1} and R_{ISEN2}

Set $R_{ISEN2}=0.75\text{ ohm}$

$$R_{ISEN1} = \frac{V_{REF}}{I_{OUT}} - R_{ISEN2} = \frac{0.3}{0.022} - 0.75 \approx 13\text{ ohm}$$

#2 set TFB pin

$R_{TFB}=NC$.

#3 final result

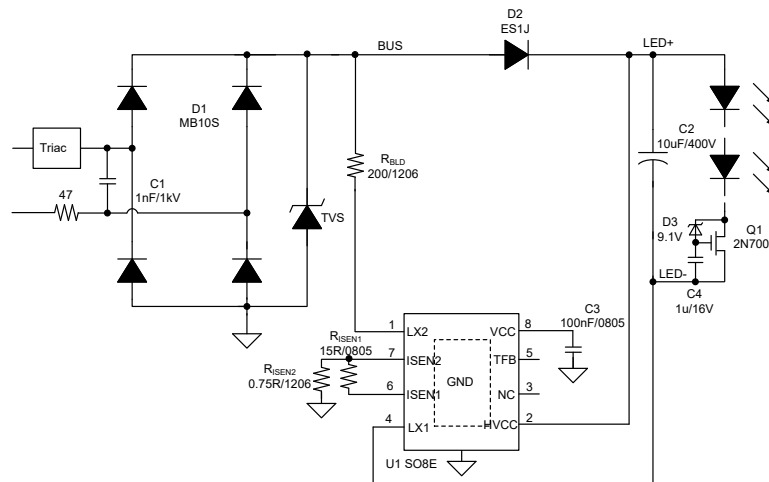
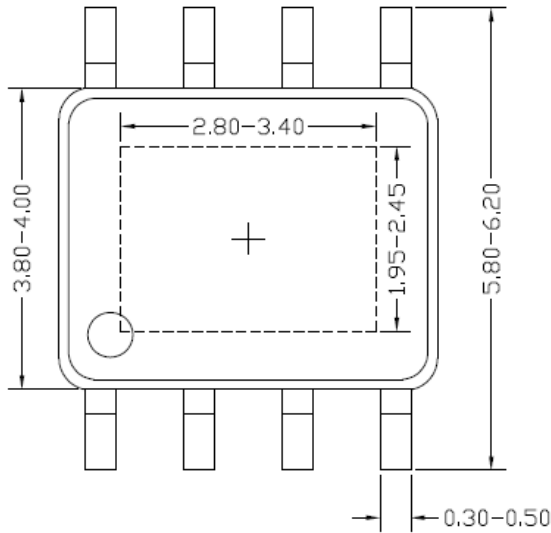
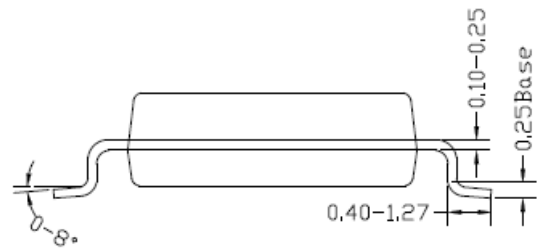

Fig.9 Final Design Result

SO8E Package Outline & PCB layout



Top view



Side view

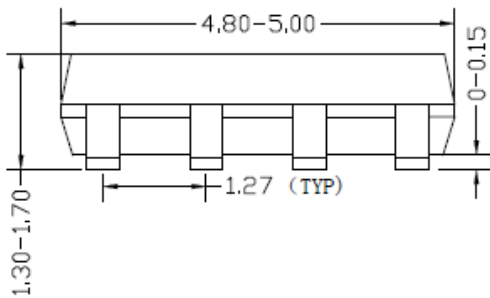

Front view

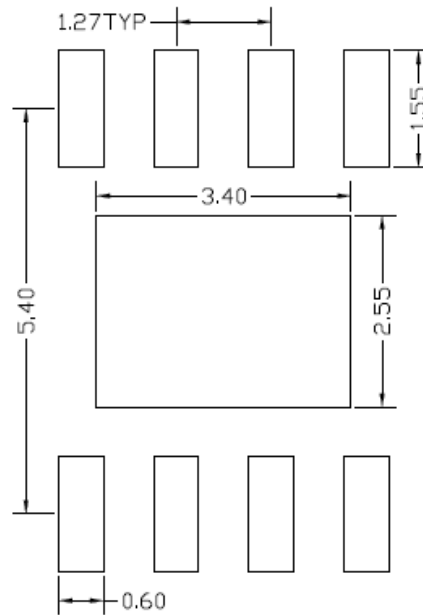

Recommended PCB Layout
(Reference Only)

Notes: All dimension in millimeter and exclude mold flash & metal burr.

Taping & Reel Specification

1. Taping orientation

SO8E

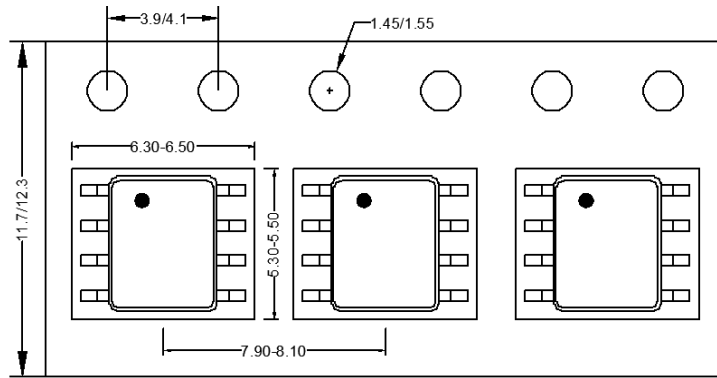

Feeding direction →

2. Carrier Tape & Reel specification for packages

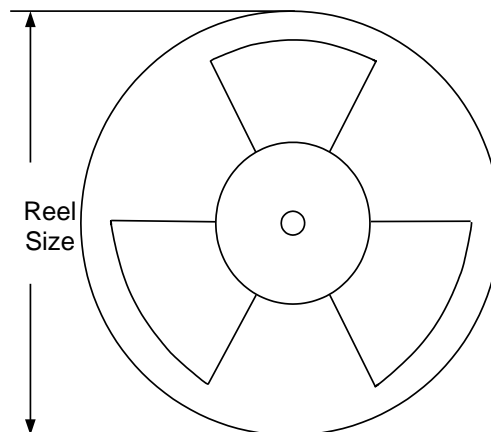

Package types	Tape width (mm)	Pocket pitch(mm)	Reel size (Inch)	Trailer * length(mm)	Leader * length (mm)	Qty per reel (pcs)
SO8E	12	8	13"	400	400	2500

Others: NA