

### General Description

SY6829A integrates an ultra-low  $R_{DS(ON)}$  switch with a dedicated ON pin. It makes SY6829A supporting independent ON/OFF control.

SY6829A features low to 300nA quiescent current at ON state and low to 100nA at shutdown mode. The ultra low current consumption significantly extends battery life time. It makes SY6829A the best selection for IoT application.

### Ordering Information

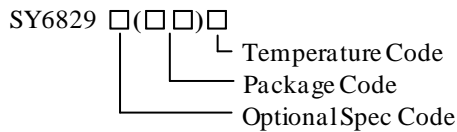

Ordering Number	Package Type	Note
SY6829APRC	CSP0.79×0.79-4	

### Features

- Low  $R_{DS(ON)}$ : 80mΩ
- 1.5A Continuous Load Current Capability
- 300nA Quiescent Current
- 100nA Shutdown Current
- Independent ON/OFF Control Input
- Ultra Compact CSP0.79×0.79-4 0.3mm Thick Package
- RoHS Compliant and Halogen Free

### Applications

- Smart Phone, Tablet PCs
- MID, E-Book
- Storage, DSLR, and Portable Devices

### Typical Applications

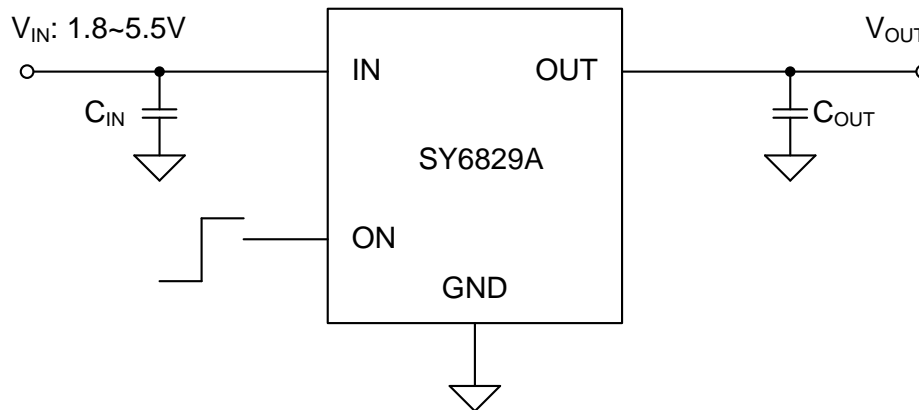
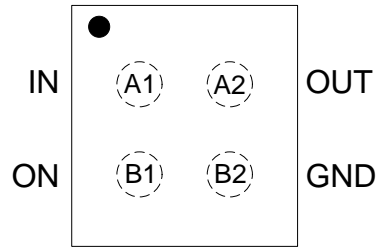

Figure1. Schematic Diagram

## Pinout (top view)



(CSP0.79×0.79-4)

Top Mark: **eRxyz**, (Device code: eR; *x*=year code, *y*=week code, *z*=lot number code)

Pin Name	Pin Number	Pin Description
IN	A1	Input pin. Decouple this pin to GND with at least 4.7μF ceramic cap.
OUT	A2	Output pin. Decouple this pin to GND with at least 4.7μF ceramic cap.
GND	B2	Ground pin.
ON	B1	ON/OFF control. Active high. Do not leave it floating.

## Block Diagram

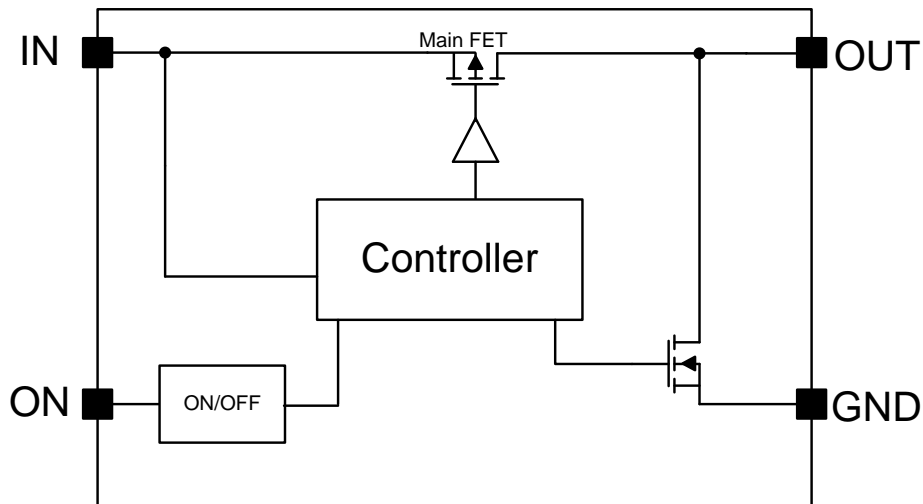

Figure2. Block Diagram



## Absolute Maximum Ratings (Note 1)

IN, OUT, ON	6.0V
Power Dissipation, P <sub>D</sub> @ T <sub>A</sub> = 25°C	0.66W
Package Thermal Resistance (Note 2)	
θ <sub>JA</sub>	188°C/W
θ <sub>JC</sub>	2°C/W
Junction Temperature Range	-40°C to 150°C
Lead Temperature (Soldering, 10 sec.)	260°C
Storage Temperature Range	-65°C to 150°C

## Recommended Operating Conditions (Note 3)

IN	1.8V to 5.5V
ON, OUT	0V to 5.5V
Junction Temperature Range	-40°C to 125°C
Ambient Temperature Range	-40°C to 85°C

## Electrical Characteristics

(V<sub>IN</sub> = 3.3V, T<sub>A</sub> = 25°C unless otherwise specified)

Parameter	Symbol	Test Conditions	Min	Typ	Max	Unit
Input Voltage Range	V <sub>IN</sub>		1.8		5.5	V
Shutdown Current	I <sub>SHDN</sub>	ON=low			100	nA
Quiescent Current	I <sub>Q</sub>	I <sub>OUT</sub> =0			300	nA
FET R <sub>ON</sub>	R <sub>DS(ON)</sub>	V <sub>IN</sub> =5V		80		mΩ
		V <sub>IN</sub> =3.3V		95		mΩ
		V <sub>IN</sub> =1.8V		155		mΩ
Output Voltage Rise Time	t <sub>RISE</sub>	V <sub>IN</sub> =3.3V, measure time V <sub>OUT</sub> rise from 10% of V <sub>IN</sub> to 90% of V <sub>IN</sub>	55	85	115	μs
Turn On Delay Time	t <sub>DELAY</sub>	V <sub>IN</sub> =3.3V, measure time from EN rise edge to 10% of V <sub>IN</sub>	45	75	105	μs
ON Input Logic High	V <sub>IH</sub>		1.0			V
ON Input Logic Low	V <sub>IL</sub>				0.4	V
Output Discharge Resister	R <sub>DIS</sub>	V <sub>IN</sub> =5V, ON=Low		8.5		Ω

**Note 1:** Stresses beyond the “Absolute Maximum Ratings” may cause permanent damage to the device. These are stress ratings only. Functional operation of the device at these or any other conditions beyond those indicated in the operational sections of the specification is not implied. Exposure to absolute maximum rating conditions for extended periods may affect device reliability.

**Note 2:** θ<sub>JA</sub> is measured in the natural convection at T<sub>A</sub> = 25°C on a low effective single layer thermal conductivity test board of JEDEC 51-3 thermal measurement standard.

**Note 3:** The device is not guaranteed to function outside its operating conditions.

## Typical Operating Characteristics

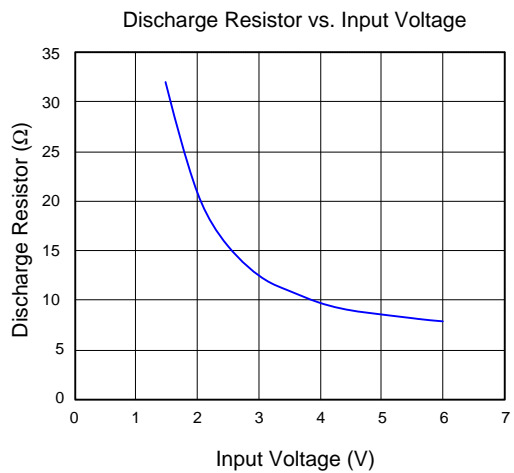
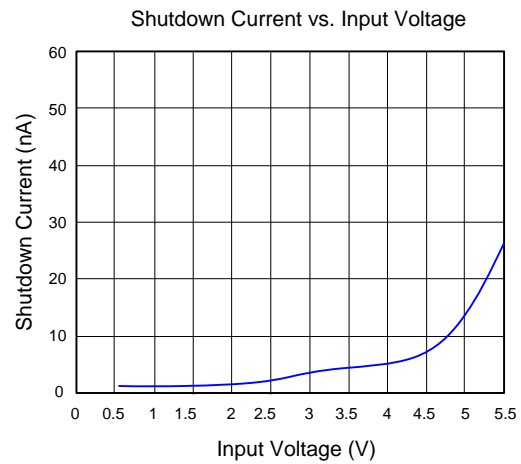
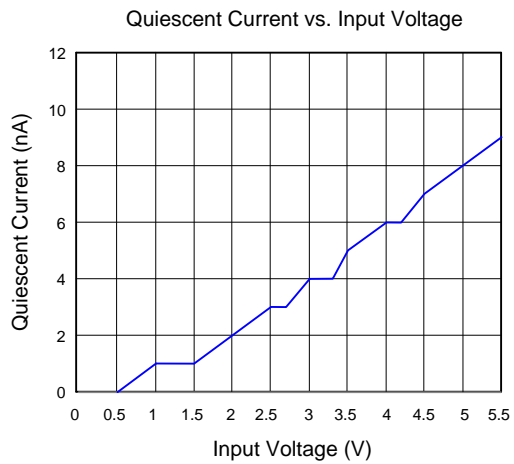
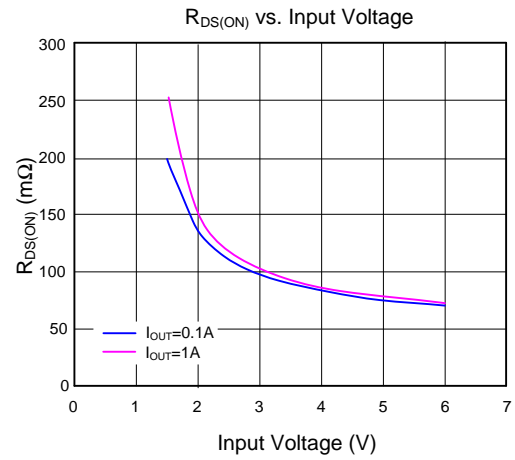
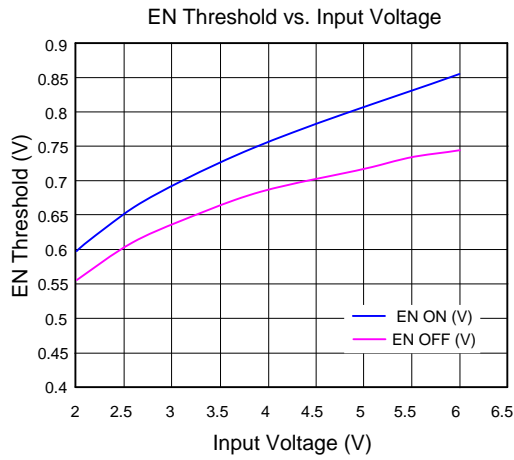

Startup from Enable

( $V_{IN}=3.3V$ ,  $C_{IN}=C_{OUT}=4.7\mu F$ ,  $I_{OUT}=1A$ )

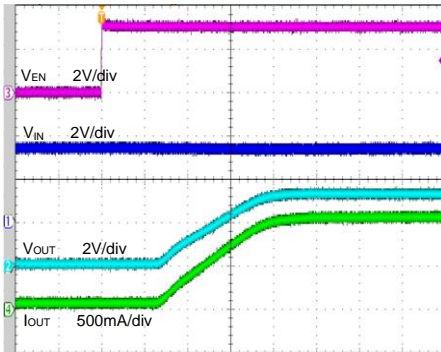

Time (40µs/div)

Shutdown from Enable

( $V_{IN}=3.3V$ ,  $C_{IN}=C_{OUT}=4.7\mu F$ ,  $I_{OUT}=1A$ )

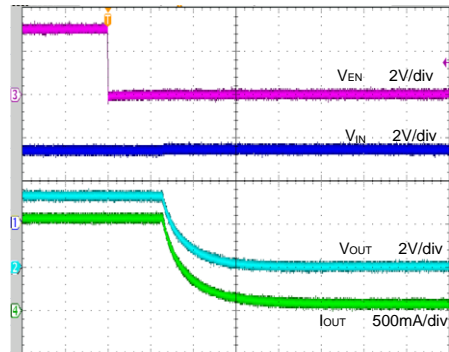

Time (20µs/div)

Startup from  $V_{IN}$

( $V_{IN}=EN=3.3V$ ,  $C_{IN}=C_{OUT}=4.7\mu F$ ,  $I_{OUT}=1A$ )

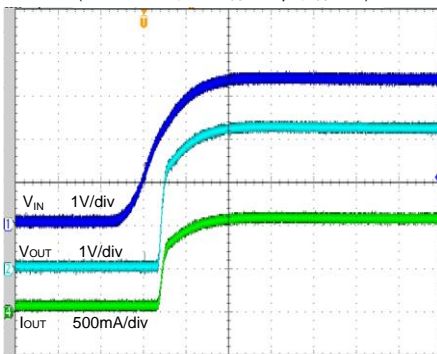

Time (400µs/div)

Shutdown from  $V_{IN}$

( $V_{IN}=EN=3.3V$ ,  $C_{IN}=C_{OUT}=4.7\mu F$ ,  $I_{OUT}=1A$ )

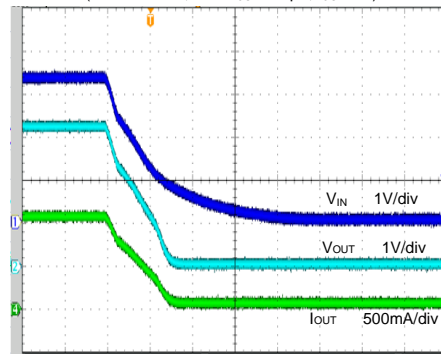

Time (4ms/div)

## Operation Information

SY6829A integrates an ultra-low  $R_{DS(ON)}$  switch with a dedicated ON pin. It makes SY6829A supporting independent ON/OFF control. SY6829A features low to 300nA quiescent current at ON state and low to 100nA at shutdown mode. The ultra low current consumption significantly extends battery life time. It makes SY6829A the best selection for IoT application.

### Input Capacitor $C_{IN}$

To reduce device inrush current, a 4.7 $\mu$ F ceramic capacitor,  $C_{IN}$ , is recommended. A higher value of  $C_{IN}$  can be used to reduce the voltage drop experienced as the switch is turned on into large capacitive load. To minimize the potential noise problem, it is recommended to place  $C_{IN}$  really close to the IN and GND pins.

### Output Capacitor $C_{OUT}$

A 4.7 $\mu$ F ceramic output cap is recommended to prevent

parasitic board inductance from forcing  $V_{OUT}$  below GND when switching off.

### Output Discharge

SY6829A integrates a 8.5 $\Omega$  pull down resistor for quick output discharge. The resistor is activated when the switch is turned off.

### PCB Layout Design

For best performance of the SY6829A, the following guidelines must be strictly followed:

1. Keep all power trace as short and wide as possible. And it is desirable to use 2-layer or 4-layer board for thermal performance and better capability of current flow. These power pins include IN and OUT.
2. Place input capacitor and output capacitor close to the IC for better transient performance.

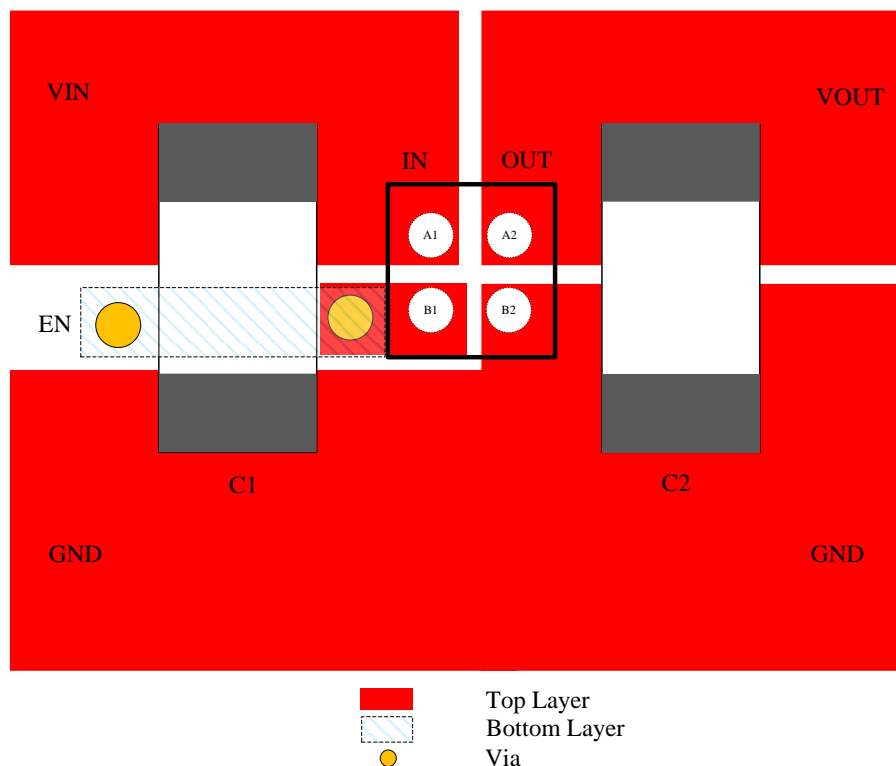
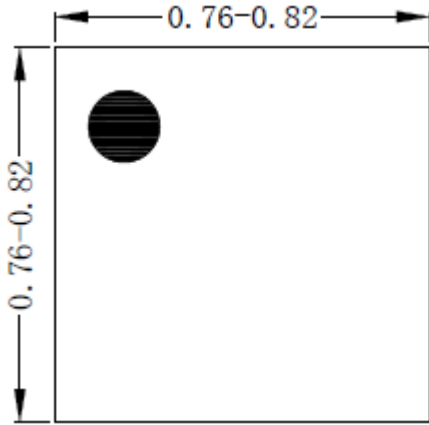
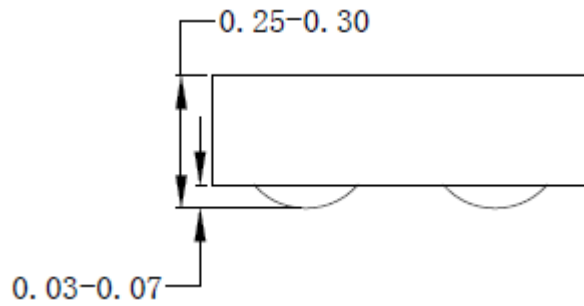

Figure3. PCB Layout Suggestion

**CSP0.79×0.79-4 Package Outline Drawing**



**Top view**



**Side view**

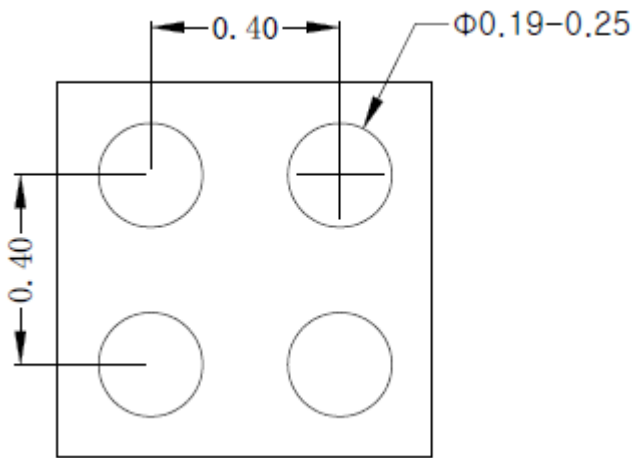

**Bottom view**

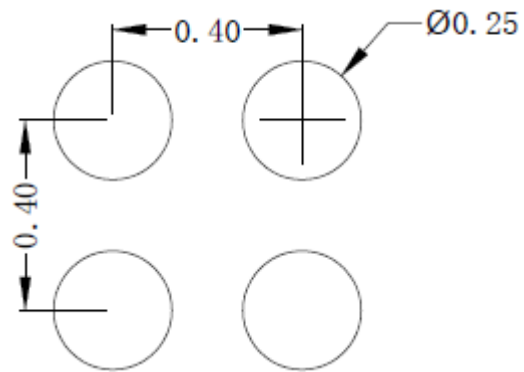

**Recommended PCB layout  
(Reference only)**

**Notes: All dimension in millimeter and exclude mold flash & metal burr**

**Taping & Reel Specification**

**1. CSP0.79×0.79 taping orientation**

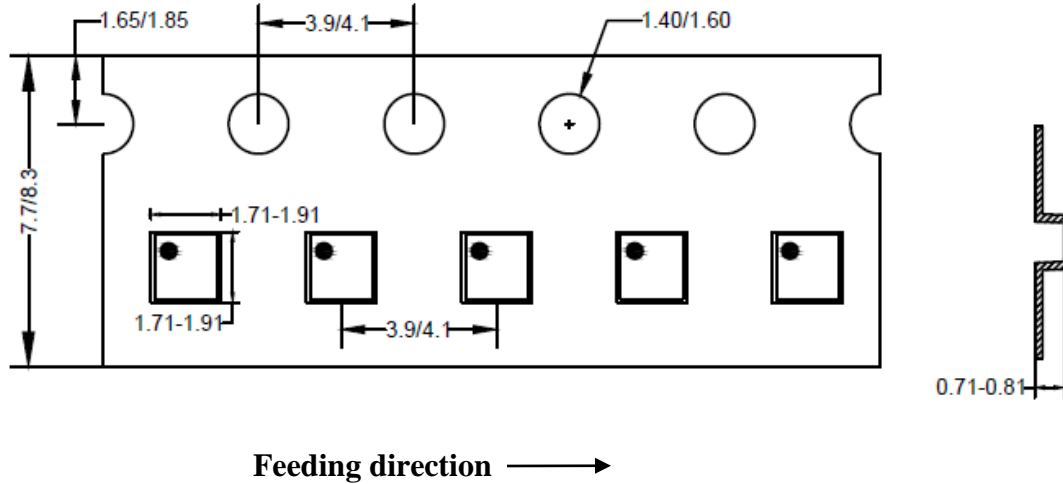

**2. Carrier Tape & Reel specification for packages**

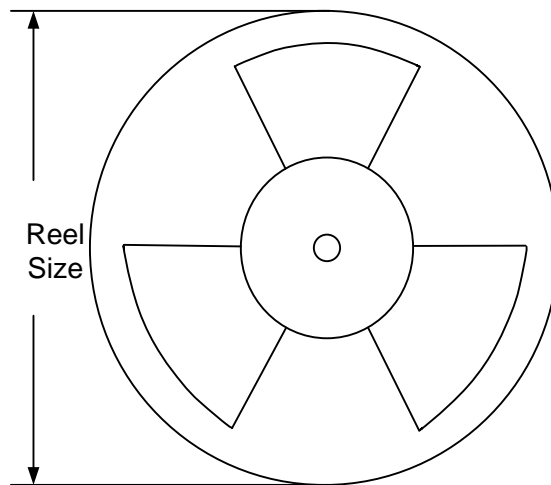

Package type	Tape width (mm)	Pocket pitch(mm)	Reel size (Inch)	Trailer length(mm)	Leader length (mm)	Qty per reel
CSP0.79×0.79	8	4	7"	400	160	10000

**3. Others: NA**



## Revision History

The revision history provided is for informational purpose only and is believed to be accurate, however, not warranted. Please make sure that you have the latest revision.

<b>Date</b>	<b>Revision</b>	<b>Change</b>
Jul.09, 2018	Revision 0.9A	"Features" page1: Change from "1A Continuous Load Current Capability" to "1.5A Continuous Load Current Capability".
Mar.09, 2018	Revision 0.9	Initial Release



## IMPORTANT NOTICE

- 1. Right to make changes.** Silergy and its subsidiaries (hereafter Silergy) reserve the right to change any information published in this document, including but not limited to circuitry, specification and/or product design, manufacturing or descriptions, at any time and without notice. This document supersedes and replaces all information supplied prior to the publication hereof. Buyers should obtain the latest relevant information before placing orders and should verify that such information is current and complete. All semiconductor products are sold subject to Silergy's standard terms and conditions of sale.
- 2. Applications.** Application examples that are described herein for any of these products are for illustrative purposes only. Silergy makes no representation or warranty that such applications will be suitable for the specified use without further testing or modification. Buyers are responsible for the design and operation of their applications and products using Silergy products. Silergy or its subsidiaries assume no liability for any application assistance or designs of customer products. It is customer's sole responsibility to determine whether the Silergy product is suitable and fit for the customer's applications and products planned. To minimize the risks associated with customer's products and applications, customer should provide adequate design and operating safeguards. Customer represents and agrees that it has all the necessary expertise to create and implement safeguards which anticipate dangerous consequences of failures, monitor failures and their consequences, lessen the likelihood of failures that might cause harm and take appropriate remedial actions. Silergy assumes no liability related to any default, damage, costs or problem in the customer's applications or products, or the application or use by customer's third-party buyers. Customer will fully indemnify Silergy, its subsidiaries, and their representatives against any damages arising out of the use of any Silergy components in safety-critical applications. It is also buyers' sole responsibility to warrant and guarantee that any intellectual property rights of a third party are not infringed upon when integrating Silergy products into any application. Silergy assumes no responsibility for any said applications or for any use of any circuitry other than circuitry entirely embodied in a Silergy product.
- 3. Limited warranty and liability.** Information furnished by Silergy in this document is believed to be accurate and reliable. However, Silergy makes no representation or warranty, expressed or implied, as to the accuracy or completeness of such information and shall have no liability for the consequences of use of such information. In no event shall Silergy be liable for any indirect, incidental, punitive, special or consequential damages, including but not limited to lost profits, lost savings, business interruption, costs related to the removal or replacement of any products or rework charges, whether or not such damages are based on tort or negligence, warranty, breach of contract or any other legal theory. Notwithstanding any damages that customer might incur for any reason whatsoever, Silergy' aggregate and cumulative liability towards customer for the products described herein shall be limited in accordance with the Standard Terms and Conditions of Sale of Silergy.
- 4. Suitability for use.** Customer acknowledges and agrees that it is solely responsible for compliance with all legal, regulatory and safety-related requirements concerning its products, and any use of Silergy components in its applications, notwithstanding any applications-related information or support that may be provided by Silergy. Silergy products are not designed, authorized or warranted to be suitable for use in life support, life-critical or safety-critical systems or equipment, nor in applications where failure or malfunction of an Silergy product can reasonably be expected to result in personal injury, death or severe property or environmental damage. Silergy assumes no liability for inclusion and/or use of Silergy products in such equipment or applications and therefore such inclusion and/or use is at the customer's own risk.
- 5. Terms and conditions of commercial sale.** Silergy products are sold subject to the standard terms and conditions of commercial sale, as published at <http://www.silergy.com/stdterms>, unless otherwise agreed in a valid written individual agreement specifically agreed to in writing by an authorized officer of Silergy. In case an individual agreement is concluded only the terms and conditions of the respective agreement shall apply. Silergy hereby expressly objects to and denies the application of any customer's general terms and conditions with regard to the purchase of Silergy products by the customer.
- 6. No offer to sell or license.** Nothing in this document may be interpreted or construed as an offer to sell products that is open for acceptance or the grant, conveyance or implication of any license under any copyrights, patents or other industrial or intellectual property rights. Silergy makes no representation or warranty that any license, either express or implied, is granted under any patent right, copyright, mask work right, or other intellectual property right. Information published by Silergy regarding third-party products or services does not constitute a license to use such products or services or a warranty or endorsement thereof. Use of such information may require a license from a third party under the patents or other intellectual property of the third party, or a license from Silergy under the patents or other intellectual property of Silergy.

For more information, please visit: [www.silergy.com](http://www.silergy.com)

© 2018 Silergy Corp.

All Rights Reserved.