

## Current Limit Switch with Output Voltage Clamping

### General Description

The SQ24815B is a current limit switch with input voltage range selection and output voltage clamping. Extremely low  $R_{DS(ON)}$  of the integrated protection N-channel FET helps to reduce the power loss during the normal operation. Programmable soft-start time controls the slew rate of the output voltage during start-up. Independent enable control allows the complicated system sequencing control. It integrates the over-temperature protection shutdown and the auto-recovery with hysteresis. This IC along with small DFN3×3-10 footprint provides small PCB area application.

### Ordering Information

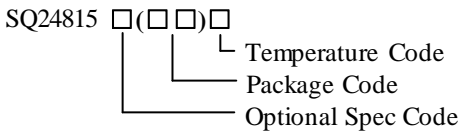

| Ordering Number | Package type | Note |
|-----------------|--------------|------|
| SQ24815BDDB     | DFN3×3-10    | ---- |

### Features

- Wide Input Voltage Range from 2.5V to 6.5V with Surge up to 18V
- Ultra Low Bias Current: 50μA Typical
- Extremely Low  $R_{DS(ON)}$  for the Integrated Protection Switch: 40mΩ
- Programmable Soft-start Time
- 2 Level Current Limit:
  - 1.4A for 3.3 Mode
  - 2.75A for 5V Mode
- Short Circuit Protection
- Selectable Input and Clamping Voltage Range
- Enable Interface Pin
- Thermal Shutdown Protection & Auto Recovery
- RoHS Compliant and Halogen Free
- Compact Package: DFN3×3-10

### Applications

- Notebook PC
- I-pad Mini
- Server
- Service PC

### Typical Applications

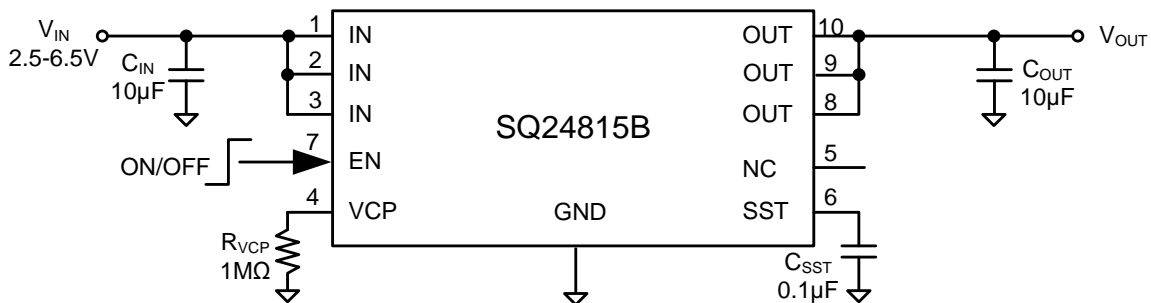
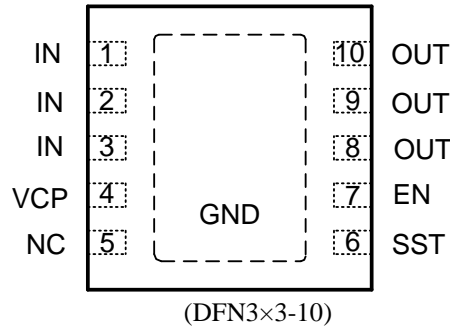

Figure1. Schematic Diagram

## Pinout (top view)



Top mark: **CLTxyz**(Device code: CLT, *x=year code, y=week code, z=lot number code*)

| Pin Name | Pin Number             | Pin Description   |      |      |      |                    |  |  |     |     |     |     |      |         |      |      |      |      |    |         |      |      |      |
|----------|------------------------|---|------|------|------|--------------------|--|--|-----|-----|-----|-----|------|---------|------|------|------|------|----|---------|------|------|------|
| IN       | 1, 2, 3                | Power input pin. Decouple high frequency noise by connecting at least 0.1μF MLCC to ground.   |      |      |      |                    |  |  |     |     |     |     |      |         |      |      |      |      |    |         |      |      |      |
| VCP      | 4                      | Output clamp voltage selection based on the input voltage. Pull VCP pin to high by connecting a resistor to IN, or pull VCP pin to low by connecting a resistor to ground. Recommend to decouple this pin with a 0.1μF capacitor. <table border="1" style="margin: 10px auto;"> <thead> <tr> <th rowspan="2">VCP</th> <th colspan="2" rowspan="2">IN</th> <th colspan="3">Clamping Threshold</th> </tr> <tr> <th>Min</th> <th>Typ</th> <th>Max</th> </tr> </thead> <tbody> <tr> <td>Low</td> <td>3.3V</td> <td>Over 4V</td> <td>3.6V</td> <td>3.8V</td> <td>4.0V</td> </tr> <tr> <td>High</td> <td>5V</td> <td>Over 6V</td> <td>5.4V</td> <td>5.7V</td> <td>6.0V</td> </tr> </tbody> </table> | VCP  | IN   |      | Clamping Threshold |  |  | Min | Typ | Max | Low | 3.3V | Over 4V | 3.6V | 3.8V | 4.0V | High | 5V | Over 6V | 5.4V | 5.7V | 6.0V |
| VCP      | IN                     |   |      |      |      | Clamping Threshold |  |  |     |     |     |     |      |         |      |      |      |      |    |         |      |      |      |
|          |                        |   | Min  | Typ  | Max  |                    |  |  |     |     |     |     |      |         |      |      |      |      |    |         |      |      |      |
| Low      | 3.3V                   | Over 4V   | 3.6V | 3.8V | 4.0V |                    |  |  |     |     |     |     |      |         |      |      |      |      |    |         |      |      |      |
| High     | 5V                     | Over 6V   | 5.4V | 5.7V | 6.0V |                    |  |  |     |     |     |     |      |         |      |      |      |      |    |         |      |      |      |
| NC       | 5                      | No connection.  |      |      |      |                    |  |  |     |     |     |     |      |         |      |      |      |      |    |         |      |      |      |
| SST      | 6                      | Soft-start time program pin. Connect a capacitor to ground to program the soft-start time.  |      |      |      |                    |  |  |     |     |     |     |      |         |      |      |      |      |    |         |      |      |      |
| EN       | 7                      | Enable control input. Pull it high to enable the IC.  |      |      |      |                    |  |  |     |     |     |     |      |         |      |      |      |      |    |         |      |      |      |
| OUT      | 8, 9, 10               | Power output pin.   |      |      |      |                    |  |  |     |     |     |     |      |         |      |      |      |      |    |         |      |      |      |
| GND      | 11<br>(exposed paddle) | Ground pin.   |      |      |      |                    |  |  |     |     |     |     |      |         |      |      |      |      |    |         |      |      |      |

## Block Diagram

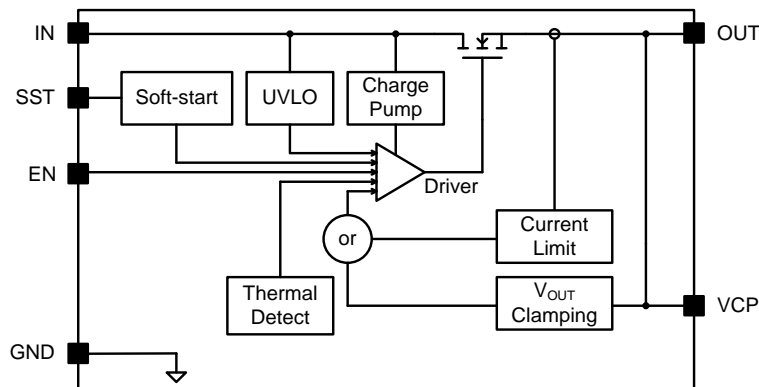



**Absolute Maximum Ratings** (Note 1)

|  |                |
|--|----------------|
| IN, OUT, EN, VCP   | -0.3V to 18V   |
| SST  | -0.3V to 3.6V  |
| Power Dissipation, P <sub>D</sub> @ T <sub>A</sub> = 25°C DFN3×3-10, | 2.6W           |
| Package Thermal Resistance (Note 2)                                  |                |
| θ <sub>JA</sub>  | 38°C/W         |
| θ <sub>JC</sub>  | 8°C/W          |
| Junction Temperature Range   | -40°C to 125°C |
| Lead Temperature (Soldering, 10 sec.)                                | 260°C          |
| Storage Temperature Range  | -65°C to 150°C |

**Recommended Operating Conditions** (Note 3)

|                            |                |
|----------------------------|----------------|
| IN                         | 2.5V to 6.5V   |
| OUT, EN, VCP               | 0V to 6.5V     |
| SST                        | 0V to 3.3V     |
| Junction Temperature Range | -40°C to 125°C |
| Ambient Temperature Range  | -40°C to 85°C  |



### Electrical Characteristics

( $V_{IN} = 5V$ ,  $C_{SST} = 100nF$ ,  $C_{IN} = 10\mu F$ ,  $C_{OUT} = 10\mu F$ ,  $T_A = 25^\circ C$ , unless otherwise specified)

| Parameter                              | Symbol         | Test Conditions                                | Min     | Typ        | Max   | Unit       |   |
|--|----------------|--|---------|------------|-------|------------|---|
| Input Voltage Range                    | $V_{IN}$       |  | 2.5     |            | 6.5   | V          |   |
| Input UVLO Threshold                   | $V_{UVLO}$     | VCP=Low  | Falling | 2.05       |       | 2.35       | V |
|  |                |  | Rising  | 2.2        |       | 2.4        |   |
|  |                | VCP=High                                       | Falling | 3.25       |       | 3.75       | V |
|  |                |  | Rising  | 3.4        |       | 3.8        |   |
| Bias Current                           | $I_{BIAS}$     |  |         | 50         | 65    | $\mu A$    |   |
| Shutdown Current                       | $I_{SHDN}$     | EN=0   |         | 10         |       | $\mu A$    |   |
| Protection FET $R_{ON}$                | $R_{DS(ON)}$   |  |         | 40         | 60    | m $\Omega$ |   |
| Current Limit Threshold                | $I_{LIM}$      | VCP=Low  | 0.63    | 1.4        | 2.17  | A          |   |
|  |                | VCP=High                                       | 1.925   | 2.75       | 3.575 | A          |   |
| Fast Current Limit Response (Note 5)   | $t_{FST\_LIM}$ | $I_{OUT} = 10A/\mu s$                          |         | 2.5        |       | $\mu s$    |   |
| Clamping Output Voltage                | $V_{CLP}$      | VCP=Low  | 3.6     | 3.8        | 4.0   | V          |   |
|  |                | VCP=High                                       | 5.4     | 5.7        | 6.0   | V          |   |
| Output Clamping Response Time (Note 5) | $t_{CLP}$      | VCP=Low,<br>$V_{IN}$ slew rate 0.15V/ $\mu s$  |         | 100        |       | $\mu s$    |   |
|  |                | VCP=High,<br>$V_{IN}$ slew rate 0.15V/ $\mu s$ |         | 100        |       | $\mu s$    |   |
| Soft-start Time                        | $t_{SST}$      | $C_{SST} = 100nF$ (Note 4)                     |         | 23         |       | ms         |   |
| Soft-start Time Accuracy               |                |  |         | $\pm 30\%$ |       | $t_{SST}$  |   |
| EN Turn-on Threshold                   | $V_{EN\_ON}$   |  | 2       |            |       | V          |   |
| EN Turn-off Threshold                  | $V_{EN\_OFF}$  |  |         |            | 0.4   | V          |   |
| Capacitance Load Capability (Note 5)   | $C_{OUT}$      | $V_{IN} = 5V$ , VCP=High, null load            |         |            | 1000  | $\mu F$    |   |
| Thermal Shutdown Temperature           | $T_{SD}$       |  |         | 140        |       | $^\circ C$ |   |
| Thermal Shutdown Hysteresis            | $T_{HYS}$      |  |         | 20         |       | $^\circ C$ |   |

**Note 1:** Stresses beyond the “Absolute Maximum Ratings” may cause permanent damage to the device. These are stress ratings only. Functional operation of the device at these or any other conditions beyond those indicated in the operational sections of the specification is not implied. Exposure to absolute maximum rating conditions for extended periods may affect device reliability

**Note 2:**  $\theta_{JA}$  is measured in the natural convection at  $T_A = 25^\circ C$  on a low effective single layer thermal conductivity test board of JEDEC 51-3 thermal measurement standard. Paddle of DFN3x3-10 packages is the case position for  $\theta_{JC}$  measurement.

**Note 3:** The device is not guaranteed to function outside its operating conditions.

**Note 4:** Recommended Soft-start Time Program Table

|                     |      |     |      |     |
|---------------------|------|-----|------|-----|
| SST Capacitance(nF) | None | 10  | 47   | 100 |
| Rise time (ms)      | 0.6  | 2.3 | 10.8 | 23  |



Recommended formula for  $C_{SST}$  & soft-start time calculation

$$t_{SS} = \begin{cases} t_{SS\_DLT}, \text{ no external } C_{SST} \\ \frac{0.85 \times C_{SST}}{I_{INT}}, t_{SS} > t_{SS\_DLT} \end{cases}$$

Where,  $t_{SS\_DLT}$  is the internally fixed default soft-start time, about 0.6ms, which means there's no any external  $C_{SST}$ ;  $I_{INT}$  is the internal current source, about 3.7 $\mu$ A. The soft-start time tolerance for all condition is  $\pm 50\%$ .

**Note 5:** Guaranteed by design.

## Typical Performance Characteristics

Quiescent Current vs. Input Voltage  
(EN=3V C<sub>IN</sub>=C<sub>OUT</sub>=10uF)

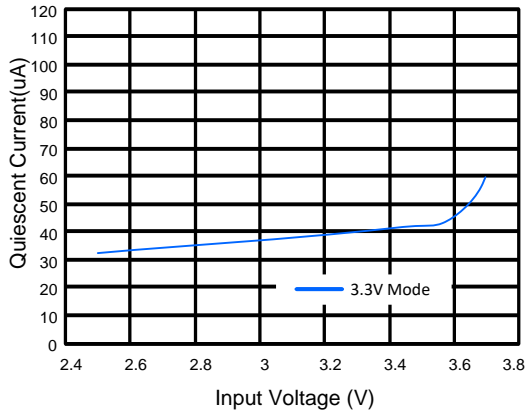

Quiescent Current vs. Input Voltage  
(EN=3V C<sub>IN</sub>=C<sub>OUT</sub>=10uF)

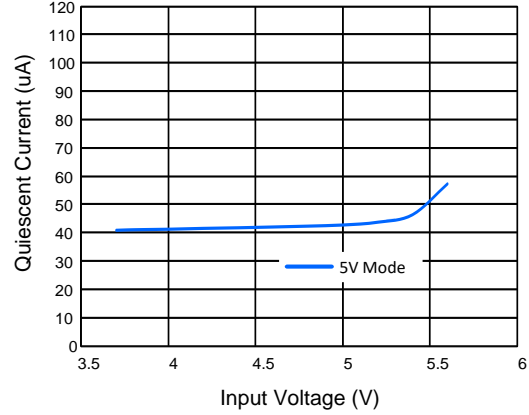

Shutdown Current vs. Input Voltage  
(EN=0V C<sub>IN</sub>=C<sub>OUT</sub>=10uF)

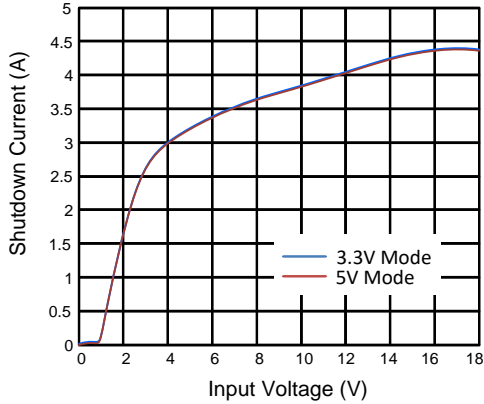

Start Up from VIN  
(3.3V Mode (VCP Low), V<sub>IN</sub>=3.3V, EN=3V R<sub>LOAD</sub>=6.6Ω)

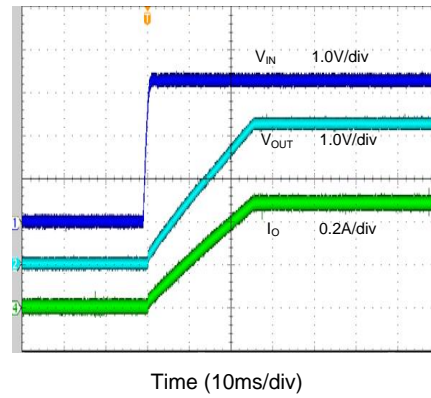

Shut Down from VIN  
(3.3V Mode (VCP Low), V<sub>IN</sub>=3.3V, EN=3V R<sub>LOAD</sub>=6.6Ω)

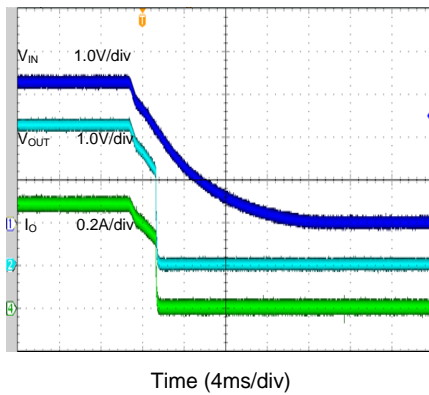

Start Up from VIN  
(5V Mode (VCP High), V<sub>IN</sub>=5V, EN=3V R<sub>LOAD</sub>=5Ω)

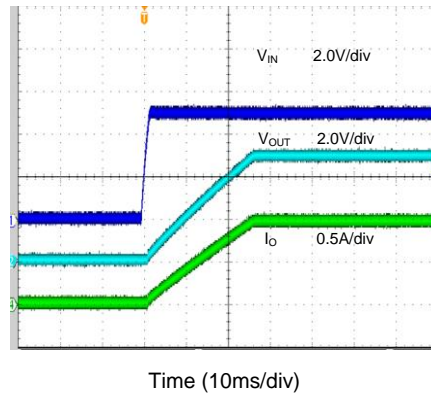

### Shut Down from VIN

(5V Mode (VCP High),  $V_{IN}=5V$ ,  $EN=3V$   $R_{LOAD}=5\Omega$ )

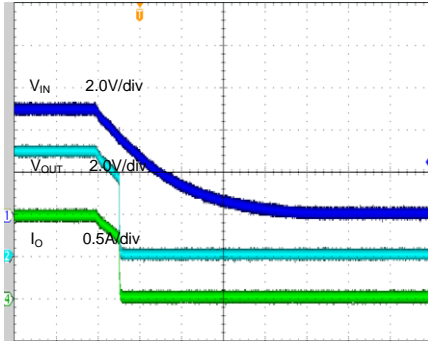

Time (4ms/div)

### Start Up from EN

(3.3V Mode (VCP Low),  $V_{IN}=3.3V$ ,  $EN=3V$   $R_{LOAD}=6.6\Omega$ )

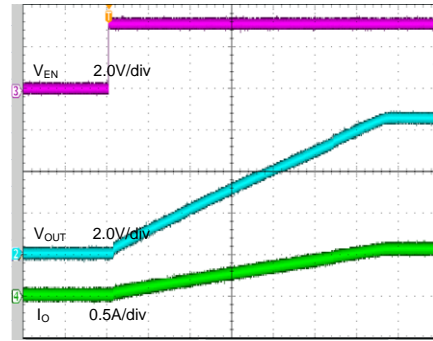

Time (4ms/div)

### Shutdown from EN

(3.3V Mode (VCP Low),  $V_{IN}=3.3V$ ,  $EN=3V$   $R_{LOAD}=6.6\Omega$ )

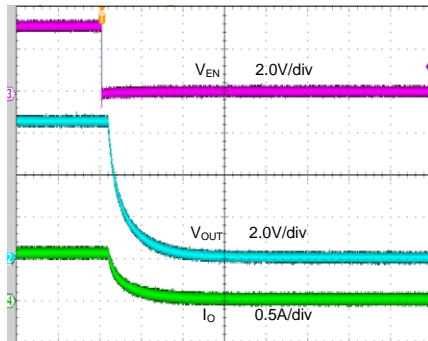

Time (100us/div)

### Start Up from EN

(5V Mode (VCP High),  $V_{IN}=5V$ ,  $EN=3V$   $R_{LOAD}=5\Omega$ )

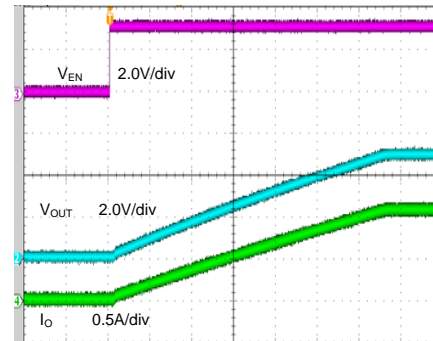

Time (4ms/div)

### Shutdown from EN

(5V Mode (VCP High),  $V_{IN}=5V$ ,  $EN=3V$   $R_{LOAD}=5\Omega$ )

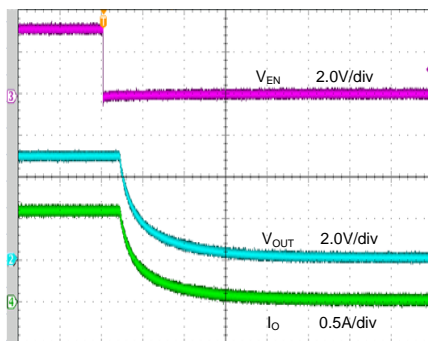

Time (40us/div)

### Clamping Output Voltage Test

3.3V Mode (VCP Low),  $V_{IN}=0-8-0V$ ,  $EN=3V$   $R_{LOAD}=OPEN$

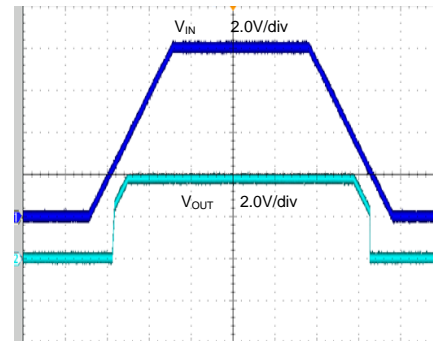

Time (400ms/div)

### Clamping Output Voltage Test

5V Mode (VCP High),  $V_{IN}=0-8-0V$ ,  $EN=3V$   $R_{LOAD}=OPEN$

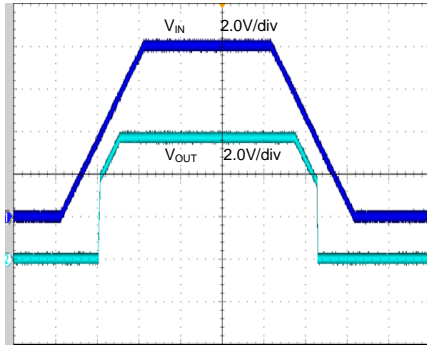

Time (400ms/div)

### Short Test

3.3V Mode (VCP Low),  $V_{IN}=3.3V$ ,  $EN=3V$   
open to short, short to open

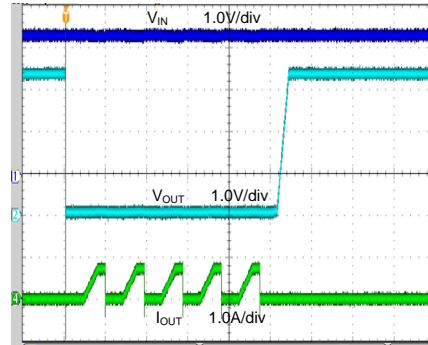

Time (100ms/div)

### Short Test

5V Mode (VCP High),  $V_{IN}=5V$ ,  $EN=3V$   
open to short, short to open

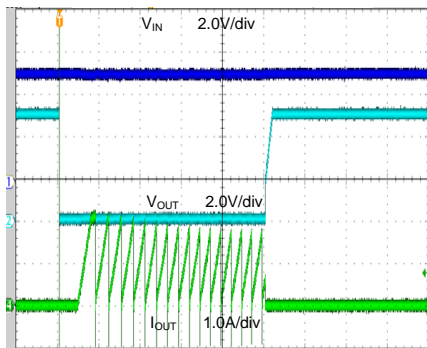

Time (100ms/div)

### Program Soft-start Time

( $EN=3V$   $R_{LOAD}=Open$ )

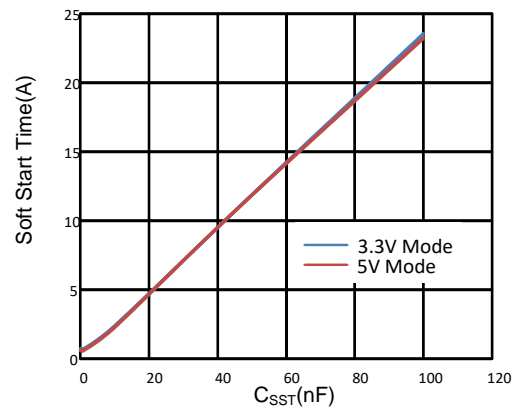

## Applications Information

SQ24815B is a current limit switch with input voltage range selection and output voltage clamping. Extremely low  $R_{DS(ON)}$  of the integrated protection N-channel FET helps to reduce the power loss during the normal operation. Programmable soft-start time controls the slew rate of the output voltage during start-up. Independent enable control allows the complicated system sequencing control. It integrates the over-temperature protection shutdown and the auto-recovery with hysteresis. This IC along with small DFN3×3-10 footprint provides small PCB area application.

### Input Pin

In order to prevent the input voltage drooping during hot-plug events, a 0.1μF ceramic capacitors from VIN to GND is strongly recommended. However, higher capacitor values could reduce the voltage droop on the input further. Furthermore, an output short will cause ringing on the input without the input capacitor. It could destroy the internal circuitry when the input transient exceeds the absolute maximum supply voltage even for a short duration.

### Soft start Time Program

Recommended Current Soft-start Time Program Table

| SST Cap (nF) | None | 10  | 47   | 100 |
|--------------|------|-----|------|-----|
| Rise (ms)    | 0.6  | 2.3 | 10.8 | 23  |

Recommended Formula for CSS & Soft-start slew rate Calculation:

$$t_{SS} = \begin{cases} t_{SS\_DLT}, \text{no external } C_{SST} \\ \frac{0.85 \times C_{SST}}{I_{INT}}, t_{SS} > t_{SS\_DLT} \end{cases}$$

Where,  $t_{SS\_DLT}$  is the internally fixed default soft-start time, about 0.6ms, which means there's no any external  $C_{SST}$ ;  $I_{INT}$  is the internal current source, about 3.7μA.

### Output Pin

A 10μF output ceramic capacitor is recommended to be placed close to the IC and output connector to reduce voltage drop during load transient. Higher values of output capacitor can be used for further reducing the voltage drop during high current application.

### Enable Function

The SQ24815B has the enable pin EN that can be used to enable or disable the device. Pull down the EN pin to disable the device and the Power FET is turned off. Pull up the EN pin to enable the device and turn on the Power FET if there's no any protection occurring.

### Output Clamp Voltage Pin

The SQ24815B Output clamp voltage selection based on the input voltage. Pull VCP pin to high by connecting a resistor to IN, or pull VCP pin to low by connecting a resistor to ground.

| VCP  | IN   |         | Clamping Threshold |      |      |
|------|------|---------|--------------------|------|------|
|      |      |         | Min                | Typ  | Max  |
| Low  | 3.3V | Over 4V | 3.6V               | 3.8V | 4.0V |
| High | 5V   | Over 6V | 5.4V               | 5.7V | 6.0V |

### PCB Layout Guide

For best performance of the SQ24815B, the following guidelines must be strictly followed:

1. Keep all power traces as short and wide as possible and use at least 2 ounce copper for all power traces.
2. Place a ground plane under all circuitry to lower both resistance and inductance and improve DC and transient performance.
3. Locate the output capacitors as close to the connectors as possible to lower the impedance (mainly inductance) between the port and the capacitor and improve transient performance.
4. Input and output capacitors should be placed closed to the IC and connected to ground plane to reduce noise coupling.

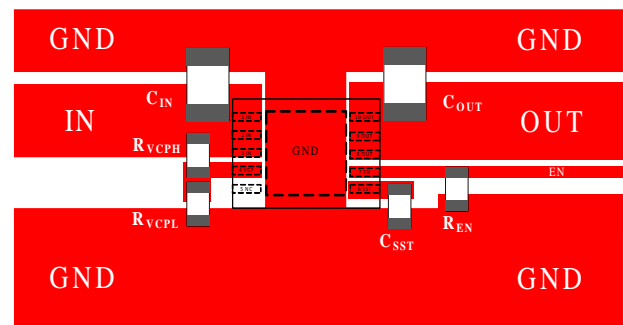
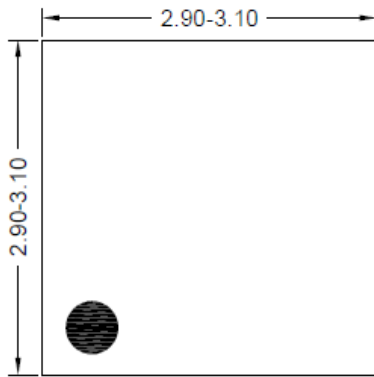
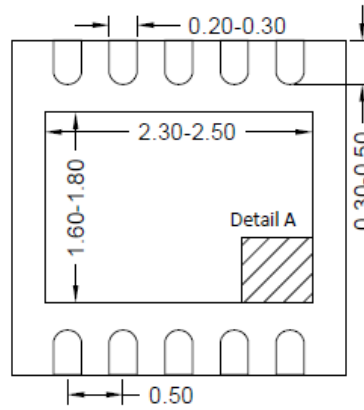

Figure 2. PCB Layout Suggestion

## DFN3×3-10 Package Outline



**Top View**



**Bottom View**

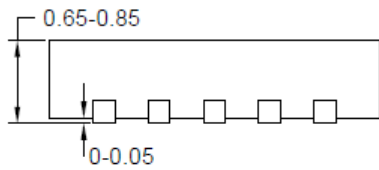
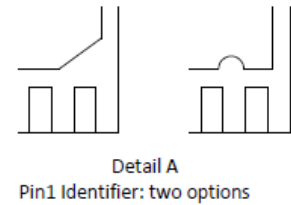

**Side View**

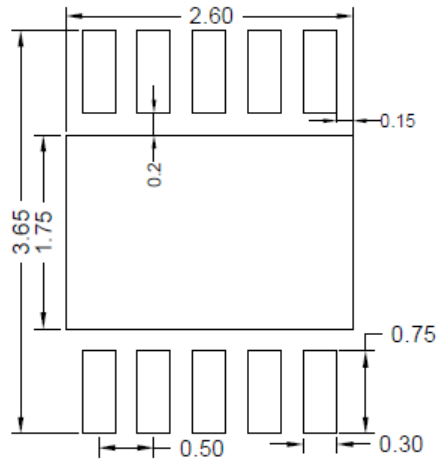

**PCB Layout (recommended)**

**Notes: All dimension in millimeter and exclude mold flash & metal burr.**

## Taping & Reel Specification

### 1. Taping orientation

DFN3×3-10

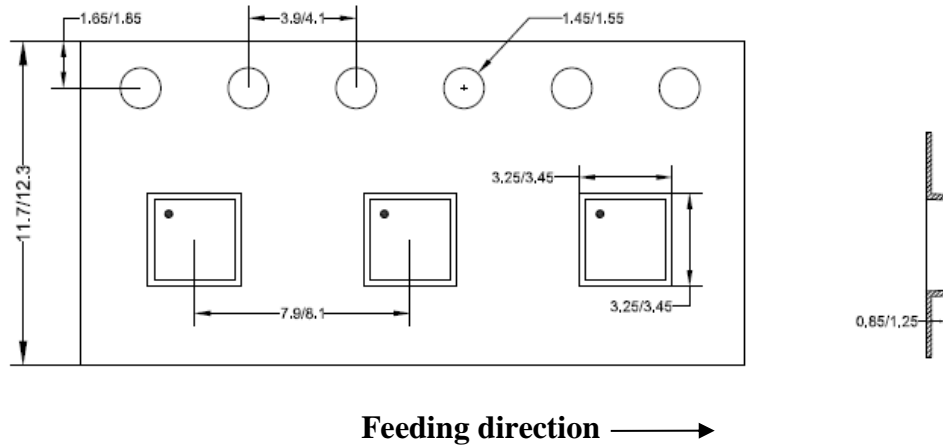

### 2. Carrier Tape & Reel specification for packages

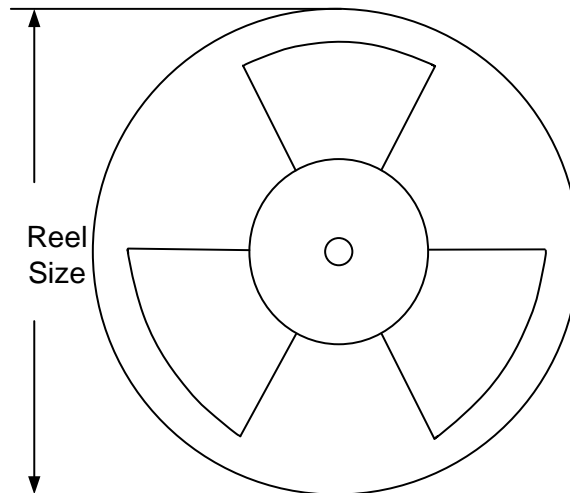

| Package types | Tape width (mm) | Pocket pitch(mm) | Reel size (Inch) | Trailer length(mm) | Leader length (mm) | Qty per reel |
|---------------|-----------------|------------------|------------------|--------------------|--------------------|--------------|
| DFN3×3        | 12              | 8                | 13"              | 400                | 400                | 5000         |

### 3. Others: NA



## IMPORTANT NOTICE

- 1. Right to make changes.** Silergy and its subsidiaries (hereafter Silergy) reserve the right to change any information published in this document, including but not limited to circuitry, specification and/or product design, manufacturing or descriptions, at any time and without notice. This document supersedes and replaces all information supplied prior to the publication hereof. Buyers should obtain the latest relevant information before placing orders and should verify that such information is current and complete. All semiconductor products are sold subject to Silergy's standard terms and conditions of sale.
- 2. Applications.** Application examples that are described herein for any of these products are for illustrative purposes only. Silergy makes no representation or warranty that such applications will be suitable for the specified use without further testing or modification. Buyers are responsible for the design and operation of their applications and products using Silergy products. Silergy or its subsidiaries assume no liability for any application assistance or designs of customer products. It is customer's sole responsibility to determine whether the Silergy product is suitable and fit for the customer's applications and products planned. To minimize the risks associated with customer's products and applications, customer should provide adequate design and operating safeguards. Customer represents and agrees that it has all the necessary expertise to create and implement safeguards which anticipate dangerous consequences of failures, monitor failures and their consequences, lessen the likelihood of failures that might cause harm and take appropriate remedial actions. Silergy assumes no liability related to any default, damage, costs or problem in the customer's applications or products, or the application or use by customer's third-party buyers. Customer will fully indemnify Silergy, its subsidiaries, and their representatives against any damages arising out of the use of any Silergy components in safety-critical applications. It is also buyers' sole responsibility to warrant and guarantee that any intellectual property rights of a third party are not infringed upon when integrating Silergy products into any application. Silergy assumes no responsibility for any said applications or for any use of any circuitry other than circuitry entirely embodied in a Silergy product.
- 3. Limited warranty and liability.** Information furnished by Silergy in this document is believed to be accurate and reliable. However, Silergy makes no representation or warranty, expressed or implied, as to the accuracy or completeness of such information and shall have no liability for the consequences of use of such information. In no event shall Silergy be liable for any indirect, incidental, punitive, special or consequential damages, including but not limited to lost profits, lost savings, business interruption, costs related to the removal or replacement of any products or rework charges, whether or not such damages are based on tort or negligence, warranty, breach of contract or any other legal theory. Notwithstanding any damages that customer might incur for any reason whatsoever, Silergy' aggregate and cumulative liability towards customer for the products described herein shall be limited in accordance with the Standard Terms and Conditions of Sale of Silergy.
- 4. Suitability for use.** Customer acknowledges and agrees that it is solely responsible for compliance with all legal, regulatory and safety-related requirements concerning its products, and any use of Silergy components in its applications, notwithstanding any applications-related information or support that may be provided by Silergy. Silergy products are not designed, authorized or warranted to be suitable for use in life support, life-critical or safety-critical systems or equipment, nor in applications where failure or malfunction of an Silergy product can reasonably be expected to result in personal injury, death or severe property or environmental damage. Silergy assumes no liability for inclusion and/or use of Silergy products in such equipment or applications and therefore such inclusion and/or use is at the customer's own risk.
- 5. Terms and conditions of commercial sale.** Silergy products are sold subject to the standard terms and conditions of commercial sale, as published at <http://www.silergy.com/stdterms>, unless otherwise agreed in a valid written individual agreement specifically agreed to in writing by an authorized officer of Silergy. In case an individual agreement is concluded only the terms and conditions of the respective agreement shall apply. Silergy hereby expressly objects to and denies the application of any customer's general terms and conditions with regard to the purchase of Silergy products by the customer.
- 6. No offer to sell or license.** Nothing in this document may be interpreted or construed as an offer to sell products that is open for acceptance or the grant, conveyance or implication of any license under any copyrights, patents or other industrial or intellectual property rights. Silergy makes no representation or warranty that any license, either express or implied, is granted under any patent right, copyright, mask work right, or other intellectual property right. Information published by Silergy regarding third-party products or services does not constitute a license to use such products or services or a warranty or endorsement thereof. Use of such information may require a license from a third party under the patents or other intellectual property of the third party, or a license from Silergy under the patents or other intellectual property of Silergy.

For more information, please visit: [www.silergy.com](http://www.silergy.com)

© 2020 Silergy Corp.

All Rights Reserved.