

General Description

SY59516 is the high side LLC controller integrated with a 500V MOSFET, it is used in charge pump PFC application. High PF is achieved by inherent PFC function and low LED current ripple is achieved by LLC topology. Single stage structure and primary side regulation save BOM cost a lot. Meanwhile, LLC topology improves efficiency and EMI.

It should work with SY59515, which is the low side LLC controller integrated with a 500V MOSFET.

Ordering Information

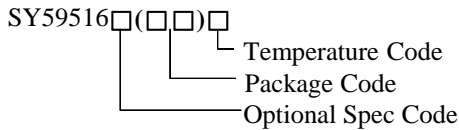

Ordering Number	Package type	Note
SY59516FAC	SO8	----

Features

- Integrated 500V MOSFET
- Charge Pump PFC LLC Topology with Low BOM Cost
- PF>0.95, THD<20%
- Primary Side I_{LED} Regulation and Less than 2% I_{LED} Ripple
- Over Current Protection (OCP), Over Temperature Protection (OTP), Thermal Fold Back (TFB), Adaptive Prevent Capacitive Mode Function
- Zero Voltage Overshoot on Resonant Capacitor at Startup
- Compact Package: SO8

Applications

- LED Lighting

Recommended operating output power @ V _{out} =42V	
Products	198~264Vac
SY59516	42W

Typical Applications

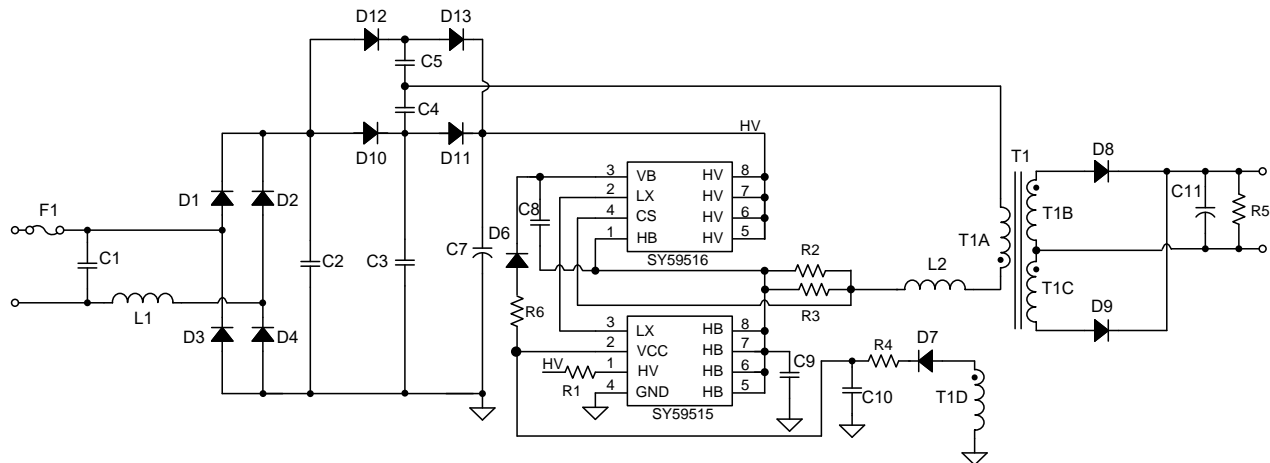

Figure.1a Typical Application

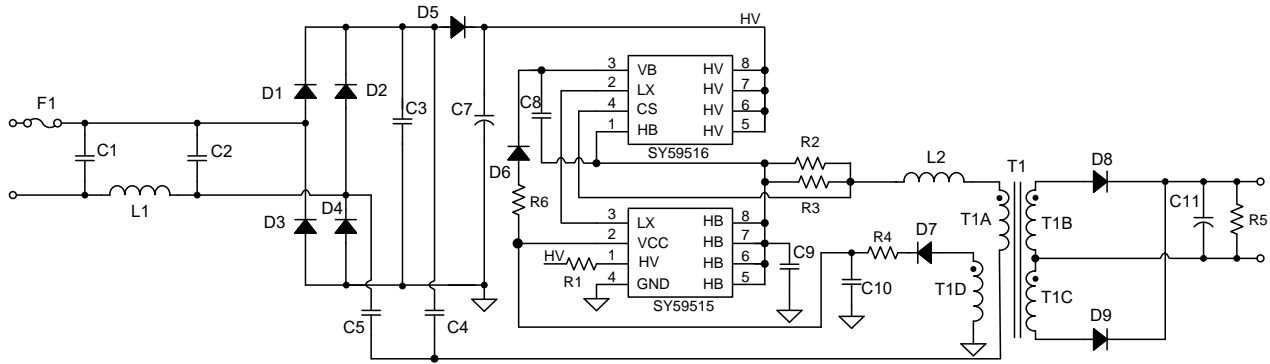

Figure.1b Typical Application

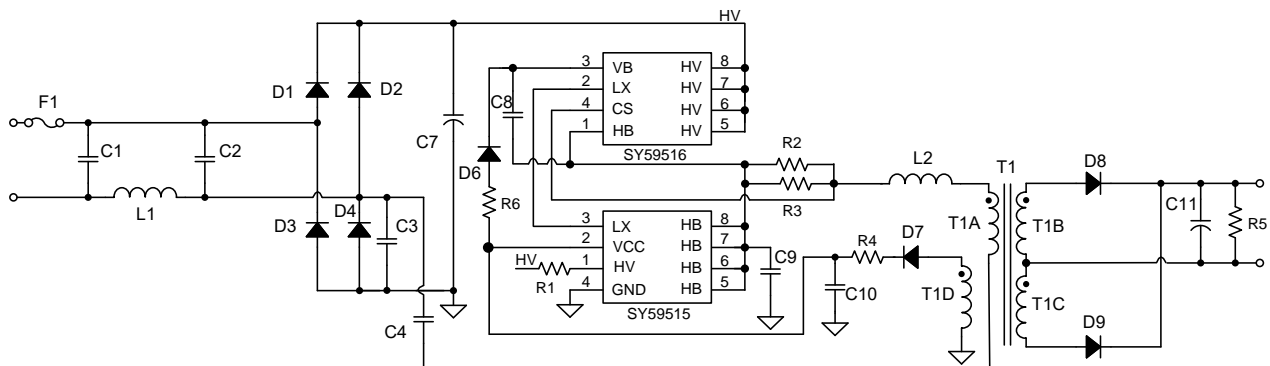

Figure.1c Typical Application

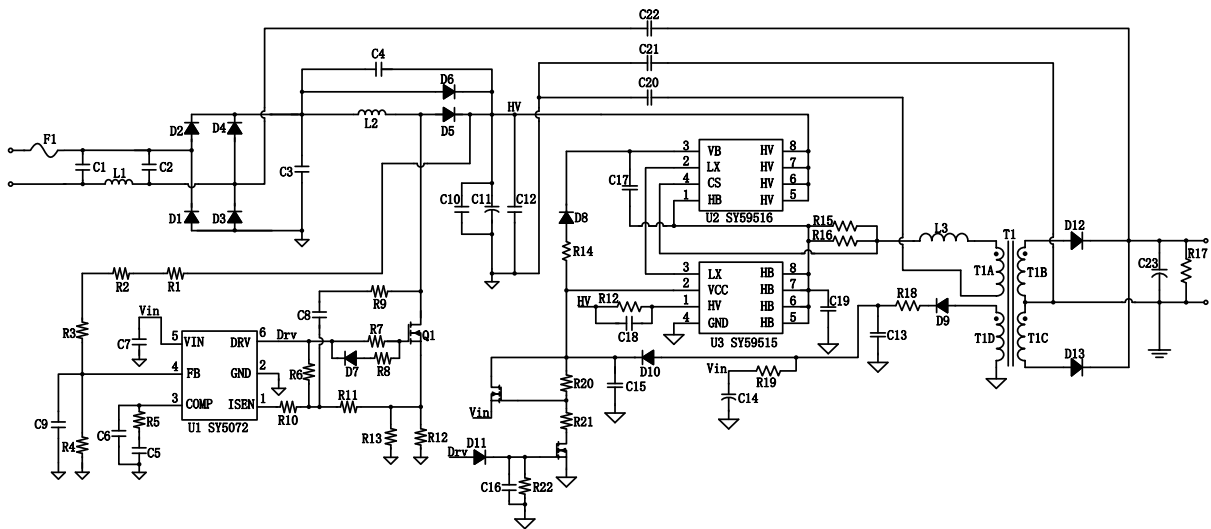
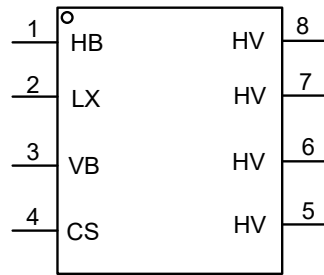

Fig.1d LLC LED Driver with Front End PFC

Pinout (top view)



(SO8)

Top Mark: CUF xyz (device code: CUF, x=year code, y=week code, z=lot number code)

Pin Name	Pin number	Pin Description
HB	1	High-side floating supply reference ground. Source of high side internal 500V MOSFET.
LX	2	Low side driver control pin. This pin sends the control signal to SY59515 through pulling up LX to VB or pulling down LX to HB
VB	3	High-Side Floating Supply.
CS	4	Primary current sense pin. This pin receives the primary resonant current by sample resistors and realizes OCP function. This pin also provides high side and low side MOSFET switching control through internal loop and adaptive prevent capacitive mode function.
HV	5-8	Drain of internal 500V MOSFET.

Block Diagram

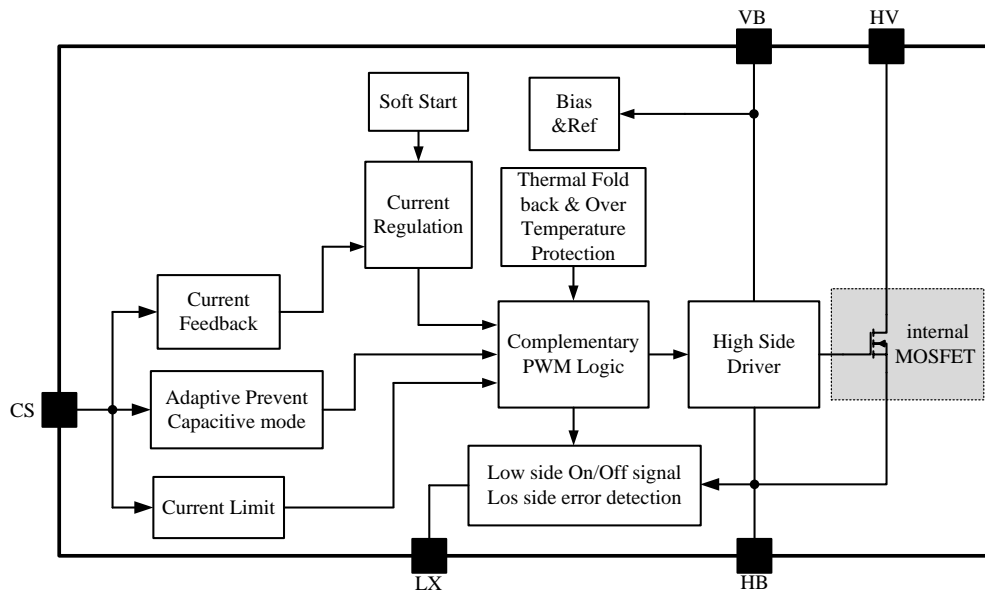

Figure.3 Block Diagram

Absolute Maximum Ratings (Note 1)

HV	-----	-0.3V ~ 500V
LX	-----	-0.3V ~ 36V
VB	-----	-0.3 ~ 36V
CS	-----	-0.6V ~ 0.6V
Power Dissipation, @ TA = 25°C SO8	-----	1.1W
Package Thermal Resistance (Note 2)		
SO8, θ_{JA}	-----	88°C/W
SO8, θ_{JC}	-----	45°C/W
Maximum Junction Temperature	-----	150°C
Lead Temperature (Soldering, 10 sec.)	-----	260°C
Storage Temperature Range	-----	-65°C to 150°C

Recommended Operating Conditions

Junction Temperature Range	-----	-40°C to 150°C
Ambient Temperature Range	-----	-40°C to 150°C

Electrical Characteristics

(V_{IN} = 15V, T_A = 25°C unless otherwise specified)

High Side Controller						
Parameter	Symbol	Test Conditions	Min	Typ	Max	Unit
Power Supply Section						
VB Turn-on Threshold	V _{VB_ON}		20.5	23	25.5	V
VB Turn-off Threshold	V _{VB_OFF}		8.7	9.7	10.7	V
Quiescent current	I _Q	before VB_ON	170	230	290	μA
CS Pin Section						
Current Reference Voltage	V _{REF}		147.5	152	156.5	mV
MOSFET Section						
MOSFET R _{dson}	R _{dson}		0.75	1	1.25	Ω
Breakdown Voltage	V _{BV}	V _{GS} =0, I _{DS} =250μA	500	540		V
Frequency Limit						
Maximum Switching Frequency	F _{MAX}		200	230	260	kHz
Minimum Switching Frequency	F _{MIN}		25	29	33	kHz
Minimum On Time	T _{MIN_ON}		450	575	700	ns
Thermal Section						
Thermal Fold Back Temperature	T _{FB}		139	149	159	°C
Thermal Shut Down Temperature	T _{SD}			160		°C

Note 1: Stresses beyond the “Absolute Maximum Ratings” may cause permanent damage to the device. These are stress ratings only. Functional operation of the device at these or any other conditions beyond those indicated in the operational sections of the specification is not implied. Exposure to absolute maximum rating conditions for extended periods may affect device reliability.

Note 2: θ_{JA} is measured in the natural convection at T_A = 25°C on a low effective single layer thermal conductivity test board of JEDEC 51-3 thermal measurement standard. Test condition: Device mounted on 2” x 2” FR-4 substrate PCB, 2oz copper, with minimum recommended pad on top layer and thermal vias to bottom layer ground plane.

Operation

SY59516 is the high side LLC controller integrated with a 500V MOSFET, it is used in charge pump PFC application, which is targeting at LED lighting applications. High PF is achieved by inherent PFC function and low LED current ripple is achieved by LLC topology. Single stage structure and primary side regulation save BOM cost a lot.

SY59516 contains reliable turn on and turn off logic, which can avoid LLC half bridge shoot through and support high switching frequency more than 200kHz. SY59516 also adopts special design to achieve zero voltage overshoot on resonant capacitor at startup. It also uses slope detection function to make sure the valley turn on of MOSFET to achieve higher efficiency.

LLC topology improves efficiency and EMI, furthermore, one external NP0 capacitor can be put between midpoint between LLC half bridge and GND point (or BUS point) to further improve system performance.

SY59516 provides reliable protections including over current protection (OCP), over temperature protection (OTP), thermal fold back (TFB) and so on.

SY59516 is available with SO8 package, and should work with SY59515, which is the low side LLC controller integrated with a 500V MOSFET.

Applications Information

Start up

After AC supply or DC BUS is powered on, capacitor C_{VCC} across VCC and GND pin is charged by internal current source. This current source comes from HV pin, which is connected to V_{BUS} through one external resistor R_{HV_EXT} .

The whole start up process can be divided into 4 sections shown in Fig.3, HO and LO are internal gate of SY59516 and SY59515, respectively. t_{STC1} is the C_{VCC} charging up section. t_{STD} is midpoint HB voltage and HV voltage detecting section, during this time, C_{VCC} will charge back and forth between V_{VCC_ON} and V_{VCC_OFF} , until HB voltage is below 6V and HV voltage is lower than HV OVP. SY59515 provides a constant internal current to pull down HB voltage through LX pin, so when MOSFET of SY59515 is turned on, there won't be large resonant current flowing through resonant capacitor. After the above two conditions are met, SY59515 will exit t_{STD} stage and enter into t_{STC2} stage.

t_{STC2} is the C_{VCC} together with C_{VB} charging up section, once V_{VB} reaches V_{VB_ON} , internal MOSFET of SY59515 is turned off, switching control starts to work and HV pin stops to provide charge current. t_{STO} is the output voltage building up section, V_{VCC} and V_{VB} will be pulled down by internal consumption current until the auxiliary winding of LLC transformer can supply enough energy to maintain V_{VCC} above V_{VCC_OFF} .

Design of HV pin resistor R_{HV_EXT} , C_{VCC} and C_{VB} is not strict, below are some suggestions:

- Use R_{HV_EXT} smaller than 200kohms, resistance of R_{HV_EXT} will influence E-cap over voltage protection (HV OVP).
- Use C_{VCC} larger than 470nF, use C_{VB} larger than 100nF, there no need to use very large C_{VCC} or C_{VB} capacitor, suggest using 2uF C_{VCC} and 1uF C_{VB} .
- If C_{VCC} and C_{VB} are not big enough to build up output voltage at one time, increase C_{VCC} and C_{VB} , or check whether the output E-cap is too large.

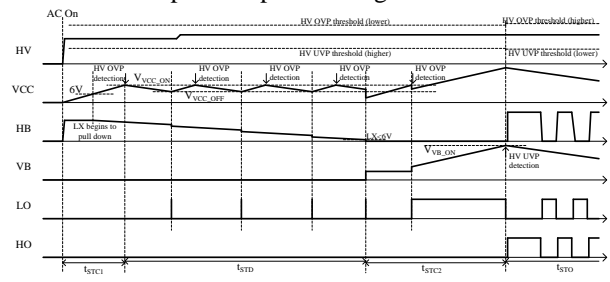

Fig.3 Start up Process of SY59516 and SY59515

After V_{VB_ON} and high side MOSFET is turned on, soft start up function works, it prevents resonant current from being too high at start up. Switching frequency is fixed at maximum switching frequency f_{SW_MAX} during the first few resonant periods.

Primary side LED current regulation (PSR)

The PSR principle is as follows: LED current is estimated by sensing primary side resonant current, sampling resistor is put between HB and inductor or transformer, HB is the source of internal MOSFET of SY59516 and the drain of internal MOSFET of SY59515, so both current flowing into HB and current flowing out of HB can be detected.

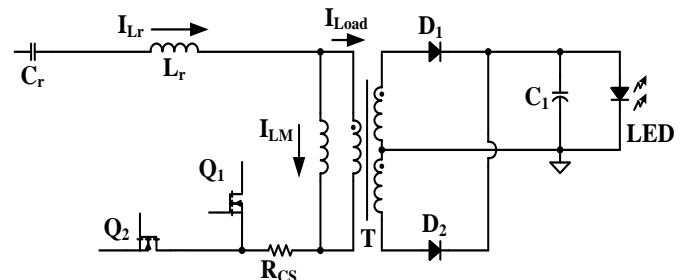

Fig.4 PSR principle of SY59516

The output current program is shown as below:

$$I_{LED} \approx \frac{V_{REF} \times N_{PS}}{R_{CS}}$$

So I_{LED} can be programmed by CS pin resistor.

Shut down

After AC supply or DC BUS is powered off, LLC still works for a while to consume the energy stored in input E-cap. During this time, auxiliary winding can still provide stable VCC voltage so SY59515 and SY59516 can continue with the internal working logic. Once HV pin voltage reaches E-cap under voltage protection (HV UVP), SY59515 will keep internal MOSFET off and SY59516 will turn off its internal MOSFET soon. Once high side and low side MOSFET are turned off, C_{VCC} and C_{VB} will discharge, discharge current of C_{VCC} is quiescent current of SY59515 and discharge current of C_{VB} is constant 6mA. Usually, V_{VB} reaches V_{VB_OFF} earlier than V_{VCC} reaches V_{VCC_OFF} . When V_{VB} reaches V_{VB_OFF} , 6mA discharge current will be removed. When V_{VCC} reaches V_{VCC_OFF} , SY59515 will restart and HV pin starts to provide charge current.

Over current protection (OCP), Over temperature protection (OTP), Thermal fold back (TFB)

OCP: CS voltage reflects resonant current, when $|V_{RCS}|$ reaches 500mV, SY59516 will force change the LX state and force switch the high side and low side MOSFET. Under normal parameter design, it's not easy to trigger OCP. OCP is also not common in other protections, such as OTP, OLP, and SLP. Under special conditions, such as resonant inductor fault or transformer fault, OCP can protect the system from overheating. OCP won't restart the system, it only increases the switching frequency, because the MOSFET is switched earlier.

TFB: When temperature is too high, V_{REF} will begin to drop, the specific curve is shown in Fig.5. When SY59516 reaches 149°C, V_{REF} begins to drop, as the temperature rises, V_{REF} goes down at a constant slope. When SY59516 reaches 155°C, V_{REF} drops to 50% of the rated value and if the temperature keeps rising, V_{REF} keeps constant and stops to drop.

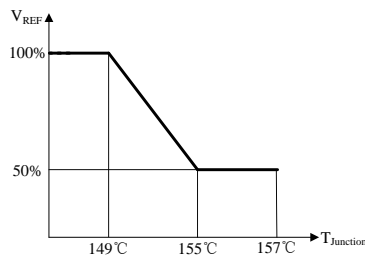

Fig.5 Thermal Fold Back Curve of SY59516

OTP: When SY59516 reaches 157°C, SY59516 will enter fault state, it will turn off high side MOSFET and

pull up LX, so low side MOSFET is turned off, too. At the same time, SY59516 begins to discharge by 6mA until V_{VB} reaches V_{VB_OFF} . Later when V_{VCC} reaches V_{VCC_OFF} , SY59515 begins to restart. After restart, SY59516 will recognize OTP signal after V_{VB_ON} , so even if temperature is always too high, MOSFET won't switching and system's heat is very low, there is no risk of overheating.

Magnetic Element Design

According to the design table, calculate the resonant inductor, resonant capacitor and boost capacitor. Left part of design table is one standard design with good performance, this topology has good normalized property, which means the resonant parameters is related to output current I_O , resonant frequency f_r and maximum output voltage V_{O_MAX} .

Inductor

System works in LC resonant condition, the peak value and RMS value of resonant current can be calculated:

$$I_{r_peak} = 2 \times I_O / N_{ps}$$

$$I_{RMS} = \frac{I_{r_peak}}{\sqrt{3}}$$

Usually select B_{max_ind} between 0.2 and 0.3, so turn number of inductor can be calculated:

$$n_{ind} = \frac{I_{r_peak} \times L_r}{A_{e_ind} \times B_{max_ind}}$$

It's recommended to use litz wire for lower temperature rise. Current density j_{ind} is selected at 8A/mm², so the number of 0.1mm enameled wire n_{litz} can be calculated:

$$n_{litz} = \frac{4 \times I_{RMS}}{\pi \times j_{ind} \times 0.1^2}$$

Transformer

RMS value of primary winding current is the same as inductor, so the wire diameters of primary and secondary winding are easy to get. Usually select B_{max_trans} as 0.3, and the turn number of primary winding can be calculated:

$$n_{p_trans} = \frac{V_{O_MAX} \times n_{ps}}{4 \times f_r \times B_{max_trans} \times A_{e_trans}}$$

$$n_{s_trans} = \frac{n_{s_trans}}{n_{ps}}$$

The auxiliary winding should satisfy the following conditions:

$$V_{O_OLP} + V_D = \frac{N_s}{N_{AUX}} \times (V_{VCC_OVP} + V_D)$$

$$(V_{O_MIN} + V_D) \times \frac{N_{AUX}}{N_s} - V_D > 13V$$

No air gap is required for transformer cores, large inductance of primary winding is needed, it's suggested that the ratio of inductance of primary winding and resonant inductor be larger than 3. If the ratio is small, it

needs to change the bobbin and core size of inductor or transformer.

Magnetic integrated design

It's recommended to use magnetic integrated design for better efficiency and power density. In this design, leakage inductance of transformer primary winding is used as resonant inductor, so the key of magnetic integrated design is the control of leakage inductance. Fig.6 shows the structure of magnetic integrated transformer, primary and secondary windings are placed at left side and right side, respectively, between them is a big gap for larger leakage inductance. Leakage inductance mainly depends on the turn number of primary winding, bobbin size and the big gap in the middle. Red line represents the leakage inductance of primary winding, which is equivalent to the role of resonant inductor, and the green line represents the transformer excitation loop.

In magnetic integrated design, usually it's no need to consider the inductance ratio between primary winding and resonant inductor, because the bobbin size of transformer becomes larger than discrete design, the excitation inductance is much larger.

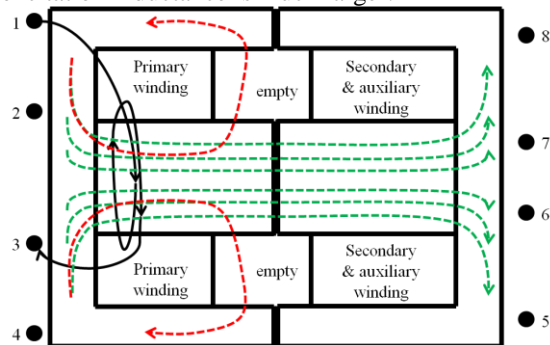
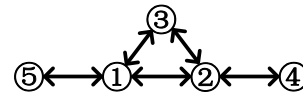

Fig.6 Structure of Magnetic Integrated Transformer

Layout

- (a) Because of the charge pump structure, it's not necessary to put the input E-cap close to bridge rectifier. Make sure the loop composed of input E-cap, HV of SY59516, HB of SY59516, HB of SY59515 and GND of SY59515 to be as small as possible.
- (b) The circuit loop of CS sampling should be kept small.
- (c) The C_{VB} charge loop should be kept small, C_{VB} should be put near SY59516.
- (d) The C_{VCC} and N_{AUX} charging loop should be kept small, C_{VCC} should be put near SY59515.
- (e) Not recommend to put high voltage track under low voltage components, such as HV and LX.
- (f) Recommend to use a high voltage MLCC in parallel with input E-cap, recommend to connect the core of inductor to low frequency input line after filter.
- (g) The connection of ground is recommended as:



- Ground ①: ground of input E-cap
- Ground ②: ground of SY59515 and C_{VCC}
- Ground ③: ground of external high voltage NP0 MLCC
- Ground ④: ground of auxiliary winding
- Ground ⑤: ground of bridge rectifier and C_{boost}

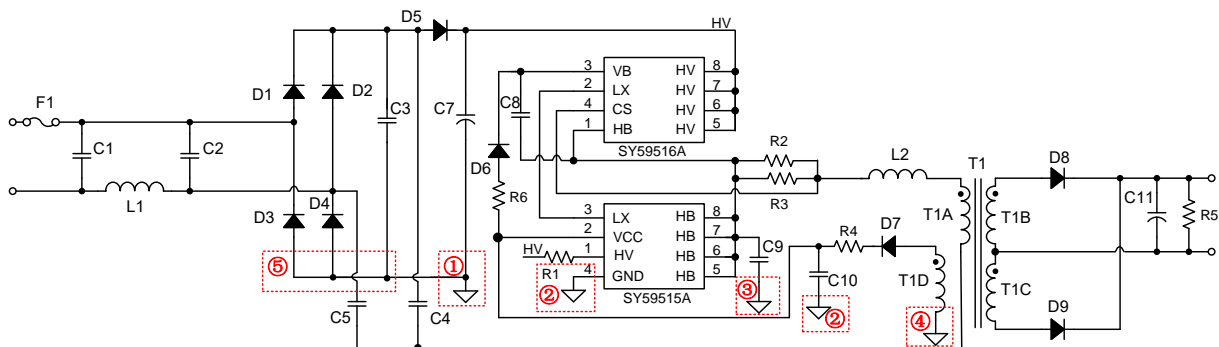

Fig.7 Ground Connection Recommended

Design Example

Table 1 and table 2 show the key parameters of standard design in design table and parameters defined by the customer, respectively. The relationship between them is also provided.

Table 1 Key Parameters of Standard Design

System Conditions		
Maximum Output Voltage	$V_{O_MAX_S}$	42V
Output Current	I_{O_S}	1A
Output Diode Drop	V_{DF_S}	1.3V
Main Resonant Frequency	f_{r_S}	52.5kHz
Key Parameters		
Turns Ratio	N_{PS_S}	1.75
Sampling Resistor	R_{CS_S}	0.26Ω
Resonant Inductor	L_{r_S}	700uH
Main Resonant Capacitor	C_{r_S}	27nF
Minor Resonant Capacitor	C_{r2_S}	3.3nF
Boost Capacitor	C_{boost_S}	15nF
Input E-cap	C_{in_S}	15uF

Table 2 Parameters Defined by Customer

System Conditions		
Maximum Output Voltage	$V_{O_MAX_C}$	40V
Output Current	I_{O_C}	0.8A
Output Diode Drop	V_{DF_C}	1.3V
Main Resonant Frequency	f_{r_C}	70kHz
Key Parameters		
Turns Ratio	N_{PS_C}	1.83
Sampling Resistor	R_{CS_C}	0.34Ω
Resonant Inductor	L_{r_C}	689uH
Main Resonant Capacitor	C_{r_C}	15.4nF
Minor Resonant Capacitor	C_{r2_C}	1.9nF
Boost Capacitor	C_{boost_C}	8.6nF
Input E-cap	C_{in_C}	11uF

$$N_{PS_C} = N_{PS_S} \times \frac{V_{O_MAX_S} + V_{DF_S}}{V_{O_MAX_C} + V_{DF_C}}$$

$$R_{CS_C} = 0.15 \times \frac{N_{PS_C}}{I_{O_C}}$$

$$L_{r_C} = L_{r_S} \times \frac{V_{O_MAX_S} \times I_{O_S} \times f_{r_S}}{V_{O_MAX_C} \times I_{O_C} \times f_{r_C}}$$

$$C_{r_C} = C_{r_S} \times \frac{V_{O_MAX_C} \times I_{O_C} \times f_{r_S}}{V_{O_MAX_S} \times I_{O_S} \times f_{r_C}}$$

$$C_{r2_C} = C_{r2_S} \times \frac{V_{O_MAX_C} \times I_{O_C} \times f_{r_S}}{V_{O_MAX_S} \times I_{O_S} \times f_{r_C}}$$

$$C_{boost_C} = C_{boost_S} \times \frac{V_{O_MAX_C} \times I_{O_C} \times f_{r_S}}{V_{O_MAX_S} \times I_{O_S} \times f_{r_C}}$$

$$C_{in_C} = C_{in_S} \times \frac{V_{O_MAX_C} \times I_{O_C}}{V_{O_MAX_S} \times I_{O_S}}$$

$V_{O_MAX_C}$, I_{O_C} , V_{DF_C} and f_{r_C} are defined by customer, and other key parameters will be calculated according to the above normalization formula.

SO8 Package outline & PCB layout design

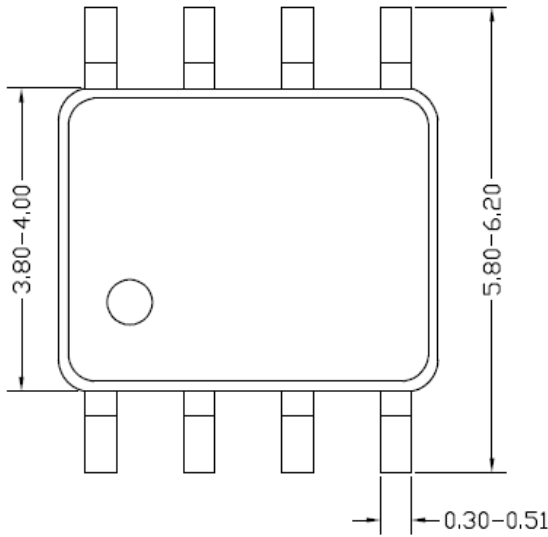

Top view

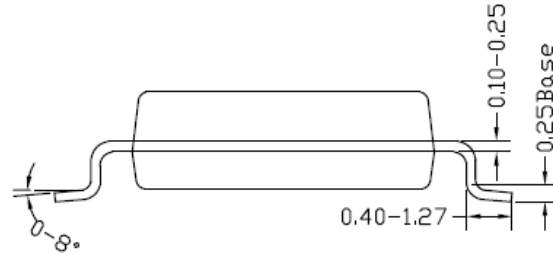

Side view

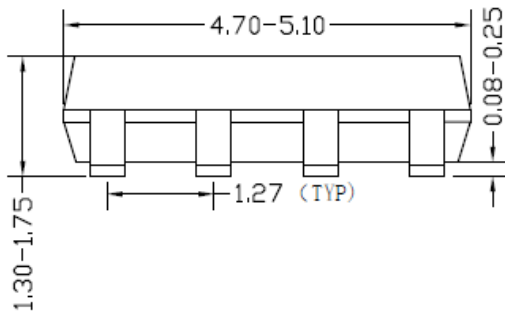

Front view

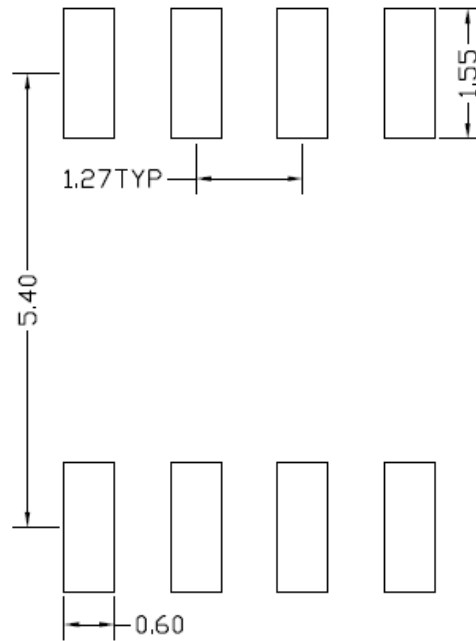

**Recommended Pad Layout
(Reference only)**

Notes: All dimension in millimeter and exclude mold flash & metal burr.



Revision History

The revision history provided is for informational purpose only and is believed to be accurate, however, not warranted. Please make sure that you have the latest revision.

Date	Revision	Change
December 28,2021	Revision 0.9	Initial Release

IMPORTANT NOTICE

1. **Right to make changes.** Silergy and its subsidiaries (hereafter Silergy) reserve the right to change any information published in this document, including but not limited to circuitry, specification and/or product design, manufacturing or descriptions, at any time and without notice. This document supersedes and replaces all information supplied prior to the publication hereof. Buyers should obtain the latest relevant information before placing orders and should verify that such information is current and complete. All semiconductor products are sold subject to Silergy's standard terms and conditions of sale.
2. **Applications.** Application examples that are described herein for any of these products are for illustrative purposes only. Silergy makes no representation or warranty that such applications will be suitable for the specified use without further testing or modification. Buyers are responsible for the design and operation of their applications and products using Silergy products. Silergy or its subsidiaries assume no liability for any application assistance or designs of customer products. It is customer's sole responsibility to determine whether the Silergy product is suitable and fit for the customer's applications and products planned. To minimize the risks associated with customer's products and applications, customer should provide adequate design and operating safeguards. Customer represents and agrees that it has all the necessary expertise to create and implement safeguards which anticipate dangerous consequences of failures, monitor failures and their consequences, lessen the likelihood of failures that might cause harm and take appropriate remedial actions. Silergy assumes no liability related to any default, damage, costs or problem in the customer's applications or products, or the application or use by customer's third-party buyers. Customer will fully indemnify Silergy, its subsidiaries, and their representatives against any damages arising out of the use of any Silergy components in safety-critical applications. It is also buyers' sole responsibility to warrant and guarantee that any intellectual property rights of a third party are not infringed upon when integrating Silergy products into any application. Silergy assumes no responsibility for any said applications or for any use of any circuitry other than circuitry entirely embodied in a Silergy product.
3. **Limited warranty and liability.** Information furnished by Silergy in this document is believed to be accurate and reliable. However, Silergy makes no representation or warranty, expressed or implied, as to the accuracy or completeness of such information and shall have no liability for the consequences of use of such information. In no event shall Silergy be liable for any indirect, incidental, punitive, special or consequential damages, including but not limited to lost profits, lost savings, business interruption, costs related to the removal or replacement of any products or rework charges, whether or not such damages are based on tort or negligence, warranty, breach of contract or any other legal theory. Notwithstanding any damages that customer might incur for any reason whatsoever, Silergy' aggregate and cumulative liability towards customer for the products described herein shall be limited in accordance with the Standard Terms and Conditions of Sale of Silergy.
4. **Suitability for use.** Customer acknowledges and agrees that it is solely responsible for compliance with all legal, regulatory and safety-related requirements concerning its products, and any use of Silergy components in its applications, notwithstanding any applications-related information or support that may be provided by Silergy. Silergy products are not designed, authorized or warranted to be suitable for use in life support, life-critical or safety-critical systems or equipment, nor in applications where failure or malfunction of an Silergy product can reasonably be expected to result in personal injury, death or severe property or environmental damage. Silergy assumes no liability for inclusion and/or use of Silergy products in such equipment or applications and therefore such inclusion and/or use is at the customer's own risk.
5. **Terms and conditions of commercial sale.** Silergy products are sold subject to the standard terms and conditions of commercial sale, as published at <http://www.silergy.com/stdterms>, unless otherwise agreed in a valid written individual agreement specifically agreed to in writing by an authorized officer of Silergy. In case an individual agreement is concluded only the terms and conditions of the respective agreement shall apply. Silergy hereby expressly objects to and denies the application of any customer's general terms and conditions with regard to the purchase of Silergy products by the customer.
6. **No offer to sell or license.** Nothing in this document may be interpreted or construed as an offer to sell products that is open for acceptance or the grant, conveyance or implication of any license under any copyrights, patents or other industrial or intellectual property rights. Silergy makes no representation or warranty that any license, either express or implied, is granted under any patent right, copyright, mask work right, or other intellectual property right. Information published by Silergy regarding third-party products or services does not constitute a license to use such products or services or a warranty or endorsement thereof. Use of such information may require a license from a third party under the patents or other intellectual property of the third party, or a license from Silergy under the patents or other intellectual property of Silergy.

For more information, please visit: www.silergy.com

© 2021 Silergy Corp.

All Rights Reserved.