

2A, High Accuracy, Low Noise LDO Voltage Regulator

General Description

The SY6321B is a low-dropout (LDO) voltage regulator capable of sourcing 2 A with only 200 mV of dropout.

The SY6321B output is adjustable with external resistors from 0.8V to 5.2V. The SY6321B wide input-voltage range supports operation as low as 1.8V and up to 6.5V.

With 2% output voltage accuracy (over line, load and temperature) and soft-start capabilities to reduce inrush current.

The SY6321B adopts a compacted DFN 2.5×2.5-10 footprint.

Features

- 2.0% Accuracy Over Line, Load and Temperature
- Low Dropout: 200 mV (Typ) at 2 A
- Wide Input Voltage Range: 1.8 V to 6.5 V
- Wide Output Voltage Range: 0.8 V to 5.2V
- Fast Transient Response
- Adjustable Start-up In-Rush Control with Selectable Soft-start Charging Current
- Open-Drain Power-Good (PG) Output
- Stable with a 22μF or Larger Ceramic Output Capacitor
- RoHS Compliant and Halogen Free
- 2.5mm × 2.5mm, 10-Pin DFN Package

Applications

- High Speed Analog Circuits: VCO, ADC, DAC, LVDS
- Imaging: CMOS Sensors, Video ASICs
- Test and Measurement
- Instrumentation, Medical, and Audio
- Digital Loads: SerDes, FPGA, DSP

Typical Applications

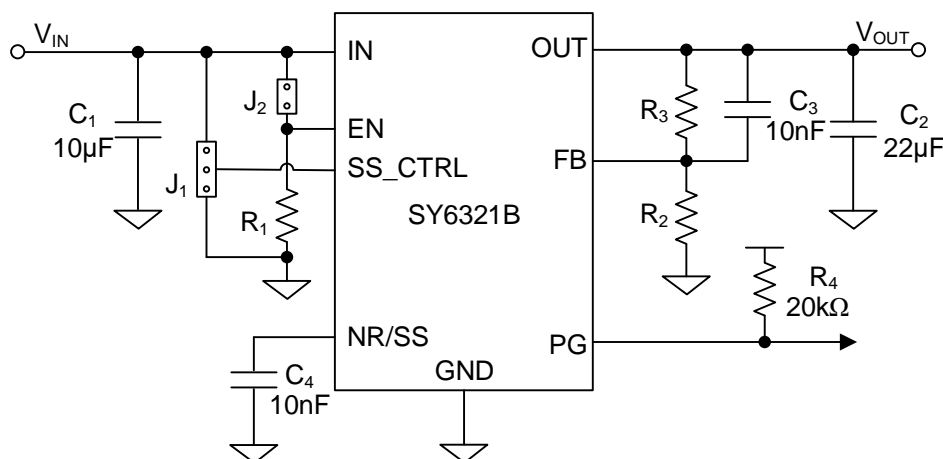

Figure 1. Schematic Diagram

Ordering Information

Ordering Part Number	Package Type	Top Mark
SY6321BSED	DFN2.5×2.5-10 RoHS Compliant and Halogen Free	f6xyz

x = year code, y = week code, z = lot number code

Pinout (top view)

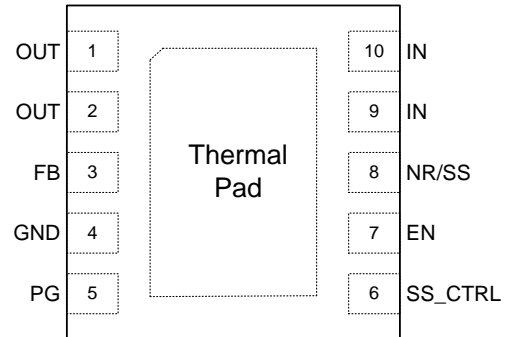

Pin Name	NO.	I/O	Pin Description
OUT	1, 2	O	Regulated output. A 22 μ F or greater capacitor must be connected from this pin to GND for stability.
FB	3	I	Feedback pin. This pin is the input to the control loop error amplifier and is used to set the output voltage of the device.
GND	4	—	Device GND. Connect to the device thermal pad.
PG	5	O	Open-drain power-good indicator pin for the LDO output voltage. A 10k Ω to 100k Ω external pull-up resistor is required. This pin can be left floating or connected to GND if not used.
SS_CTRL	6	I	Soft-start control pin. Connect this pin either to GND or IN to change the NR/SS capacitor charging current. If a C _{NR/SS} capacitor is not used, SS_CTRL must be connected to GND to avoid output overshoot.
EN	7	I	Enable pin. This pin turns the LDO on and off. If $V_{EN} \geq V_{EN(HI)}$, the regulator is enabled. If $V_{EN} \leq V_{EN(LO)}$, the regulator is disabled. The EN pin must be connected to IN if the enable function is not used.
NR/SS	8	—	Noise reduction pin. Connect this pin to an external capacitor to bypass the noise generated by the internal bandgap reference. The capacitor reduces the output noise to very low levels and sets the output ramp rate to limit inrush current.
IN	9, 10	I	Input pin. A 10 μ F or greater input capacitor is required.
Thermal Pad		—	Connect the thermal pad to PCB ground plane.

Block Diagram

Figure2. Block Diagram

Absolute Maximum Ratings

Parameter (Note 1)	Min	Max	Unit
IN, PG	-0.3	7	V
OUT, SS_CTRL, NR/SS, EN, FB	-0.3	IN+0.3	
Lead Temperature (Soldering, 10s)		260	°C
Junction Temperature, Operating	-40	150	
Storage Temperature	-65	150	

Thermal Information

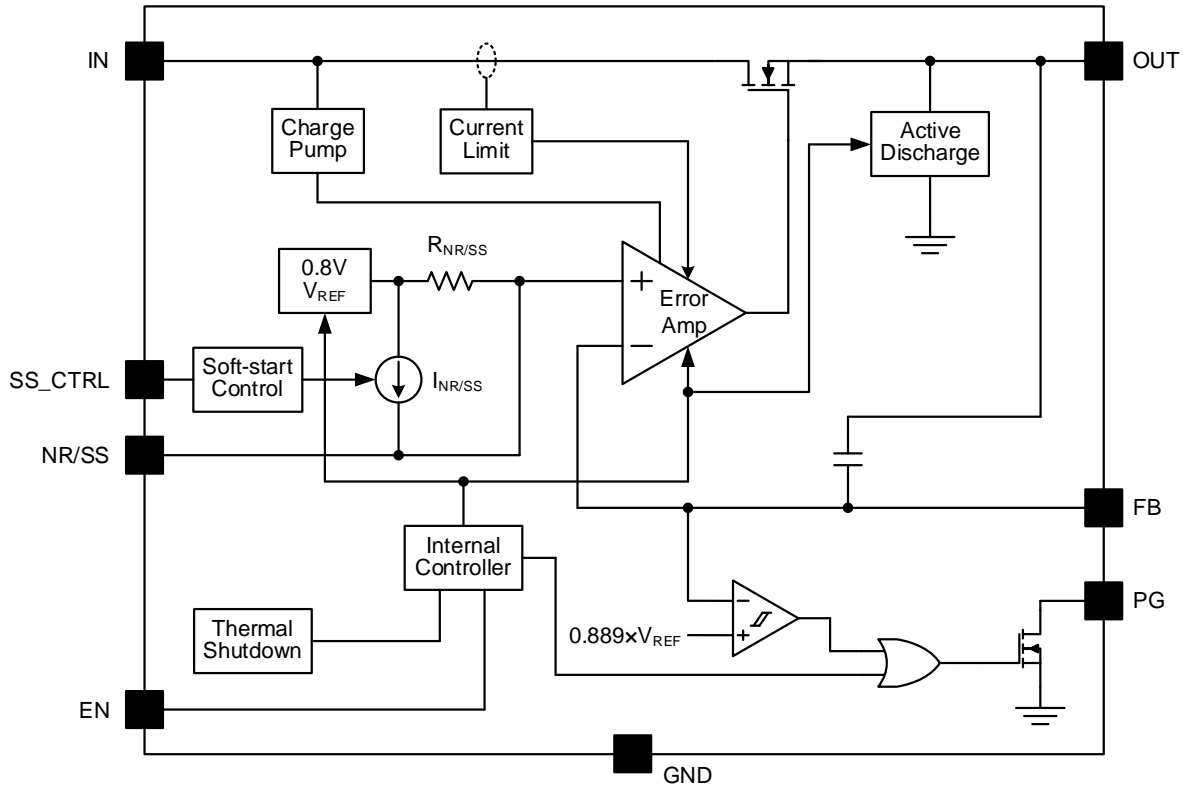
Parameter (Note 2)	Typ	Unit
θ_{JA} Junction-to-Ambient Thermal Resistance	61	°C/W
θ_{JC} Junction-to-Case Thermal Resistance	15	
PD Power Dissipation $T_A = 25^\circ\text{C}$	1.64	W

Recommended Operating Conditions

Parameter (Note 3)	Min	Max	Unit
IN	1.8	6.5	V
OUT	0.8-1%	5.2+1%	
Maximum Output Current		2	A
C _{IN}	10		μF
C _{OUT}	22		
C _{NR/SS}		1	
R _{PG}	10	100	kΩ
Junction Temperature, Operating	-40	125	°C

Note 1: Stresses beyond the “Absolute Maximum Ratings” may cause permanent damage to the device. These are stress ratings only. Functional operation of the device at these or any other conditions beyond those indicated in the operational sections of the specification is not implied. Exposure to absolute maximum rating conditions for extended periods may affect device reliability.

Note 2: θ_{JA} is simulated in the natural convection at $T_A=25^\circ\text{C}$ on a Silergy evaluation board following JEDEC51-2 thermal measurement standard. Exposed Pad of DFN2.5x2.5-10 package is the case position for θ_{JC} measurement.

Note 3: The device is not guaranteed to function outside its operating conditions.

Electrical Characteristics

($V_{IN} = 1.8\text{V}$, $V_{OUT} = 0.8\text{V}$, $I_{OUT} = 50\text{mA}$, $V_{EN} = 1.8\text{V}$, $C_{OUT} = 22\mu\text{F}$, $C_{NR/SS} = 0\text{nF}$, $C_{FF} = 0\text{nF}$, $SS_CTRL=GND$, $R_{PG} = 20\text{k}\Omega$. $T_J = -40^\circ\text{C}\sim 125^\circ\text{C}$, typical values are at $T_J=25^\circ\text{C}$, unless otherwise specified, the values are guaranteed by test, design or statistical correlation)

Parameter	Symbol	Test Conditions	Min	Typ	Max	Unit
Input Voltage Range	V_{IN}		1.8		6.5	V
Reference Voltage	V_{REF}			0.8		V
Output Voltage Range	V_{OUT}		0.8-2.0%		5.2+2.0%	V
Output Voltage Accuracy		$0.8\text{V} \leq V_{OUT} \leq 5\text{V}$, $5\text{mA} \leq I_{OUT} \leq 2\text{A}$, $T_J=25^\circ\text{C}$	-1.0%		1.0%	
		$T_J = -40^\circ\text{C}\sim 125^\circ\text{C}$	-2.0%		2.0%	
Line Regulation	ΔV_{OUT}	$I_{OUT} = 5\text{mA}$, $1.8\text{V} \leq V_{IN} \leq 6.5\text{V}$		0.11		%/V
Load Regulation	ΔV_{OUT}	$V_{IN} = 3.3\text{V}$, $5\text{mA} \leq I_{OUT} \leq 2\text{A}$		0.45		%/A
Dropout Voltage	V_{DO}	$V_{IN} \geq 1.8\text{V}$, $0.8\text{V} \leq V_{OUT} \leq 5.0\text{V}$, $I_O = 2\text{A}$, $V_{FB} = 0.8\text{V} - 3\%$			400	mV
Output Current Limit	I_{LIMIT}	V_{OUT} forced at $0.9 \times V_{OUT(TARGET)}$, $V_{IN} = 3.3\text{V}$	2.1	2.6	4.4	A
GND Pin Current	I_{GND}	$V_{IN} = 6.5\text{V}$, $I_{OUT} = 5\text{mA}$		1	2.5	mA
		$V_{IN} = 1.8\text{V}$, $I_{OUT} = 2\text{A}$			3	
Shutdown GND Pin Current	I_{SDN}	$PGX = (\text{open})$, $V_{IN} = 6.5\text{V}$, $V_{EN} = 0\text{V}$, $T_J=25^\circ\text{C}$		0.1	12	μA
		$PGX = (\text{open})$, $V_{IN} = 6.5\text{V}$, $V_{EN} = 0\text{V}$, $T_J=125^\circ\text{C}$			50	
FB Pin Leakage Current	I_{FB}	$V_{IN} = 6.5\text{V}$, $V_{FB} = 0.8\text{V}$	-100		100	nA
EN High Level	$V_{EN(HI)}$	$V_{IN} = 3.3\text{V}$	1.2		6.5	V
EN Low Level	$V_{EN(LO)}$	$V_{IN} = 3.3\text{V}$	0		0.4	V

Parameter	Symbol	Test Conditions	Min	Typ	Max	Unit
Enable Pin Current	I _{EN}	V _{IN} = 6.5V, 0V ≤ V _{EN} ≤ 6.5V	-0.2		0.2	μA
SS_CTRL Pin Current	I _{SS_CTRL}	V _{IN} = 6.5V, 0 V ≤ V _{SS_CTRL} ≤ 6.5V	-0.2		0.2	μA
PG Pin Threshold	V _{IT(PG)}	For PG transitioning low with falling V _{OUT} , expressed as a percentage of V _{OUT(TARGET)}	84%	89.3%	94.5%	
PG Pin Hysteresis	V _{HYS(PG)}	For PG transitioning high with rising V _{OUT} , expressed as a percentage of V _{OUT(TARGET)}		1%		
PG Pin Low-Level Output Voltage	V _{OL(PG)}	V _{OUT} < V _{IT(PG)} , I _{PG} = -1 mA (current into device)			0.4	V
PG Pin Leakage Current	I _{LKG(PG)}	V _{OUT} > V _{IT(PG)} , V _{PG} = 6.5 V			1	μA
NR/SS Pin Charging Current	I _{NR/SS}	V _{NR/SS} = GND, V _{IN} =3.3V, V _{SS_CTRL} = GND	4.5	8.5	13	μA
		V _{NR/SS} = GND, V _{IN} =3.3V, V _{SS_CTRL} = V _{IN}	85	135	200	
Power Supply Ripple Rejection	PSRR	f = 500 kHz, V _{IN} = 2.0V, V _{OUT} = 1.2V, I _{OUT} = 2A, C _{NR/SS} = 10nF, C _{FF} = 10nF		40		dB
Output Active Discharge Resistance	R _{DIS}	V _{IN} =3.3V, V _{EN} =GND, V _{OUT} =0.1V	100	150	200	Ω
Thermal Shutdown Threshold	T _{SD}	Shutdown, temperature increasing		160		°C
Thermal Shutdown Hysteresis		Reset, temperature decreasing		140		°C

Typical Performance Characteristics

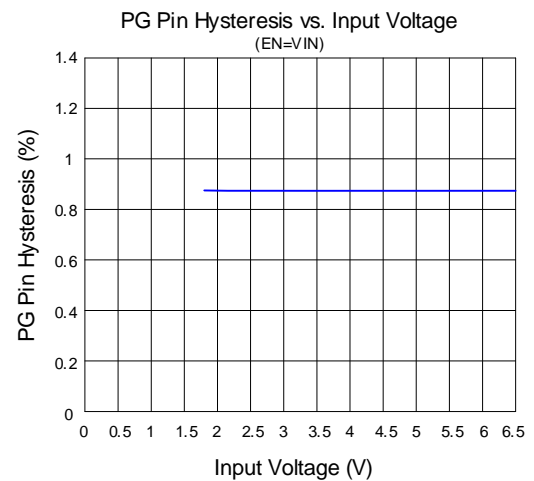
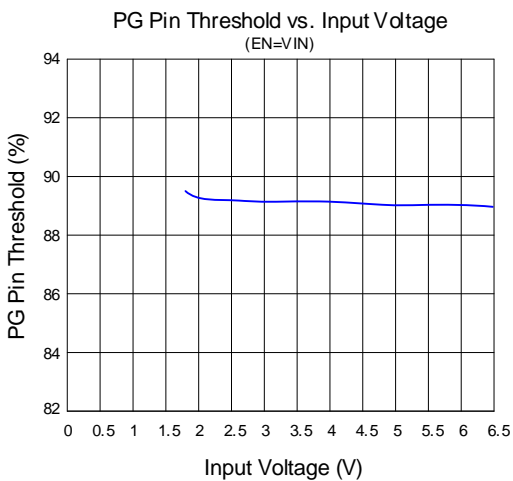
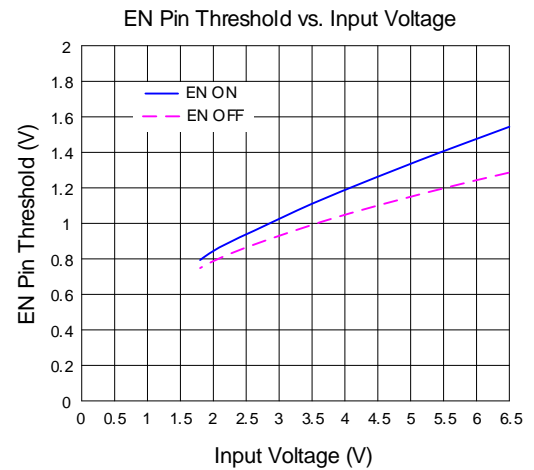
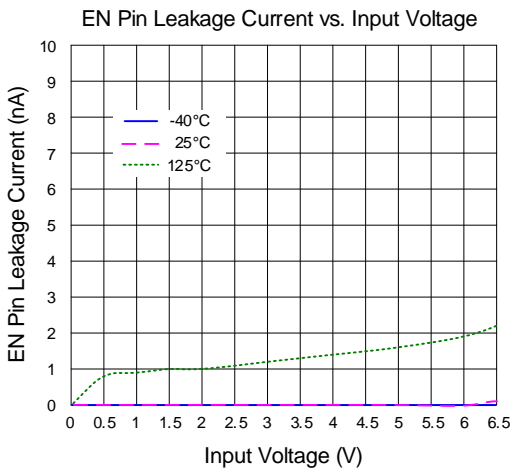
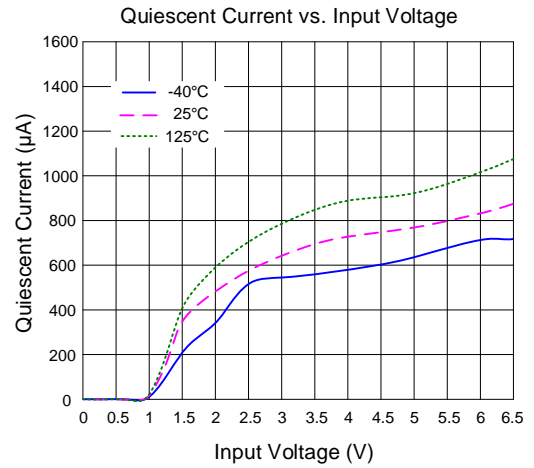
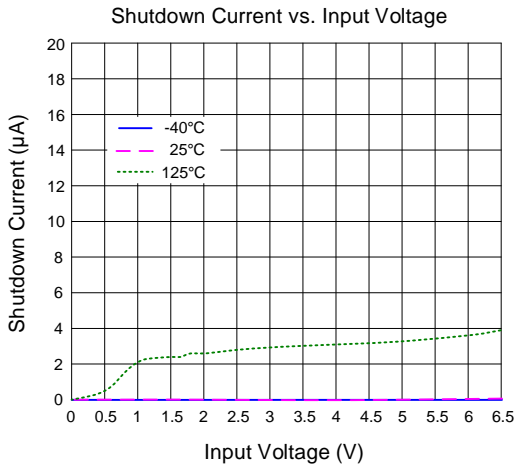

NR/SS Charging Current vs. NR/SS Voltage
(SS_CTRL = GND)

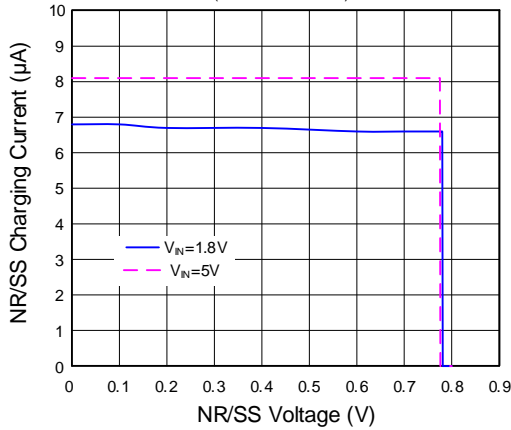

NR/SS Charging Current vs. NR/SS Voltage
(SS_CTRL = VIN)

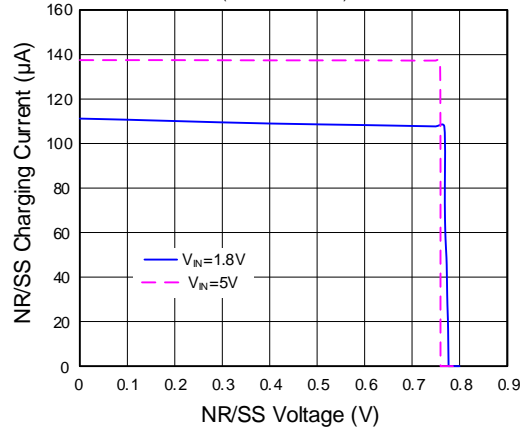

Output Voltage vs. Output Current Limit
(V_IN=5V, EN=5V, V_OUT=3.3V)

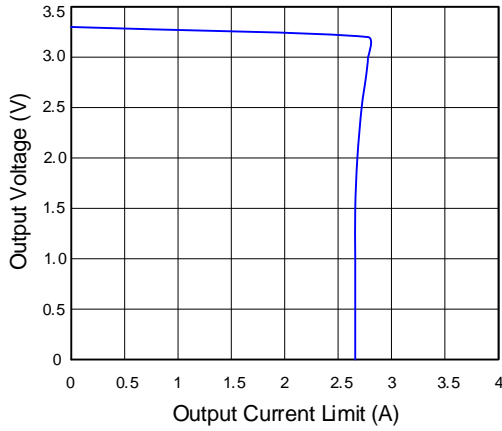

Line Regulation
(I_OUT=5mA)

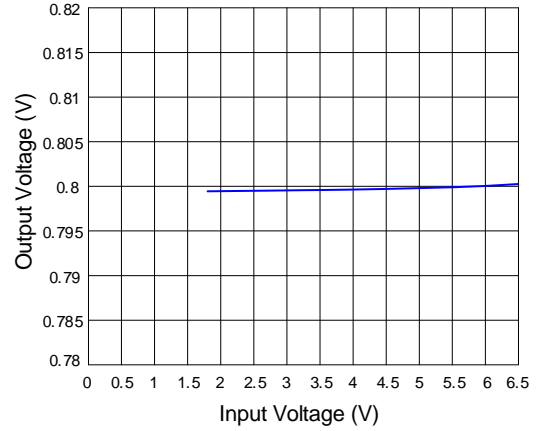

Load Regulation
(V_IN=1.8V, V_OUT=0.8V, FB tied to OUT)

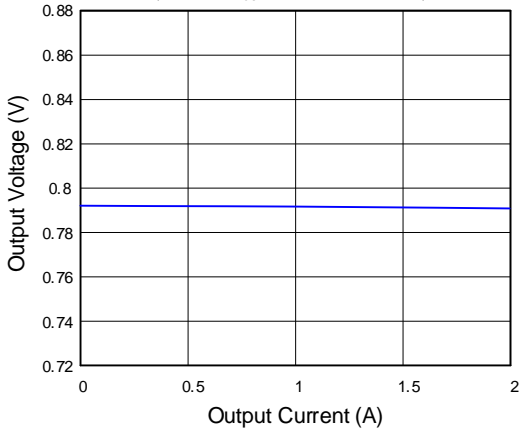

Dropout Voltage vs. Output Current
(FB tied to GND)

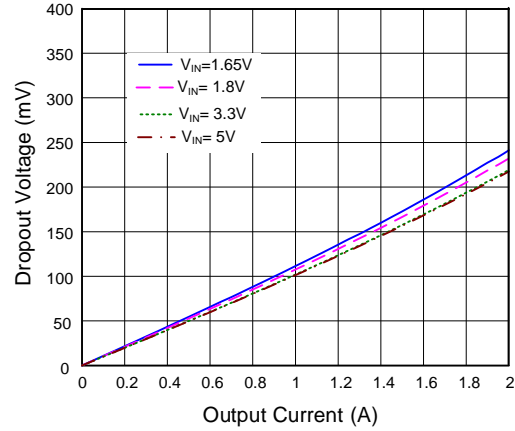

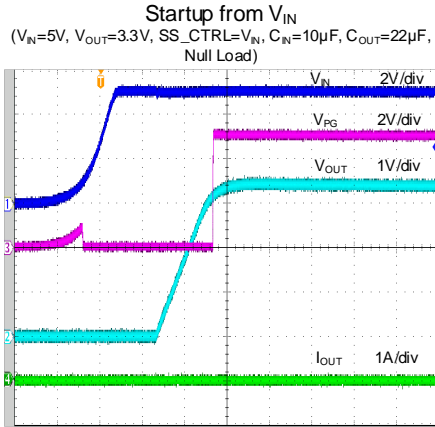
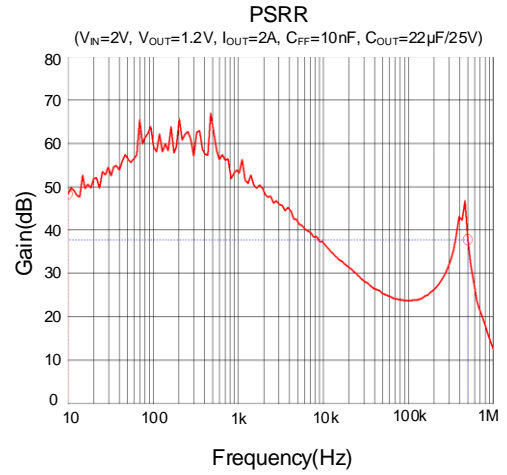
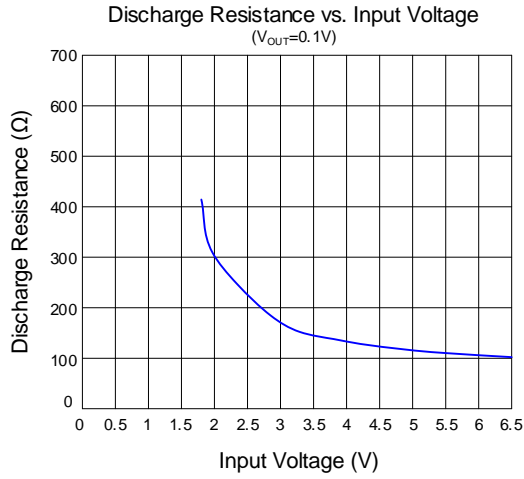

Time (40μs/div)

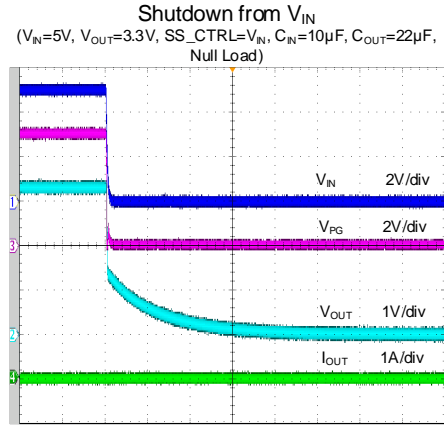

Time (1s/div)

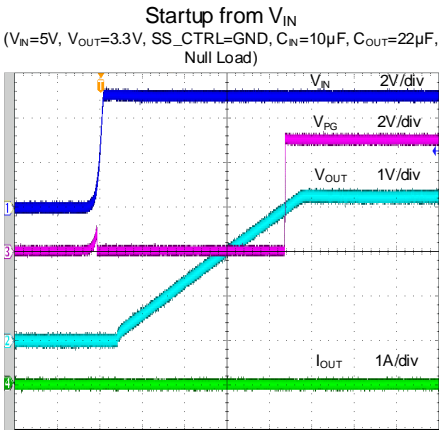

Time (200μs/div)

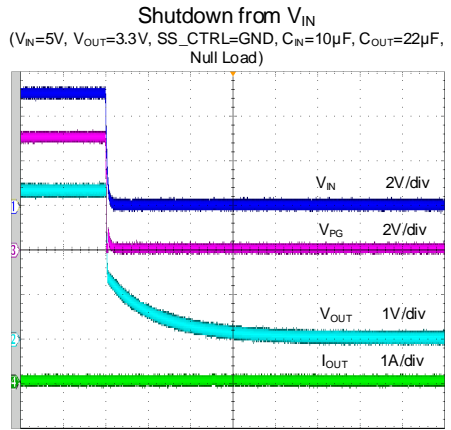

Time (1s/div)

Startup from V_{IN}
 ($V_{IN}=5V$, $V_{OUT}=3.3V$, $SS_CTRL=V_{IN}$, $C_{IN}=10\mu F$, $C_{OUT}=22\mu F$,
 $I_{OUT}=2A$)

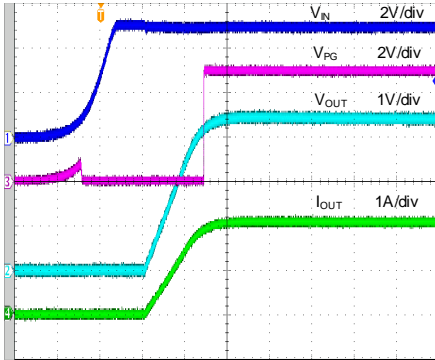

Time (40 μ s/div)

Shutdown from V_{IN}
 ($V_{IN}=5V$, $V_{OUT}=3.3V$, $SS_CTRL=V_{IN}$, $C_{IN}=10\mu F$, $C_{OUT}=22\mu F$,
 $I_{OUT}=2A$)

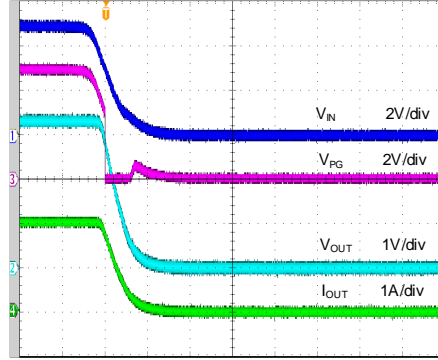

Time (100 μ s/div)

Startup from V_{IN}
 ($V_{IN}=5V$, $V_{OUT}=3.3V$, $SS_CTRL=GND$, $C_{IN}=10\mu F$, $C_{OUT}=22\mu F$,
 $I_{OUT}=2A$)

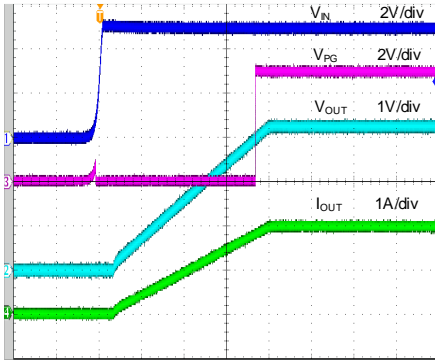

Time (200 μ s/div)

Shutdown from V_{IN}
 ($V_{IN}=5V$, $V_{OUT}=3.3V$, $SS_CTRL=GND$, $C_{IN}=10\mu F$, $C_{OUT}=22\mu F$,
 $I_{OUT}=2A$)

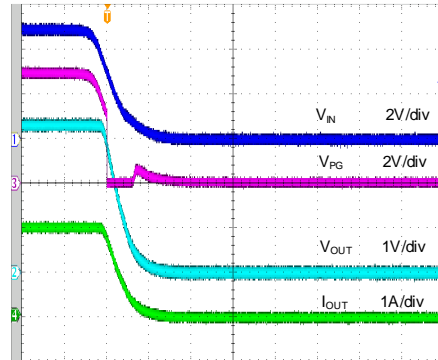

Time (100 μ s/div)

Startup from EN
 ($V_{IN}=5V$, $V_{OUT}=3.3V$, $SS_CTRL=V_{IN}$, $C_{IN}=10\mu F$, $C_{OUT}=22\mu F$,
 Null Load)

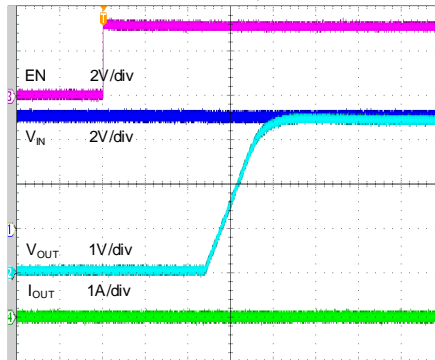

Time (40 μ s/div)

Shutdown from EN
 ($V_{IN}=5V$, $V_{OUT}=3.3V$, $SS_CTRL=V_{IN}$, $C_{IN}=10\mu F$, $C_{OUT}=22\mu F$,
 Null Load)

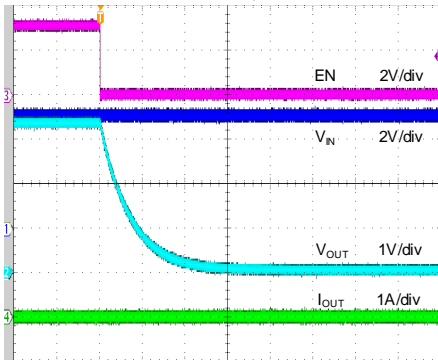

Time (4ms/div)

Startup from EN

($V_{IN}=5V$, $V_{OUT}=3.3V$, $SS_CTRL=GND$, $C_N=10\mu F$, $C_{OUT}=22\mu F$, Null Load)

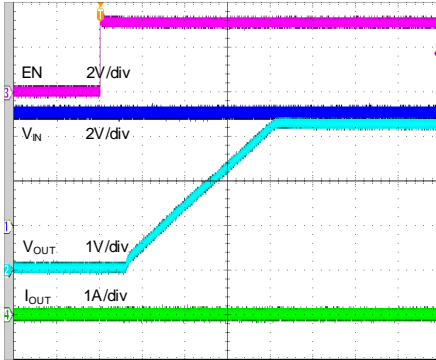

Time (200 μ s/div)

Shutdown from EN

($V_{IN}=5V$, $V_{OUT}=3.3V$, $SS_CTRL=GND$, $C_N=10\mu F$, $C_{OUT}=22\mu F$, Null Load)

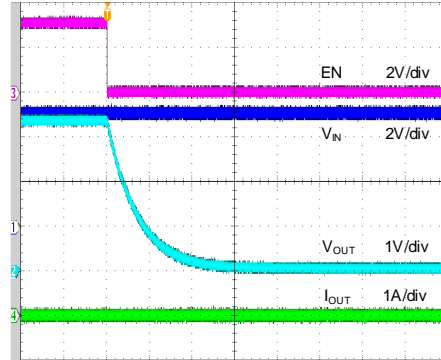

Time (4ms/div)

Startup from EN

($V_{IN}=5V$, $V_{OUT}=3.3V$, $SS_CTRL=V_{IN}$, $C_N=10\mu F$, $C_{OUT}=22\mu F$, $I_{OUT}=2A$)

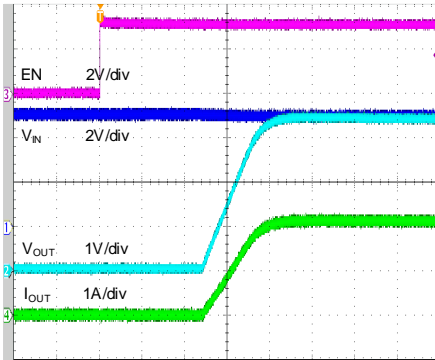

Time (40 μ s/div)

Shutdown from EN

($V_{IN}=5V$, $V_{OUT}=3.3V$, $SS_CTRL=V_{IN}$, $C_N=10\mu F$, $C_{OUT}=22\mu F$, $I_{OUT}=2A$)

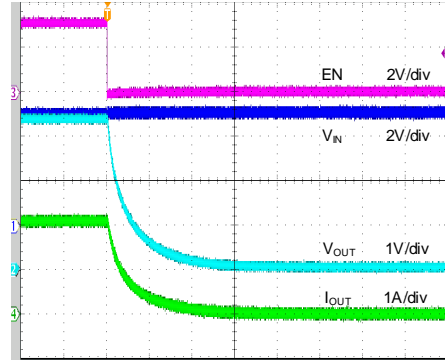

Time (40 μ s/div)

Startup from EN

($V_{IN}=5V$, $V_{OUT}=3.3V$, $SS_CTRL=GND$, $C_N=10\mu F$, $C_{OUT}=22\mu F$, $I_{OUT}=2A$)

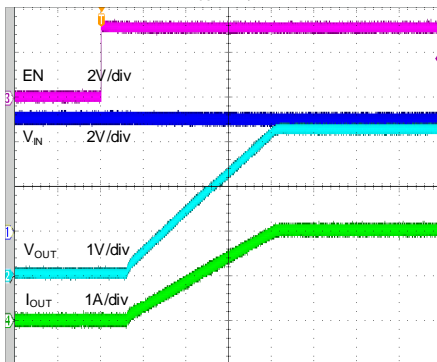

Time (200 μ s/div)

Shutdown from EN

($V_{IN}=5V$, $V_{OUT}=3.3V$, $SS_CTRL=GND$, $C_N=10\mu F$, $C_{OUT}=22\mu F$, $I_{OUT}=2A$)

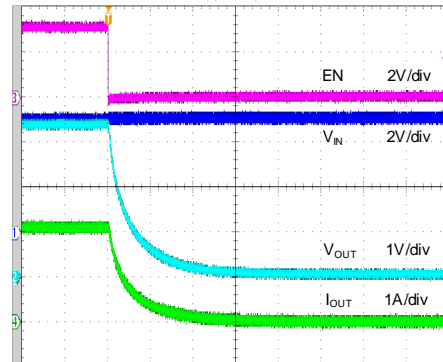

Time (40 μ s/div)

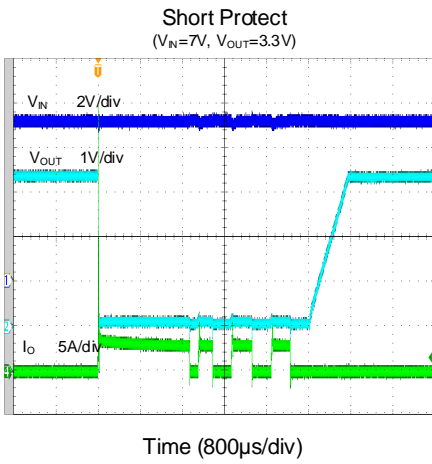
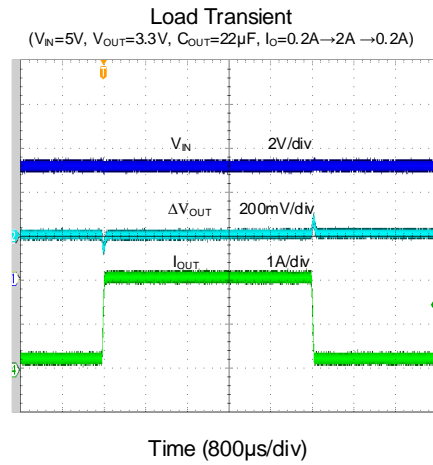
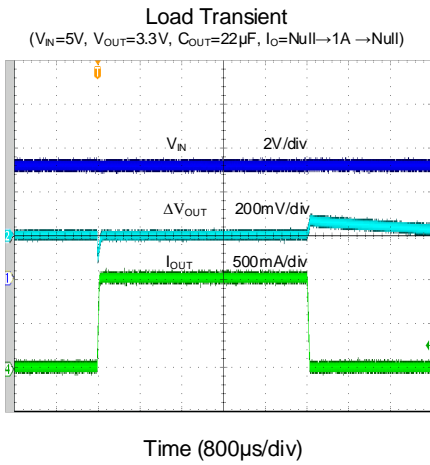

Operation

The SY6321B is a high-performance positive voltage regulator designed for use in applications which require very low input voltage and very low dropout voltage at up to 2A output. It operates with a V_{IN} as low as 1.8V, with output voltage programmable as low as 0.8V.

The SY6321B features ultra-low dropout, ideal for applications where V_{OUT} is very close to V_{IN} . Additionally, it has an enable pin to further reduce power dissipation while shut down. The device provides excellent regulation over variations in line, load, and temperature.

Applications Information

Input Capacitor C_{IN} :

To minimize the potential noise problem and improve power-supply rejection ratio (PSRR) and transient response, place a typical X5R or better grade ceramic capacitor close to the IN and GND pins. Care should be taken to minimize the loop area formed by C_{IN} , and IN/GND pins. In this case, a 10 μ F low ESR ceramic capacitor is recommended.

Output Capacitor C_{OUT} :

For stable operation over the full temperature range, a 22 μ F low-ESR ceramic capacitor is recommended. Use 22 μ F to reduce noise, improve load-transient response and PSRR.

Feedback Resistor Dividers R_3 and R_2 :

Choose R_3 and R_2 to program the proper output voltage. To minimize the power consumption under light loads, it is desirable to choose large resistance values for both R_3 and R_2 . A value of between 10k Ω and 1M Ω is highly recommended for both resistors. If V_{OUT} is 3.3V, $R_3=50k\Omega$ is chosen, then using following equation, R_2 can be calculated to be 16k Ω :

$$R_2 = \frac{0.8V}{V_{OUT} - 0.8V} R_3$$

Over Current Protection:

The device includes over current protection. The current limitation circuit regulates the output current to its limitation threshold to protect the IC from damage. Under over current condition, the power loss of the IC is relatively high. And that may trigger the thermal protection.

Power Good Function:

The SY6321B device provides an open-drain PG output that goes high when the output is within $\pm 10\%$ of REFOUT. PG is an open-drain output, a pull-up resistor with a value between 10 k Ω and 100 k Ω , placed

between PGOOD and a stable active supply voltage rail is required.

Soft Start Function:

Soft-start refers to the ramp-up characteristic of the output voltage during LDO turn-on after the EN and UVLO thresholds are exceeded. The noise-reduction capacitor ($C_{NR/SS}$) serves a dual purpose of both governing output noise reduction and programming the soft-start ramp during turn-on. Larger values for the noise-reduction capacitors decrease the noise but also result in a slower output turn-on ramp rate.

The SY6321B features an SS_CTRL pin. When the SS_CTRL pin is grounded, the charging current for the NR/SS pin is 8.5 μ A (typ); when this pin is connected to IN, the charging current for the NR/SS pin is increased to 135 μ A (typ). The higher current allows the use of a much larger noise-reduction capacitor and maintains a reasonable startup time.

t_{SS} is from 10% V_{OUT} to 90% V_{OUT} as recommended. Formula for Soft-start time calculation:

$$t_{SS} = (0.8 \times V_{REF} \times C_{NR/SS}) / I_{NR/SS}$$

Enable Protection:

The enable pin for the SY6321B is active high. The output voltage is enabled when the enable pin voltage is greater than $V_{EN(HI)}$ and disabled with the enable pin voltage is less than $V_{EN(LO)}$. If independent control of the output voltage is not needed, then connect the enable pin to the input.

Thermal Considerations:

The SY6321B can deliver a current of up to 2A over the full operating temperature range. However, the maximum output current must be derated at higher ambient temperature. With all possible conditions, the junction temperature must be within the range specified under operating conditions. Power dissipation can be calculated based on the output current and the voltage drop across regulator.

$$P_D = (V_{IN} - V_{OUT}) \times I_{OUT} + V_{IN} \times I_{GND}$$

The final operating junction temperature for any set of condition can be estimated by the following thermal equation:

$$P_{D(MAX)} = (T_{J(MAX)} - T_A) / \theta_{JA}$$

Where $T_{J(MAX)}$ is the maximum junction temperature of die (125 $^{\circ}$ C) and T_A is the maximum ambient temperature. The junction to ambient thermal resistance (θ_{JA}) footprint is 61 $^{\circ}$ C /W for DFN package.

Schematic

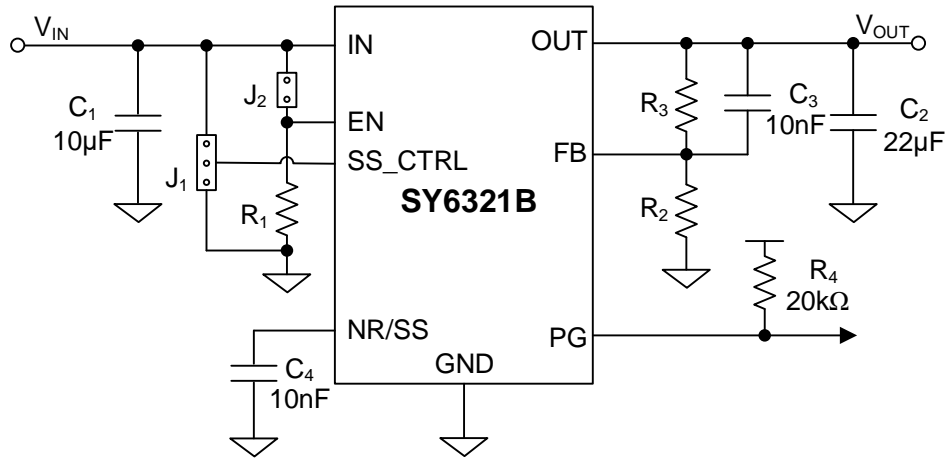

BOM List

Reference Designator	Description	Part Number	Manufacturer
C ₁	10µF/10V, ±10%, X5R, 0805	GRM21BR71A106K	Murata
C ₂	22µF/10V, ±10%, X5R, 1206	GRM31CR61A226M	Murata
C ₃	10nF/50V, ±10%, X7R, 0603	GCE188R71H103K	Murata
C ₄	10nF/50V, ±10%, X7R, 0603	GCE188R71H103K	Murata
R ₁	10kΩ, 1%, 0.1W, 0603	RC0603FR-0710KL	YAGEO
R ₂	16kΩ, 1%, 0.1W, 0603	RC0603FR-0716KL	YAGEO
R ₃	49.9kΩ, 1%, 0.1W, 0603	RC0603FR-0749K9L	YAGEO
R ₄	20kΩ, 1%, 0.1W, 0603	RC0603FR-0720KL	YAGEO
J ₁	Header, 2.54 mm, 3x1, Gold, SMT		Any
J ₂	Header, 2.54 mm, 2x1, Gold, SMT		Any

PCB Layout Guide

For best performance of the SY6321B, the following guidelines must be strictly followed:

- 1) Keep all Power traces (VIN / OUT / GND) as short and wide as possible and use at least 2-ounce copper for all Power traces.
- 2) Place a ground plane under all circuitry to lower both resistance and inductance and improve DC and transient performance.
- 3) Input and output capacitors should be placed closed to the SY6321B and connected to ground plane to reduce noise coupling.

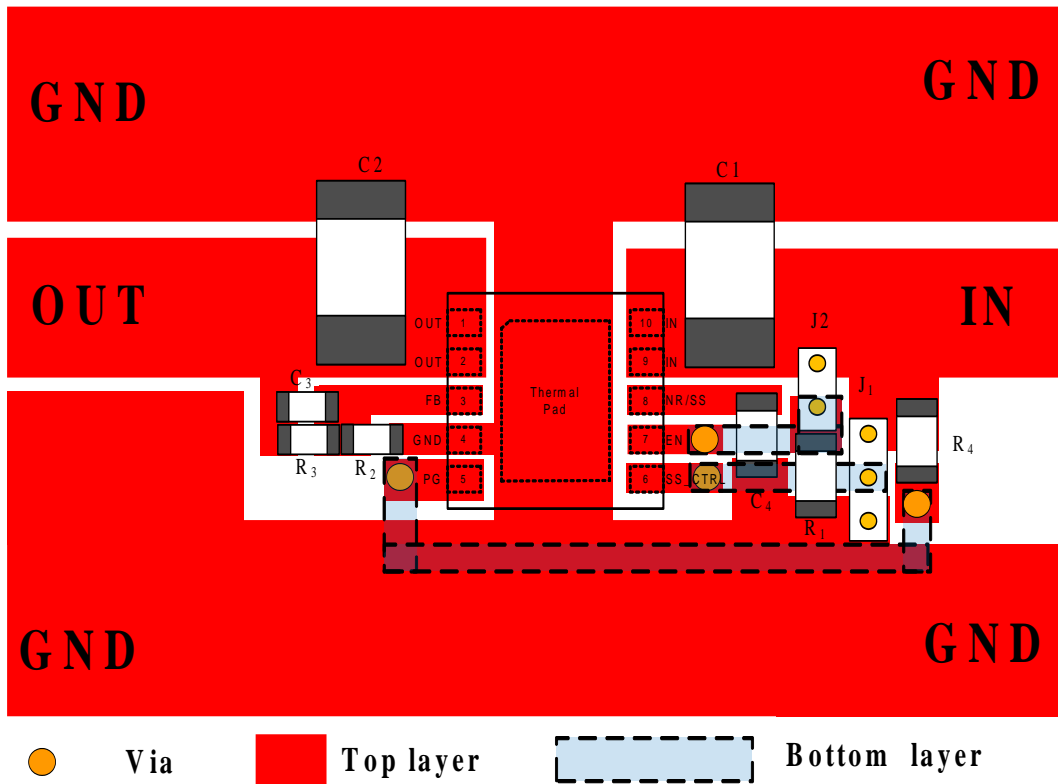
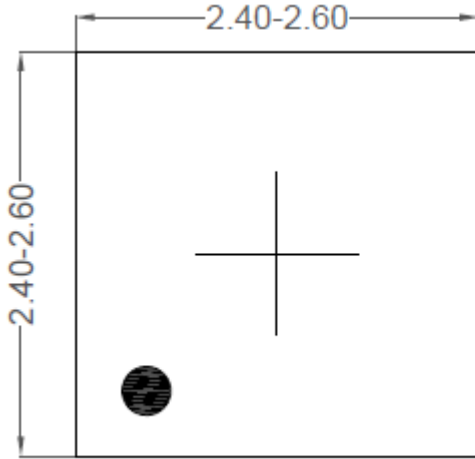
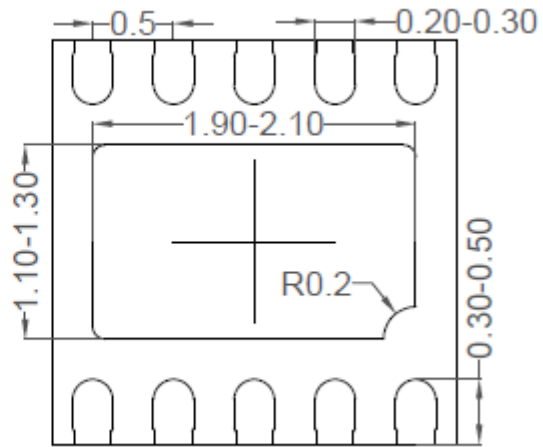

Figure3. PCB Layout Suggestion

DFN2.5×2.5-10 Package Outline Drawing



Top View



Bottom View

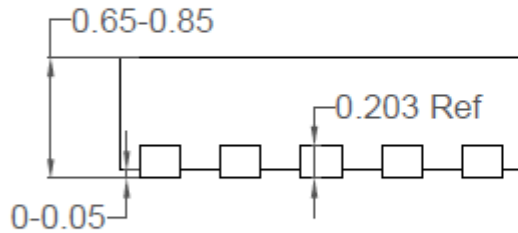

Front View

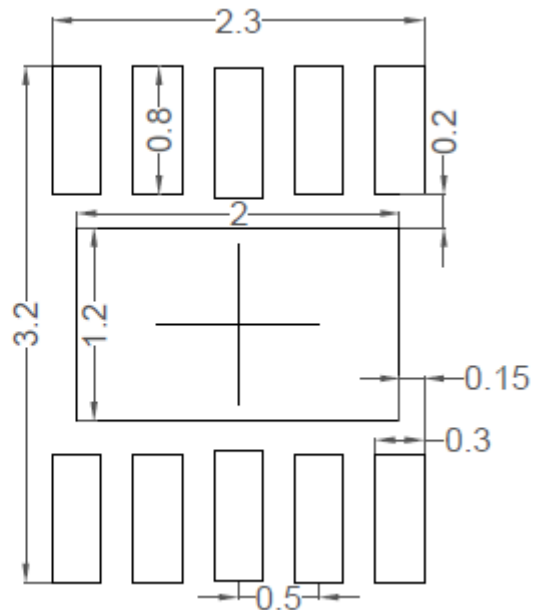

Recommended PCB Layout

Notes: 1, All dimension in millimeter and exclude mold flash & metal burr;
 2, center line refers chip body center.

Taping & Reel Specification

1. DFN2.5×2.5 taping orientation

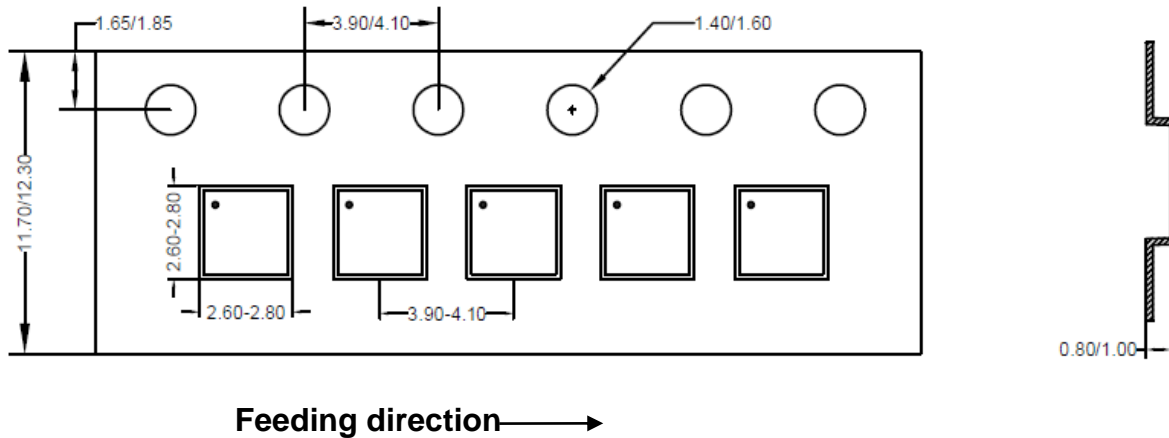

2. Carrier Tape & Reel specification for packages

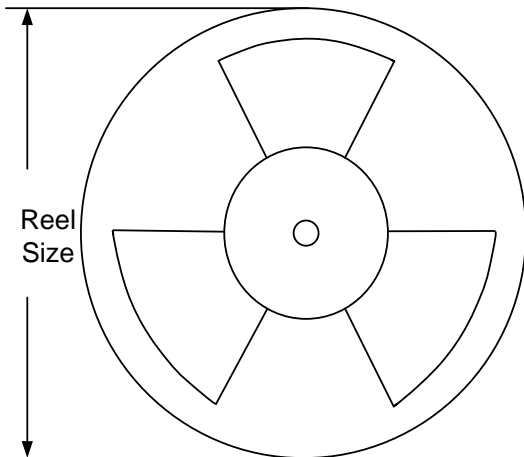

Package types	Tape width (mm)	Pocket pitch(mm)	Reel size (Inch)	Trailer length(mm)	Leader length (mm)	Qty per reel
DFN2.5×2.5-10	12	4	7"	400	160	3000

3. Others: NA



Revision History

The revision history provided is for informational purpose only and is believed to be accurate, however, not warranted. Please make sure that you have the latest revision.

Date	Revision	Change
Dec.06, 2023	Revision 1.0	Initial Release

IMPORTANT NOTICE

1. **Right to make changes.** Silergy and its subsidiaries (hereafter Silergy) reserve the right to change any information published in this document, including but not limited to circuitry, specification and/or product design, manufacturing or descriptions, at any time and without notice. This document supersedes and replaces all information supplied prior to the publication hereof. Buyers should obtain the latest relevant information before placing orders and should verify that such information is current and complete. All semiconductor products are sold subject to Silergy's standard terms and conditions of sale.
2. **Applications.** Application examples that are described herein for any of these products are for illustrative purposes only. Silergy makes no representation or warranty that such applications will be suitable for the specified use without further testing or modification. Buyers are responsible for the design and operation of their applications and products using Silergy products. Silergy or its subsidiaries assume no liability for any application assistance or designs of customer products. It is customer's sole responsibility to determine whether the Silergy product is suitable and fit for the customer's applications and products planned. To minimize the risks associated with customer's products and applications, customer should provide adequate design and operating safeguards. Customer represents and agrees that it has all the necessary expertise to create and implement safeguards which anticipate dangerous consequences of failures, monitor failures and their consequences, lessen the likelihood of failures that might cause harm and take appropriate remedial actions. Silergy assumes no liability related to any default, damage, costs or problem in the customer's applications or products, or the application or use by customer's third-party buyers. Customer will fully indemnify Silergy, its subsidiaries, and their representatives against any damages arising out of the use of any Silergy components in safety-critical applications. It is also buyers' sole responsibility to warrant and guarantee that any intellectual property rights of a third party are not infringed upon when integrating Silergy products into any application. Silergy assumes no responsibility for any said applications or for any use of any circuitry other than circuitry entirely embodied in a Silergy product.
3. **Limited warranty and liability.** Information furnished by Silergy in this document is believed to be accurate and reliable. However, Silergy makes no representation or warranty, expressed or implied, as to the accuracy or completeness of such information and shall have no liability for the consequences of use of such information. In no event shall Silergy be liable for any indirect, incidental, punitive, special or consequential damages, including but not limited to lost profits, lost savings, business interruption, costs related to the removal or replacement of any products or rework charges, whether or not such damages are based on tort or negligence, warranty, breach of contract or any other legal theory. Notwithstanding any damages that customer might incur for any reason whatsoever, Silergy' aggregate and cumulative liability towards customer for the products described herein shall be limited in accordance with the Standard Terms and Conditions of Sale of Silergy.
4. **Suitability for use.** Customer acknowledges and agrees that it is solely responsible for compliance with all legal, regulatory and safety-related requirements concerning its products, and any use of Silergy components in its applications, notwithstanding any applications-related information or support that may be provided by Silergy. Silergy products are not designed, authorized or warranted to be suitable for use in life support, life-critical or safety-critical systems or equipment, nor in applications where failure or malfunction of a Silergy product can reasonably be expected to result in personal injury, death or severe property or environmental damage. Silergy assumes no liability for inclusion and/or use of Silergy products in such equipment or applications and therefore such inclusion and/or use is at the customer's own risk.
5. **Terms and conditions of commercial sale.** Silergy products are sold subject to the standard terms and conditions of commercial sale, as published at <http://www.silergy.com/stdterms>, unless otherwise agreed in a valid written individual agreement specifically agreed to in writing by an authorized officer of Silergy. In case an individual agreement is concluded only the terms and conditions of the respective agreement shall apply. Silergy hereby expressly objects to and denies the application of any customer's general terms and conditions with regard to the purchase of Silergy products by the customer.
6. **No offer to sell or license.** Nothing in this document may be interpreted or construed as an offer to sell products that is open for acceptance or the grant, conveyance or implication of any license under any copyrights, patents or other industrial or intellectual property rights. Silergy makes no representation or warranty that any license, either express or implied, is granted under any patent right, copyright, mask work right, or other intellectual property right. Information published by Silergy regarding third-party products or services does not constitute a license to use such products or services or a warranty or endorsement thereof. Use of such information may require a license from a third party under the patents or other intellectual property of the third party, or a license from Silergy under the patents or other intellectual property of Silergy.

For more information, please visit: www.silergy.com

©2023 Silergy Corp.

All Rights Reserved.